

CATALOG # 107

# Aluminum Castings

Call Toll Free : 800.527.1318 • Fax 972.557.4727



**Alloy Casting**

**ALUMINUM CASTINGS**

3900 S. Peachtree Road • Mesquite, Tx 75180-27724

[www.alloynet.com](http://www.alloynet.com)









## ALUMINUM CASTINGS

Toll Free (800) 527-1318

(972) 286-2368

Fax: (972) 557-4727

Section:

## Table of Contents

Acorn Friezes . . . . .	18	Flanges : Square Hole . . . . .	75, 75A, . . . . . 75B,75C,75D,75E,75F,76	Passion Flower . . . . .	31,32
Allomet/Allo marine . . . . .	140	Flanges: Colonial . . . . .	79	Picket Castings (Holes in Lugs) . . . . .	13
Alloy Selection appendix, 10,11,12		Flanges: Round Hole . . . . .	74	Picket Castings 1/2" . . . . .	7,8,9,10,13, . . . . . 145,149
Aluminum Hardware . . . . .	98,105,106,107,110	Flanges: Square Hole 1" . . . . .	75A	Picket Castings 5/8", 3/4", 1") . . . . .	12
Animals, Fish . . . . .	146	Flanges: Square Hole 1/2" 5/8" 3/4" . . . . .	75	Pineapple. . . . .	65
Anthemion Crown Castings 35, 36, . . . . .	116	Flanges: Square Hole 1 1/2" . . . . .	75C, . . . . . 75D	Plaques . . . . .	64, 65,68,104,105
Appendix. . . . .	19 pages	Flanges: Square Hole 1 1/4" . . . . .	75B	Plaques: Eagle Castings . . . . .	66
Assemblies . . . . .	93, 94	Flanges: Square Hole 2 1/2", 3"75E		Plaques: Western . . . . .	67
Assemblies: Flower Pot . . . . .	92	Flanges: Square Hole 2" . . . . .	75D	Plates, Floor . . . . .	98
Assemblies: Weathervane . . . . .	94	Flanges: Square Hole 4", 5 1/2",6" . . . . .	75F	Pontalba . . . . .	38,39
Autocad . . . . .	136,162	Fleur de Lis . . . . .	59,63,63A	Post Caps and Hand Rails . . . . .	80,107
Ball Caps . . . . .	86, 108, 158	Floor Plates . . . . .	98	Powder Coating . . . . .	appendix, 13,14,15,16,17,18,19
Ball Finials . . . . .	87, 87A, 108	Flower Pots . . . . .	92	Pyramid Caps . . . . .	80,107,158
Balusters 60,110,111,112,113,115,11 . . . . .	6,124A,124B, 155,161	Forgings . . . . .	110,111,115	Rail Shoes . . . . .	75G, 75H
Balusters and Column Castings . . . . .	61	Foundation Vents. . . . .	145	Railing-42". . . . .	160
Bamboo . . . . .	132	Furniture Pieces . . . . .	91	Restoration. . . . .	appendix,7,8,9
Banana Leaf . . . . .	133	Gate Designs . . . . .	137	Rings 40,41,42,43,118,119,120,156	
Baskets . . . . .	105	Grapes . . . . .	28,29,30	Roman . . . . .	55,150,151
Bell . . . . .	93	Greek Key Castings . . . . .	33,34, 145	Roof Cresting and Marquees . . . . .	89
Bell Flowers . . . . .	51	Guardian Style Castings 7,10,11,160		Rope . . . . .	112,116,125
Belly Pickets . . . . .	112,113	Hand Rail Brackets . . . . .	80	Roses . . . . .	25,26,27,144
Benches and Bench Ends . . . . .	95	Hardware, Aluminum 98,105,106, . . . . .	107,110	Rosettes . . . . .	62,63,63A,63B,144
Bendable Castings . . . . .	152	Heavy Duty Castings . . . . .	58, 59	S Scrolls . . . . .	109
Big Oak Castings . . . . .	21	Hinge Straps Decorative . . . . .	69	Sailboats . . . . .	104
Big Tex. . . . .	135	Hinges . . . . .	98,106,107,110	Sales Tax Certificate (Texas only). . . . .	142
Birds of Paradise . . . . .	23,24	Horses . . . . .	131	Scroll Freizes . . . . .	16,17,112
Boating Designs . . . . .	154	Index . . . . .	2,3, 3A, 3B	Scroll Panels 48,51,56,109,121,143	
Boot Jack. . . . .	146	Index, Old Numbers . . . . .	4	Sea Horses . . . . .	104,134
C Scrolls . . . . .	7,11A,109	Ivy . . . . .	47	Sea Shells . . . . .	63B,64,132,155
Capssee Ball Caps or Pyramid Caps		Lamb under Willow . . . . .	59	Security Door: Acorn Friezes . . . . .	18
Catalog Number Vs page number2,3		Late Additions . . . . .	99	Security Door: Panel Castings 14,15	
Channel Shoes . . . . .	751	Lattice Collars . . . . .	165	Security Door: Scroll Friezes 16,17	
Chinese . . . . .	47	Leaves 107,108,109, 147, 166, 167		Shelf Brackets and Decorative . . . . .	90
Circle Castings . . . . .	43	Letters . . . . .	71	Shoes 75, 75A, 75B,75C,75D, 75E, . . . . . 75F,76	
Circles and Ovals 40,41,42,43,118, . . . . .	119,120,156	Lion Head . . . . .	65	Sign . . . . .	141
Circumscribed Circles . . . . .	163	Lockboxes, Aluminum .96,97,106		Spear Points Flat Bases . . . . .	129
Collars . . . . .	85,105, 164	Magnolia . . . . .	50	Spear Points-Drive In . . . . .	81,82,108, . . . . . 128B,129
Collars-Round 85,105,127,156,163, . . . . .	164,165	Mail Box Pieces . . . . .	61,68,141,153	Spear Points-Slip Over 83,84,128, . . . . .	128A,148
Collars-Square 85,126,145,156,158, 159,163,164,165		Management Comments . . . . .	6	Square in Square . . . . .	45
Colonial Flanges . . . . .	79	Maps UPS . . . . .	142	Stars . . . . .	70, 130,156
Column . . . . .	61,114	Maps to Alloy . . . . .	142	Sundials . . . . .	93
Converting Old Cat # to new # . . . . .	4	Marine Grade . . . . .	appendix, . . . . . 16,17,18,19,140	Table of Contents . . . . .	1, 1A
Credit Application . . . . .	103	Marquee . . . . .	89	Tassels . . . . .	148
Crosses . . . . .	147	Metal Selection appendix, 10,11,12		Technical Definitions . . . . .	100,101
Custom Casting appendix, . . . . .	5,1,2,3,4,5,6	Mixed Castngs46,47,48,49,50,51,52, . . . . .	53,54,55,56,57	Terms and Conditions . . . . .	102
Decorative . . . . .	90	Modern . . . . .	44,45,114,144	Traditional Oak Castings . . . . .	19,20
Decorative Hinge Straps . . . . .	69	Morning Glory . . . . .	49	Trivets . . . . .	88
Definitions . . . . .	100,101	New Additions 143,144,145,146,14 . . . . .	7,148,149	Tulip . . . . .	47
Diptych Designs . . . . .	157	Numbers . . . . .	72,73	UPS map . . . . .	142
Dolphins . . . . .	43,104,134	Oak Castings . . . . .	19,20,21,22	Vents, Foundation . . . . .	145
Door Castings . . . . .	14,15,16,17,18	Oak Freizes . . . . .	18	Victorian . . . . .	37,99,143
Eagles . . . . .	43,66,116	Ovals and Circles . . . . .	40,41,42,43	Weathervanes . . . . .	94
FabCad . . . . .	136,162	Palm Trees . . . . .	64,133,155	Wedding . . . . .	46
Finials . . . . .	77,78,108	Palms. . . . .	157	Western . . . . .	67,130
Fish. . . . .	146			Windvane . . . . .	94
				X Collars . . . . .	165
				X Panels . . . . .	57,148



Section:

Toll Free (800) 527-1318

(972) 286-2368

Fax: (972) 557-4727

Index



ALUMINUM CASTINGS

Part# . . . .Page#	Part# . . . .Page#	Part# . . . .Page#	Part# . . . .Page#	Part# . . . .Page#	Part# . . . .Page#	Part# . . . .Page#
#0001. . . . .7	#0134 . . . 74,79	#0246. . . . .14	#0482. . . . .112	#0703. . . . .149	#0836. . . . .40	#0985. . . . .55
#0002. . . . .7	#0135 . . . 74,79	#0247. . . . .14	#0483. . . . .112	#0705. . . . .49	#0838. . . . .44	#0990. . . . .61
#0003. . . . .7	#0137. . . . 75E	#0248. . . . 15,23	#0495. . . . 75C	#0706. . . . .49	#0839. . . . .42	#0993. . . . 105
#0004. . . . .7	#0138. . . . 75F	#0249. . . . 15,23	#0498. . . . 75C	#0707. . . . .41	#0840. . . . .42	#0997. . 122, 141
#0005. . . . .7	#0140. . . . .85	#0250. . . . .21	#0500. . . . .50	#0710. . . . .149	#0841. . . . .42	#0998. . . 61, 141
#0006. . . . .7	#0141. . . . .85	#0251. . . . .21	#0501. . . . .50	#0711. . . 70, 156	#0843. . . . .44	#1001. . . . .12
#0007. . . . .7	#0142. . . . 85, 127	#0252. . . . .21	#0502. . . . .50	#0712. . . . .156	#0850. . . . .46	#1002. . . . .12
#0008. . . . .7	#0143. . . . .85	#0253. . . . .21	#0503. . . . .50	#0712. . . . .70	#0851. . . . .46	#1003. . . . .13
#0009. . . . .7	#0144. . . . 127	#0256. . . . .21	#0510. . . . .51	#0713. . . 70, 156	#0852. . . . .52	#1010. . . . 143
#0010. . . . .8	#0145. . . . 127	#0264. . . . .22	#0520. . . . .51	#0714. . . 70, 156	#0855. . . . .41	#1011. . . . 143
#0011. . . . .8	#0146. . . . 127	#0265. . . . .22	#0526. . . . .38	#0719. . . . 125	#0856. . . . .46	#1020. . . . 15,23
#0012. . . . 8,19	#0148. . . . 127	#0270. . . . .22	#0527. . . . .38	#0721. . . . 130	#0858. . . . .41	#1022. . . . .17
#0017. . . . .8	#0150. . 60, 124A	#0271. . . . .22	#0530. . . 44, 143	#0722. . . 34, 130	#0860. . . . .38	#1027. . . . .18
#0018. . . . .8	#0151. . . . .60	#0280. . . . .22	#0531. . . . 143	#0723. . . 33, 130	#0861. . . . .38	#1033. . . . .98
#0019. . . . .8	#0152. . . . .60	#0282. . . . .22	#0532. . . . 143	#0724. . . . 130	#0862. . . . .39	#1044. . . . .98
#0020. . . . .9	#0154. . . . 125	#0283. . . . .22	#0534. . . . .40	#0750. . . . .34	#0863. . . . .38	#1066. . . . .98
#0021. . . . 8,28	#0156. . . . 125	#0285. . . . .22	#0535. . . . .40	#0751. . . . .33	#0864. . . . .38	#1070 37, 58, 162
#0022. . . . 8,38	#0158. . . . 112	#0298. . . . .29	#0536. . . . .41	#0752. . . . .34	#0865. . . 15,38	#1072 . . . 37,58
#0023. . . . 8,26	#0159 . . . . 112	#0299. . . . .29	#0537. . . . .41	#0755. . . . .33	#0866. . . . 121	#1084. . . . 107
#0024. . . . 9,47	#0160 . . . . 114	#0300. . . . .29	#0538. . . . .17	#0756. . . . .33	#0868. . . . .38	#1085. . . . 107
#0025. . . . .9	#0161. . . . 112	#0301. . . . .29	#0539. . . . .18	#0757. . . . .33	#0869. . . . 149	#1086. . . . 106
#0026. . . . .9	#0162. . . . 124	#0302. . . . .28	#0540 SERIES .	#0758. . . . 145	#0874. . . . .57	#1087. . . . 106
#0028. . . . 9,44	#0163. . . . 122	#0304. . . . .28	71,72	#0759. . . . .34	#0875. . . . .51	#1088. . . 68, 153
#0029. . . . .9	#0164. . . . .85	#0306. . . . .28	#0541. . . . 143	#0760. . . . .33	#0876. . . . .51	#1090. . . . 106
#0030. . . . .85	#0165. . . . .85	#0307. . . . .28	#0544 . . . 71,72	#0761. . . . .33	#0877. . . . .57	#1091. . . . .98
#0031. . . . 9,24	#0166. . . . 122	#0308. . . . .28	#0545 SERIES .	#0762. . . . .33	#0878. . . . .57	#1092. . . . .98
#0032. . . . 9,10	#0167. . . 124B	#0309. . . . .29	71,72	#0763. . . . .33	#0879. . . . .57	#1093. . . . .98
#0033. . . . 11A	#0168. . . . 123	#0310. . . . .29	#0548 SERIES .	#0764. . . . .33	#0880. . . . .57	#1094. . . . 106
#0034. . . . 105	#0169. . . . 124	#0312. . . . .29	71,72	#0765. . . . .33	#0881. . . . .41	#1095. . . . .98
#0035. . . . 105	#0170. . . . .68	#0314. . . . .30	#0549 SERIES .	#0766. . . . .33	#0885. . . . .37	#1098. . . . .98
#0036. . . . .67	#0171. . . . .68	#0315. . . . .28	71,72	#0767. . . . .34	#0886. . . 37,58	#1099. . . . .98
#0061. . . . .66	#0172. . . . .68	#0316. . . . .28	#0550. . . . .48	#0768. . . . .53	#0887. . . . .54	#1100. . . . 105
#0062. . . . .66	#0173. . . . .68	#0317. . . . 147	#0552. . . . .48	#0769. . . 53,58	#0888. . . . .35	#1101. . . . .32
#0063. . . . .66	#0178. . . . 124	#0320. . . . .28	#0553. . . . .48	#0770. . . . 122	#0889. . . . .36	#1102. . . . .32
#0064. . . . .66	#0180. . . . 9,44	#0333. . . . 11A	#0555. . . . .38	#0775. . . . .37	#0890. . . . .35	#1120. . . . 105
#0068. . . . .91	#0181. . 122,131	#0358. . . . 75J	#0557. . . . .30	#0776. . . . .9	#0891. . . . .36	#1122. . . . 107
#0069. . . . .91	#0191. . . . .90	#0400. . . . .23	#0560 SERIES71	#0790. . . . .37	#0892. . . . .65	#1123. . . . 107
#0070. . . . .91	#0200. . . . .19	#0401. . . . .23	#0562. . . 56, 141	#0800. . . . .48	#0894. . . . .51	#1125. . . . 105
#0071. . . . .90	#0201. . . . .20	#0402. . . . .24	#0563. . . . .56	#0801. . . . .48	#0896. . . . .36	#1127. . . . 107
#0072. . . . .90	#0203. . . . .20	#0403. . . . .24	#0564. . . . .71	#0802. . . . .45	#0899. . . . .35	#1131. . . . 110
#0073. . . . .90	#0204. . . . .20	#0404. . . . .23	#0590. . . . .90	#0803. . . . .45	#0900. . . . .54	#1132. . . . 106
#0074. . . . .91	#0206. . . . .19	#0405. . . . .24	#0591. . . 56, 141	#0804. . . . .48	#0901. . . . .54	#1134. . . . 110
#0075. . . . .91	#0207. . . . .20	#0406. . . . .24	#0592. . . . .56	#0805. . . . .52	#0906. . . . 135	#1138. . . . 105
#0081. . . . .94	#0208. . . . .20	#0407. . . . .24	#0600. . . . .25	#0806. . . . .45	#0908. . . . .53	#1139. . . . 105
#0082. . . 68, 131	#0209. . . . .20	#0408. . . . .24	#0601. . . . .27	#0807. . . . .46	#0909. . . 53,58	#1141. . . . 112
#0083. . . . .92	#0210. . . . .20	#0409. . . . .24	#0602. . . . .27	#0808. . . . .41	#0920. . . . .37	#1143. . . . 116
#0090. . . . .92	#0211. . . . .21	#0410. . . . .24	#0603. . . . .26	#0809. . . . .44	#0922. . . . 145	#1172. . . . 110
#0091. . . . 138	#0212. . . . .20	#0415. . . . .24	#0610 . . . . 25	#0810. . . . .44	#0927. . . . 151	#1180. . . . 13
#0092. . . . 138	#0215. . . . .20	#0416. . . . .24	#0611. . . . .25	#0811. . . . .41	#093055, 117,151	#1182. . . . .96
#0100. . . . .31	#0216. . . . .20	#0417. . . . 75I	#0612. . . . 145	#0812. . . . .52	#0931. . . 55, 150	#1183. . . . .96
#0101. . . . .32	#0217. . . . 147	#0418. . . . 75I	#0616. . . . 144	#0813. . . . .46	#0932. . . . 150	#1184. . . . .96
#0102. . . . .32	#0220. . . . .11	#0419. . . . 75I	#0619. . . . 25	#0814. . . 56,58	#0933. . . . .37	#1188. . . . .96
#0104. . . . .32	#0221. . . 11,16	#0422. . . 11,13	#0620. . . . .25	#0815. . . . .46	#093455, 151, 152	#1191. . . . 106
#0105. . . . .31	#0223. . . . .9	#0426. . . 13,18	#0621. . . . .25	#0816. . . . .47	#0936. . . . 150	#1197. . . . 106
#0107. . . . .31	#0224. . . . .10	#0428. . . . 75I	#0622. . . . .25	#0817. . . . .47	#0937. 112, 151,	#1240. . . . 154
#0108. . . . .32	#0225. . . . .10	#0431. . . . .16	#0623. . . . .26	#0818. . . . .53	162	#1241. . . . 154
#0109. . . . .32	#0226. . . . .10	#0432. . . . .17	#0624. . . . .27	#0819. . . . .56	#0938. 112, 151,	#1243. . . . 13
#0110. . . . .92	#0227. . . . .10	#0433. . . . .17	#0625. . . . .26	#0820. . . . .54	152	#1244. . . . 126
#0111. . . . .92	#0231. . . . .16	#0435. . . . .17	#0626. . . . .26	#0821. . . . .44	#0939. 117, 133,	#1245. . . . 126
#0112. . . . .92	#0232. . . . .16	#0436. . . . .17	#0627. . . . .27	#0822. . . . .37	150, 162	#1246. . . . 126
#0113. . . . .92	#0233. . . . .16	#0437. . . . .16	#0628. . . . .26	#0823. . . . .52	#0940. . . . .52	#1248. . . . 126
#0114. . . . .92	#0234. . . . .16	#0438. . . . .17	#0629. . . . .26	#0824. . . . .37	#0941. . . . .121	#1251. . . . .21
#0115. . . . .92	#0235. . . . .18	#0439. . . . .16	#0630. . . . .47	#0825. . . . .38	#0950. . . . .54	#1252. . . . .21
#0116. . . . .92	#0236. . . . .18	#0445. . . . .18	#0631. . . . .26	#0826. . . . .59	#0951. . . . .54	#1271. . 108, 167
#0120. . . . .47	#0237. . . . .16	#0446. . . . .17	#0633. . . . 11A	#0827. . . . .47	#0955. . . . .54	#1272. . 108, 167
#0121. . . . .47	#0238. . . . .16	#0448. . . 15,23	#0634. . . . .83	#0828. . . . .56	#0956. . . . .51	#1274. . . . 108
#0122. . . . .47	#0239. . . . .18	#0452. . . . .89	#0640 . . . 15,50	#0830. . . . .35	#0957. . . . .55	#1275. . . . 108
#0125. . . . .52	#0241. . . 14,19	#0454. . . . .89	#0641 . . . . 50	#0831. . . . .35	#0960. . . . .35	#1276. . 108, 167
#0130. . . . .80	#0242. . . 14,31	#0455. . . . .18	#0650. . . . .51	#0832. . . . .36	#0961. . . . .35	#1278. . . . 108
#0131. . . . .80	#0243. . . 14,19	#0456. . . . .16	#0651 . . . . 51	#0833. . . . .40	#0970. . . . .55	#1283. . . . .96
#0132. . . . .77	#0244. . . 14,22	#0463. . . . .18	#0680 SERIES73	#0834. . . . .45	#0981. . . . .50	#1284. . . . .96
#0133. . . . .77	#0245. . . 14,19	#0464. . . . .18	#0701. . . . .49	#0835. . . . .89	#0983. . . . .37	#1286. . . . .96





Toll Free (800) 527-1318

(972) 286-2368

Fax: (972) 557-4727

Section:

Index

**ALUMINUM CASTINGS**

Part# . . . .Page#	Part# . . . .Page#	Part# . . . .Page#	Part# . . . .Page#	Part# . . . .Page#	Part# . . . .Page#	Part# . . . .Page#
#1288. . . . 96	#1761. . . . 108	#2094. . . . 153	#2684. . . . 115	#3530. . . . 141	#4432. . . . 120	#7121. . . . 42
#1297. . . . 106	#1762. . . . 108	#2105. . . . 31	#2685. . . . 115	#3531. . . . 141	#4434. . . . 131	#7121. . . . 156
#1300. . . 28, 162	#1765. . . . 33	#2111. . . . 157	#2686. . . . 113	#3702. . . . 64	#4439. . . . 153	#7122. . . . 156
#1303. . . . 28	#1770. . . 124A	#2112. . . . 157	#2687. . . . 115	#3702-03 SET 64	#4440. . . . 143	#7130. . . 40, 156
#1331. . . . 11A	#1771. . . 124A	#2120. . . . 149	#2688. . . . 115	#3704. . . . 64	#4446. . . . 122	#7134. . . . 156
#1333. . . . 11A	#1772. . . 124A	#2137. . . . 156	#2689. . . . 115	#3705-06 SET 64	#4449. . . . 144	#7137. . . . 156
#1340. . . . 105	#1800. . . . 121	#2140. . . . 159	#2691. . . . 115	#3707-08 SET 64	#4450. . . . 143	#714040, 119, 156
#1341. . . . 110	#1802. . . . 45	#2143. . . . 159	#2693. . . . 112	#3709. . . . 64	#4452. . . . 131	#7144. . . 40, 156
#1342. . . . 110	#1803. . . 48, 141	#2161 122, 124B,	#2694. . . . 113	#3711-12 SET64	#4453. . . . 120	#7146. . . . 156
#1346. . . . 116	#1804. . . . 121	155	#2695. . . . 115	#3713. . . . 69	#4454. . . . 146	#7147. . . . 156
#1347. . . . 110	#1807. . . . 46	#2162 124B, 155	#2696. . . . 115	#3714. . . . 69	#4456. . . . 104	#7150. . . . 156
#1348. . . . 110	#1811. . . . 41	#2191. . . 124B	#2703. . . . 109	#3715. . . . 69	#4457. . . . 130	#7152. . . 40, 156
#1349. . . . 110	#1812. . . . 52	#2192. . . 124B	#2704. . . . 109	#3716. . . . 69	#4460. . . . 133	#7153. . . . 156
#1380. . . . 97	#1814. . . . 46	#2193. . . 124B	#2705. . . . 109	#3717. . . . 69	#4463. . . . 104	#7157. . . 40, 156
#1385. . . . 97	#1818. . . . 53	#2201. . . . 19	#2709. . 11A, 109	#3718. . . . 69	#4465. . . . 133	#7170. . . . 156
#1388. . . . 97	#1822. . . . 59	#2222. . . 10, 13	#2710. . 11A, 109	#3719. . . . 69	#4466. . . . 133	#7180. . . 40, 156
#1394. . . . 164	#1824. . . . 164	#2223. . . 10, 12	#2711. . 109, 167	#3720. . . . 69	#4468. . . . 104	#7240. . . . 119
#1395. . . . 164	#1825. . . . 164	#2241. . . 124B	#2712. . 109, 167	#3721. . . . 69	#4470. . . . 130	#7284. . . . 158
#1396. . . . 164	#1826. . . . 164	#2242. . . 124B	#2714. . 109, 167	#3722. . . . 69	#4471. . . . 104	#7285. . . . 158
#1397. . . . 164	#1827. . . . 164	#2286. . . . 159	#2715. . 109, 167	#3723. . . . 69	#4473. . . . 131	#7286. . . . 158
#1398. . . . 164	#1828. . . . 164	#2290. . . . 163	#2721. . . . 109	#3724. . . . 69	#4474. . . . 120	#7288. . . . 158
#1399. . . . 164	#1829. . . . 164	#2291. . . . 163	#2726. . . . 108	#3725. . . 64, 155	#4478. . . . 104	#7327. . . . 118
#1400. . . . 99	#1830. . . . 59	#2292. . . . 163	#2777. . . . 108	#3726. . . . 65	#4482. . . . 143	#7371. . . . 118
#1401. . . . 75D	#1836. . . . 59	#2293. . . . 163	#2779. . . . 108	#3727. . . . 65	#4483. . . . 144	#7372. . . . 118
#1403. . . . 75J	#1843. . . . 158	#2294. . . . 163	#2807. . . . 46	#3730-31 SET 65	#4489. . . . 104	#7373. . . . 118
#1404. . . . 148	#1852. . . 38, 141	#2295. . . . 163	#2811. . . . 41	#3732-33 SET 65	#4490. . . . 147	#7374. . . . 118
#1408. . . . 148	#1854. . . . 164	#2296. . . . 163	#2834. . . . 151	#3734. . . . 65	#4494. . . . 133	#7375. . . . 118
#1409. . . . 87	#1855. . . . 164	#2300. . . 28, 41	#2928. . . . 151	#3735. . . 67, 131	#4498. . . . 146	#7376. . . . 118
#1416. . . . 75E	#1856. . . . 164	#2331. . . . 167	#2934. . . . 150	#3736. . . . 94	#4633. . . . 146	#7377. . . . 118
#1417. . . . 75C	#1857. . . . 164	#2332. . . . 167	#2937. . . . 150	#3738. . . . 131	#4683. . . . 144	#7378. . . . 118
#1420. . . . 75D	#1858. . . . 46	#2333. . . . 167	#2938. . . . 151	#3741. . . 94, 131	#4701. . . . 133	#7379. . . . 118
#1421. . . . 75D	#1858. . . . 164	#2464. . . . 165	#2939. . . . 150	#3742. . . . 94	#4705. . . . 125	#7440. . . . 119
#1423. . . . 75E	#1859. . . . 164	#2465. . . . 165	#2946. . . . 150	#3742-46 SET 94	#4707. . . . 124	#7510. . . . 119
#1424. . . . 154	#1861. . . . 138	#2466. . . . 165	#3002. . . . 10	#3743. . . . 94	#4709. . . . 125	#7540. . . . 119
#1443. . . . 127	#1875. . . . 143	#2468. . . . 165	#3003. . . . 12	#3750. . . 133, 141	#4710. . . . 125	#7550. . . . 119
#1444. . . . 164	#1878. . . . 148	#2474. . . . 165	#3009. . . . 12	#3751. . . . 104	#4712. . . . 124	#7640. . . . 119
#1445. . . . 164	#1879. . . . 148	#2475. . . . 165	#3010. . . . 7	#3751/71 SET104	#4714. . . . 121	#7701. . . . 93
#1446. . . . 164	#1886. . . . 143	#2476. . . . 165	#3011. . . . 8	#3752. . . . 104	#4716. . . . 121	#7707. . . . 93
#1447. . . . 164	#1887. . . 124B	#2478. . . . 165	#3012. . . 8, 19	#3752/72 SET104	#4718. . . . 120	#7712SET . . 93
#1448. . . . 164	#1889. . . . 145	#2481. . . . 116	#3020. . . . 95	#3753. . . . 105	#4719. . . . 133	#7713. . . . 78
#1449. . . . 164	#1896. . . . 143	#2482. . . . 116	#3025. . . . 95	#3753/73 SET105	#4720. . . . 154	#7715. . . . N/A
#1457 124A, 155	#1902. . . . 124	#2495. . . . 75C	#3026. . . . 95	#3754. . . . 105	#4721. . . . 133	#7717. . . . 87
#1458 113, 124A, 155	#1904. . . . 63B	#2496. . . . 75C	#3029. . . . 95	#3754/74 SET105	#4722. . . . 134	#7718. . . . 82
	#1908. . 148, 154	#2510. . . . 67	#3088. . . 68, 153	#3755. . . . 104	#4726. . . . 121	#7720. . . . 78
#1460. . . . 113	#1914. . 148, 154	#2511. . . . 67	#3101. . . . 32	#3755/75 SET104	#4731. . . . 121	#7726. . . . 77
#1463. . . . 113	#1916. . . . 149	#2512. . . . 165	#3105. . . . 31	#3756. . . . 104	#4737. . . . 146	#7727. . . . 81
#1464. . . . 109	#1921. . . . 75F	#2513. . . . 165	#3201. . . . 19	#3756/76 SET104	#4739. . . . 120	#7730. . . . 93
#1466. . . . 109	#1922. . . . 119	#2514. . . . 165	#3204. . . . 86	#3757. . . . 104	#4740. . . . 147	#7731. . . . 81
#1467. . . . 113	#1925. . . . 149	#2515. . . . 165	#3300. . . . 29	#3757/77 SET104	#4750. . . . 154	#7732. . . . 65
#1468. . . . 113	#1930. . . . 148	#2518. . . . 67	#3301. . . . 80	#3761. . . . 63B	#4751. . . . 146	#7735 SET . . 93
#1480. . . . 97	#1931. . . . 149	#2522. . . . 165	#3302. . . . 80	#3765. . . . 155	#4758. . . . 146	#7737. . . . 65
#1485. . . . 97	#1938. . . . 145	#2523. . . . 165	#3303. . . . 80	#3782. . . . 155	#4761. . . . 146	#7739. . . . 67
#1580. . . . 105	#1951. . . 124A	#2524. . . . 165	#3304. . . . 80	#3783. . . . 155	#4762. . . . 131	#7744. . . . 80
#1581. . . . 111	#1952. . . 124A	#2525. . . . 165	#3305. . . . 158	#3788. . . . 121	#4765. . . . 146	#7750. . . . 93
#1582. . . . 111	#1960. . . . 36	#2531. . . 124A	#3306. . 107, 158	#3792. . . . 155	#4766. . . . 146	#7752. . . . 78
#1583. . . . 110	#1981. . . . 161	#2532. . . 124A	#3308. . . . 158	#3793. . . . 155	#4767. . . . 146	#7755. . . . 93
#1584. . . . 111	#1982. . . . 161	#2550. . . . 48	#3310. . . . 12	#3818. . . . 47	#4768. . . . 131	#7759. . . . 87
#1585. . . . 111	#1983. . . . 161	#2602. . . . 165	#3315. . . . 80	#4010. . . . 13	#4773. . . . 75C	#7760. . . . 82
#1587. . . . 111	#2002. . . . 10	#2603. . . . 165	#3325. . . . 80	#4012. . . 13, 19	#4774. . . . 75A	#7765. . . 85, 158
#1588. . . . 111	#2010. . . . 7	#2604. . . . 165	#3331. . . . 125	#4202. . . . 160	#4783. . . . 154	#7768. . . . 90
#1589. . . . 111	#2011. . . . 8	#2605. . . . 165	#3332. . . . 125	#4350. . . . 12	#4787. . . . 131	#7770. . . . 35
#1620. . . . 26	#2012. . . 8, 19	#2612. . . . 165	#3333. . . . 125	#4380. . . . 12	#4788. . . . 131	#7771. . . . 144
#1621. . . . 26	#2022. . . . 13	#2613. . . . 165	#3407. . . . 86	#4387. . . . 124	#4791. . . . 154	#7774. . . . 124
#1622. . . 15, 25	#2023. . . . 75A	#2614. . . . 165	#3410. . . . 86	#4392. . . . 148	#4795. . . . 146	#7775. . . . 126
#1624. . . 26, 41	#2058. . . . 12	#2615. . . . 165	#3415. . . . 86	#4399. . . . 127	#4803. . . . 75	#7776. . . . 126
#1630. . . . 47	#2070. . . . 91	#2631. . . . 166	#3418. . . . 86	#4402. . . . 130	#4806. . . . 131	#7781. . . 45, 58
#1652. . . . 75	#2080. . . . 98	#2632. . . . 166	#3420. . . . 86	#4404. . . . 129	#7010. . 119, 156	#7791. . . . 114
#1710. . . . 108	#2083. . . . 153	#2633. . . . 166	#3425. . . . 86	#4405. . . . 121	#7022. . 119, 156	#7792. . . . 87
#1711. . . . 108	#2084. . . . 153	#2671. . . . 109	#3430. . 86, 141	#4416. . . . 63B	#7110. . 40, 156	#7797. . . . 114
#1712. . . . 108	#208868, 141, 153	#2672. . . . 109	#3440. . 86, 141	#4420. . . . 120	#7111. . 40, 156	#7806. . . . 132
#1720. . . 13, 40	#2091. . . . 153	#2680. . . . 115	#3441. . . . 141	#4421. . . . 63A	#7112. . . . 156	#7808. . . . 132
#1760. . . . 108	#2093. . . . 153	#2683. . . . 115	#3460. . 141, 158	#4428. . . . 120	#7115. . . . 156	#7816. . . . 132



Section:

Toll Free (800) 527-1318

Index

(972) 286-2368

Fax: (972) 557-4727



ALUMINUM CASTINGS

Part# . . . .Page#	Part# . . . .Page#	Part# . . . .Page#	Part# . . . .Page#	Part# . . . .Page#	Part# . . . .Page#
#7840. . . . 119	#8182. . . . 63A	#8307. . . . 88	#8507. . . . 75D	#9258. . . . 61, 141	#9618. . . . 156
#7940. . . . 119	#8188. . . . 63A	#8309. . . . 88	#8508. . . . 75D	#9260. . . . 61	#9634. . . . 149
#8001. . . . 87	#8201. . . . 81	#8310. . . . 88	#8509. . . . 75D	#9263. . . . 42	#9655. . . . 132
#8002. . . . 77	#8202. . . . 81	#8311. . . . 88	#8510. . . . 75D	#9264. . . . 59	#9660. . . . 114
#8003. . . . 87	#8203. . . . 83	#8314. . . . 88	#8512. . . . 79	#9267. . . . 77	#9661. . . . 114
#8004. . . . 78	#8204. . . . 83	#8316. . . . 88	#8533. . . . 74	#9269. . . . 59	#9662. . . . 114
#8005. . . . 87	#8205. . . . 83	#8317. . . . 88	#8540. . . . 74	#9270. . . . 84	#9669. . . . 144
#8006. . . . 77	#8206. . . . 83	#8319. . . . 88	#8559. . . . 47	#9272. . . . 40	#9675. . . . 126
#8007. . . . 78	#8207. . . . 83	#8340. .126, 156	#8560. . . . 74	#9275. . . . 81	#9677. . . . 120
#8008. . . . 78	#8208. . . . 81	#8344. .126, 156	#8561. . . . 89	#9281. . . . 163	#9688. . . . 120
#8009. . . . 78	#8209. . . . 82	#8345. .126, 156	#8562. . . . 89	#9281. . . 65, 163	#9692. . . . 147
#8010. . . . 78	#8210. . . . 84	#8346. .126, 156	#8569. . . 67,70	#9283. . . . 51	#9702 75G, 75H
#8011. . . . 78	#8211. . . . 82	#8370. . . . 156	#8570. . . . 74	#9284. . . . 57	#9709. . . . 147
#8012. . . . 78	#8212. . . . 81	#8374. . . . 156	#8580. . . . 74	#9285. . . . 57	#9713. . . . 120
#8013. . . . 78	#8213. . . . 83	#8375. . . . 156	#8582. . . . 74	#9286. . . . 80	#9716. . . . 120
#8016. . . . 99	#8214. . . . 81	#8376. . . . 156	#8590. . . . 74	#9288. . . . 60	#9718. . . . 145
#8021 75G, 75H	#8215. . . . 83	#8380. .127, 156	#8610. . . . 75A	#9291. . . . 132	#9733. 11A, 141
#8025. . . . 141	#8216. . . . 128A	#8384. .127, 156	#8618. . . . 94	#9294. . . . 54	#9734. .130, 156
#8033. . . . 87A	#8218. . . . 128	#8385. .127, 156	#8620. . . . 75D	#9295. . . . 144	#9741. .154, 166
#8034 75G, 75H	#8219. . . . 128	#8386. .127, 156	#8625. . . . 75E	#9298. . . . 99	#9742. .154, 166
#8037. . . . 149	#8223. . . . 83	#8390. . . . 156	#8725. . . . 75E	#9299. . . . 124	#9743. .154, 166
#8038 75G, 75H	#8226. . . . 128	#8394. . . . 156	#8844. . . . 123	#9300. .122, 141	#9746. . . . 147
#8040. . . . 87	#8227. . . . 129	#8395. . . . 156	#8846. . . . 123	#9302. . . . 63B	#9756. . . . 123
#8042. . . . 141	#8228. . . . 128A	#8396. . . . 156	#8847. . . . 123	#9304. . . . 127	#9767. . . . 146
#8044 75G, 75H	#8233. . . . 128A	#8400. . . . 75I	#8848. . . . 123	#9305. . . . 127	#9770. . . . 147
#8045. . . . 141	#8234. . . . 128	#8401. . . . 75I	#8849. . . . 123	#9307. . . . 130	#9775. .119, 156
#8046 75G, 75H	#8235. . . . 128	#8402 43,67,70,156	#8906. . . . 75	#9318. . . . 145	#9785. . . . 57
#8047. . . . 75H	#8236. . . . 128A	#8405. . . 43,67	#8912. . . . 75C	#9319. . . . 125	#9826. . . . 11A
#8054. . . . 87	#8238. . . . 83	#8406. . . 43, 133	#9020. . . . 149	#9320. . . . 112	#9840. . . . 75F
#8055. . . . 87	#8241. . . . 128	#8407. . . . 43	#9030. . . . 122	#9332. . . . 85	#9845. . . . 63B
#8056 75G, 75H	#8243. . . . 128	#8408. . . . 43	#9032. . . . 135	#9333. . . . 86	#9915. . . . 75C
#8057. . . . 87	#8244. . . . 129	#8409. . . . 43	#9033. . . . 153	#9334. .119, 156	#9974. . . . 152
#8060. . . . 127	#8245. . . . 129	#8410. . . . 75I	#9051. . . . 75	#9350. .122, 141	#9977. . . . 119
#8061. . . . 141	#8247. . . . 128A	#8411. . . . 43	#9055. . . . 113	#9365. . . . 127	
#8066. . . . 75G	#8248. . . . 128A	#8412. .43,66,67	#9056. . . . 113	#9366. . . . 127	
#8071 75G, 75H	#8253. . . . 84	#8413. . . . 43,66	#9057. . . . 113	#9367. . . . 144	
#8075. . . . 87A	#8255. . . . 129	#8417. . 75I, 154	#9069. . . . 63A	#9369. . . . 144	
#8077 75G, 75H	#8256. . . . 83	#8419. . . . 75I	#9070. . . . 63B	#9378. . . . 147	
#8078 75G, 75H	#8258. . . . 128A	#8420. . . . 75A	#9072. . . . 87	#9382. . . . 123	
#8112. . . . 63A	#8259. . . . 129	#8421. . . . 75A	#9080. . . . 124	#9386. . . . 135	
#8115. . . . 63	#8261. . . . 81	#8423. . . . 75B	#9085. . . . 149	#9400. . . . 153	
#8116. . . . 63	#8262. . . . 81	#8424. . . . 75B	#9089. .147, 167	#9401. . . . 145	
#8117. . . . 63	#8264. . . . 83	#8425. . . . 75A	#9112. . . . 148	#9402. . . . 145	
#8118. . . . 62	#8265. . . . 128A	#8426. . . . 75A	#9113. . . . 90	#9403. . . . 145	
#8119. . . . 63	#8266. . . . 84	#8430. . . . 75A	#9125. . . . 130	#9410. . . . 135	
#8120. . . . 63	#8268. . . . 81	#8431. . . . 75I	#9134. . . . 89	#9429. . . . 153	
#8121. . . . 70	#8271. . . . 148	#8441. . . . 75I	#9154. . . . 90	#9430. . . . 11A	
#8122. . . . 63	#8272. . . . 128	#8442. .130, 156	#9184. . . . 90	#9435. . . . N/A	
#8124. . . . 63	#8273. . . . 128	#8443. . . . 156	#9193. . . . 60	#9437. .133, 141	
#8125. . . . 62	#8274. . . . 128A	#8445. . . . 130	#9194. . . . 74	#9440. . . . N/A	
#8126. . . . 63	#8275. . . . 128B	#8450. . . . 75	#9201. . . . 75J	#9482. .154, 166	
#8127. . . . 63	#8276. . . . 128B	#8451. . . . 75	#9202. . . . 90	#9483. .154, 166	
#8128. . . . 63	#8277. . . . 63B	#8460. . . . 75	#9203. . . . 90	#9489. . . . 128A	
#8131. . . . 63A	#8278. . . . 148	#8466. . . . 75I	#9208. . . . 124B	#9493. . . . 152	
#8132. . . . 63A	#8280. . . . 148	#8470. . . . 75A	#9209. . . . 60	#9495. . . . 63B	
#8133. . . . 63B	#8281. . . . 128	#8471. . . . 75A	#9218. . . . 75A	#9513. . . . 141	
#8136. . . . 63B	#8282. . . . 128	#8472. . . . 75A	#9219. . . . 51	#9527. . . . 123	
#8137. . . . 63A	#8283. . . . 129	#8480. . . . 75B	#9222. . . . 51	#9528. . . . 123	
#8139. . . . 63A	#8284. . . . 129	#8481. . . . 75B	#9231. . . . 51	#9530. . . . 132	
#8144. . . . 63A	#8285. . . . 128A	#8487. . . . 75B	#9232. . . . 55	#9533. . . . 11A	
#8145. . . . 63B	#8288. . . . 128A	#8488. . . . 75B	#9237 42,70, 156	#9547. . . . 149	
#8148. . . . 63B	#8291. . . . 128	#8489. . . . 75B	#9238. . . . 60	#9549. . . . 134	
#8149. . . . 63A	#8293. . . . 128A	#8490. . . . 75C	#9243. . . . 58,89	#9570. . . . 141	
#8152. . . . 63A	#8294. . . . 129	#8491. . . . 75C	#9244. . . . 70	#9571. . . . 114	
#8160. . . . 132	#8295. . . . 128B	#8494. . . . 76	#9245. . . 62, 132	#9572. . . . 114	
#8164. . . . 132	#8296. . . . 128A	#8496. . . . 75C	#9246. . . . 62	#9583. . . . 120	
#8165. . . . 132	#8298. . 99, 128	#8497. . . . 75C	#9247. . . . 89	#9584. . . . 120	
#8166. . . . 132	#8299. . . . 129	#8498. . . . 75D	#9250. . . . 61	#9603. . . . 144	
#8170. . . . 63A	#8304. . . . 88	#8500. . . . 75D	#9254. . . . 51	#9605. . . . 127	
#8177. . . . 144	#8305. . . . 88	#8501. . . . 75D	#9255. . . . 91	#9609. . . . 141	
#8178. . . . 144	#8306. . . . 88	#8505. . . . 75D	#9256. . . . 141	#9609. . . . 147	





# Alloy Casting

## ALUMINUM CASTINGS

Toll Free (800) 527-1318

(972) 286-2368

Fax: (972) 557-4727

Section:

Custom Castings

### Custom Castings

Custom requirements can be quoted from a sketch or drawing. A faxed transmittal is sufficient most of the time. The quote will include a turn key project from creation of master patterns, fabrication of tooling, to manufacturing of the final casting. Alloy Casting can quote on finishing, but history has shown that finishing closer to actual installation provides more control to the designer.

Custom projects typically take from 5-16 weeks with overall time a function of the time necessary to create the master pattern.

**Basic Use:** Aluminum castings can be used for architectural, ornamental, decorative and furniture applications. New custom castings can be easily created. The castings can be used in:

- Handrails
- Fences
- Gates
- Stairways
- Drapery rod enhancements
- Furniture legs/backseats
- Furniture ornaments
- Tree grates
- Plaques
- Awards
- Tables/benches/chairs
- Window enhancements
- Wall Sculptures

And it can consist of aluminum castings made as:

- Logos
- Ballisters
- Finials
- Rosettes
- Wall decorations
- Flanges
- Ballister collars
- Spear tops
- Picket castings
- Panel castings
- Furniture parts

Customization of Aluminum castings can occur in many ways. One way is to design a new casting for a common application. This could be: a new fence panel design, a new spear point, a new bench end, or a bas-relief sculpted plaque.

An alternative way of customizing is to cast a three dimensional logo onto existing designs.

A third method of customizing is to combine the two previous methods and add a unique logo to a newly created bench end, table, trash can holder, or other items. This method is commonly used and greatly enhances the common theme of a project.

**Composition and Material:**

Aluminum Castings are made by the green sand mold method. Castings are cleaned by sand blasting and parting lines are then cleaned and deburred.

**Aluminum Grades:** Aluminum Association alloys 319, 356, and 514 are available on a certified basis. Other alloys can be cast upon request. A standard blended alloy is available for non-critical, non-certified applications.

**Sizes:** Castings range from 1"x 1"x 1" (0.1 lb.) to 48"x48"x2" (350 lbs.). Cores are used for horizontal holes and tight fit applications.

**Finishes:** The surface has an "as cast" texture. The surface can be sanded, ground, and polished with different grits and wire sizes. Castings are readily painted and coated via:

- Fluoropolymers
- Powder coats
- Paints
- Antiquing
- Electroplating

**Limitations:** Caution should be used in coastal applications where salt spray can cause electrolysis between dissimilar metals. Aluminum

castings also provide poor anodizing characteristics.

**Physical and Chemical Properties:** Aluminum Association Chemical specifications certified as needed for specific applications. See Table 1.

**Welding/Fabrication:** Aluminum castings can be welded to other forms of aluminum (i.e., tubing, plate, sheet), but cannot be welded directly to steel. To overcome this limitation a steel tab or stub can be cast into the aluminum. That insert can then be welded to steel.

In addition to welding aluminum to aluminum, or steel inserts to steel, the castings can easily be drilled and threaded for bolt type attachments. Aluminum is easily sawed with a band saw and is easily machined.

**Packaging and Shipping:** Fiberboard drums and boxes from 100 lbs. to 300 lbs. Pallet boxes of 40"x48"x26" strapped to pallets for shipments of 800-1200 lbs. Shipping is via UPS and common carrier.

**Maintenance:** Surface Maintenance requirements are determined by the coating manufacturer. Aluminum will not rust and with a coherent contact coating it will not corrode, even in a sea coast environment.

**Technical Services:**

A metallurgical engineer is on staff to answer any questions. Matchplate tooling is fabricated in-house. Local subcontractors have been educated to provide the proper drafts and dimensions for original wood carvings and master patterns.

**TABLE 1**  
SAND CASTING-AS CAST STRUCTURE  
(F-TEMPER)

		ALUMINUM ALLOY		
		319	356	514
Tensile Strength (1000 PSI)		23.0	19.0	22.0
Yield Strength (1000 PSI)		13.0	-	9.0
Major Alloying Elements Nominal %	Silicon	6.0	7.0	--
	Copper	3.5	0.3	--
	Magnesium	--	--	4.0
<b>Characteristics (1 is Better)</b>				
Corrosion Resistance		3	2	1
Machinability		3	3	1
Polishing		4	4	1
Weldability		2	1	3
Cost		1	2	4

Other alloys are available upon request.  
Information source: Aluminum Association Standards 11th edition, 1986



Section:

Toll Free (800) 527-1318

(972) 286-2368

Fax: (972) 557-4727

Comments



**Jon McGraw**  
Sales



**Ken Buxton**  
Production/  
Sales



**Juan Acosta**  
Production/  
Customization



**Joe Foster**  
Production



**Jeri Prather**  
Office



**Weldon Starnes**  
Maintenance

## Comments

A few comments for you about this catalog from the Management Group at *Alloy Casting*.

This Catalog comes to you as we celebrate our 50th year producing ornamental aluminum castings.

The catalog is arranged by topic and has been carefully put together to make it easy for you to find the items required in your business. We are proud to have included in this catalog over 350 items that have not been in our other catalogs. Many of these items are not only new to *Alloy Casting* but are new to the industry as well. Each new item has been labeled "NEW" under the product number. A review of these items could be of special interest to you.

Many of these new items have been custom created by fabricators and manufactures as they have searched for something new to offer their customers. *Alloy Casting* has implemented these projects on a turn key basis. More information on our turn key abilities are discussed on page 5. We also have brochures entitled "Creativity that is Custom Cast" and, "Aluminum, .. Furniture's Alternative to Wood", that are available for your use. Just ask and we will send you copies.

We have prepared this catalog with you in mind. If you have any suggestions how we might make it easier and more profitable for you, please let us know.

We are proud to be known for our quality castings delivered in a prompt manner.

Jon McGraw

## "Made in U. S. A."



American  
Foundry  
Society



American  
Fence  
Association



NOMMA



Texas Cast  
Metal  
Association



Construction  
Specifiers  
Institute





# Alloy Casting

## ALUMINUM CASTINGS

Toll Free (800) 527-1318

(972) 286-2368

Fax: (972) 557-4727

Section:

1/2 Inch Picket Castings

**1** **DF**  
]1/2" [

HEIGHT	13 3/4 IN	34.9 CM
WIDTH	6 1/2 IN	16.5 CM
THICK	3/4 IN	1.9 CM
WEIGHT	1.0 LBS	0.5 KGS

**2** **DF**  
]1/2" [

GUARDIAN

SEE PAGES 10 AND 11 FOR MANY MORE MATCHING SELECTIONS. FOR WIDER PICKET SIZE SELECTIONS SEE PAGES 12 AND 13.

HEIGHT	17 3/4 IN	45.1 CM
WIDTH	7 7/8 IN	20.0 CM
THICK	3/4 IN	1.9 CM
WEIGHT	1.2 LBS	0.6 KGS

**3** **SF**  
]1/2" [

CAPRI

FOR WIDER PICKET SIZE SELECTIONS SEE PAGES 12 AND 13.

HEIGHT	13 3/4 IN	34.9 CM
WIDTH	7 1/4 IN	20.0 CM
THICK	3/4 IN	1.9 CM
WEIGHT	1.0 LBS	0.5 KGS

**4** **DF**  
]1/2" [

HEIGHT	14 1/2 IN	36.8 CM
WIDTH	7 7/8 IN	20.0 CM
THICK	3/4 IN	1.9 CM
WEIGHT	1.9 LBS	1.0 KGS

**5** **SF**  
]1/2" [

HEIGHT	14 1/8 IN	35.9 CM
WIDTH	7 7/8 IN	20.0 CM
THICK	3/4 IN	1.9 CM
WEIGHT	1.0 LBS	0.4 KGS

**6** **SF**  
]1/2" [

HEIGHT	12 3/8 IN	45.1 CM
WIDTH	8 1/4 IN	31.4 CM
THICK	3/4 IN	1.9 CM
WEIGHT	0.8 LBS	0.3 KGS

**7** **SF**  
]1/2" [

HEIGHT	15 1/4 IN	38.7 CM
WIDTH	8 1/4 IN	21.0 CM
THICK	3/4 IN	1.9 CM
WEIGHT	1.5 LBS	0.7 KGS

**8** **SF**  
]1/2" [

HEIGHT	15 3/4 IN	40.0 CM
WIDTH	7 5/8 IN	19.4 CM
THICK	3/4 IN	1.9 CM
WEIGHT	1.1 LBS	0.5 KGS

**9** **SF**  
]1/2" [

SCALE 2 INCHES = 1 FOOT

FOR WIDER PICKET SIZE SELECTIONS, SEE PAGES 12 AND 13.

HEIGHT	6 1/4 IN	15.9 CM
WIDTH	7 7/8 IN	20.0 CM
THICK	3/4 IN	1.9 CM
WEIGHT	0.6 LBS	0.3 KGS

**10** **SF**  
]1/2" [

SCALE 2 INCHES = 1 FOOT

FOR WIDER PICKET SIZE SELECTIONS, SEE PAGES 12 AND 13.

HEIGHT	4 IN	10.2 CM
WIDTH	4 1/4 IN	10.8 CM
THICK	7/8 IN	2.2 CM
WEIGHT	0.3 LBS	0.1 KGS

**2010** **SF**  
OLD 10X2 ]1/2" [

SCALE 2 INCHES = 1 FOOT

HEIGHT	3 3/4 IN	9.5 CM
WIDTH	3 3/4 IN	9.5 CM
THICK	3/4 IN	1.9 CM
WEIGHT	0.2 LBS	0.1 KGS

**3010** **SF**  
OLD 10X3 ]1/2" [

SCALE 2 INCHES = 1 FOOT

HEIGHT	3 IN	7.6 CM
WIDTH	3 IN	7.6 CM
THICK	1/2 IN	1.3 CM
WEIGHT	0.2 LBS	0.1 KGS

REVISION DATE: 01/18/95

SCALE: 1 INCH = 1 FOOT UNLESS NOTED





**Alloy Casting**

**ALUMINUM CASTINGS**

**1/2 Inch Picket Castings**

**11** **DF**  
]1/2"["

HEIGHT 10 IN 25.4 CM  
WIDTH 8 1/4 IN 21.0 CM  
THICK 3/4 IN 1.9 CM  
WEIGHT 0.8 LBS 0.4 KGS

**2011** **DF**  
OLD 11X2 ]1/2"["

HEIGHT 17 3/4 IN 45.1 CM  
WIDTH 8 IN 20.3 CM  
THICK 3/4 IN 1.9 CM  
WEIGHT 1.6 LBS 0.7 KGS

**3011** **DF**  
OLD 11X3 ]1/2"["

HEIGHT 16 IN 40.6 CM  
WIDTH 8 3/8 IN 21.3 CM  
THICK 7/8 IN 2.2 CM  
WEIGHT 1.3 LBS 0.6 KGS

**19** **DF**  
]1/2"["

HEIGHT 14 IN 35.6 CM  
WIDTH 5 1/2 IN 14.0 CM  
THICK 5/8 IN 1.6 CM  
WEIGHT 1.0 LBS 0.4 KGS

**12** **DF**  
]1/2"["

EXTRA THICK

HEIGHT 16 5/8 IN 42.2 CM  
WIDTH 8 1/4 IN 21.0 CM  
THICK 7/8 IN 2.2 CM  
WEIGHT 2.6 LBS 1.2 KGS

**2012** **SBO**  
OLD 12X2 ]1/2"["

SEE PAGE 13 FOR THIS PICKET WITH HOLES IN THE LUG.

HEIGHT 16 5/8 IN 42.2 CM  
WIDTH 8 1/4 IN 21.0 CM  
THICK 7/8 IN 2.2 CM  
WEIGHT 2.1 LBS 1.0 KGS

**3012** **DF**  
OLD 12X3 ]1/2"["

HEIGHT 16 5/8 IN 42.2 CM  
WIDTH 8 1/4 IN 21.0 CM  
THICK 7/8 IN 2.2 CM  
WEIGHT 2.1 LBS 1.0 KGS

**22** **DF**  
]1/2"["

SEE PAGE 13 FOR THIS PICKET WITH HOLES IN THE LUG.

HEIGHT 15 IN 38.1 CM  
WIDTH 7 3/4 IN 19.7 CM  
THICK 3/4 IN 1.9 CM  
WEIGHT 2.1 LBS 1.0 KGS

**17** **SF**  
]1/2"["

HEIGHT 18 1/8 IN 46.0 CM  
WIDTH 7 IN 17.8 CM  
THICK 3/4 IN 1.9 CM  
WEIGHT 1.5 LBS 0.7 KGS

**18** **SF**  
]1/2"["

HEIGHT 18 1/8 IN 46.0 CM  
WIDTH 7 IN 17.8 CM  
THICK 3/4 IN 1.9 CM  
WEIGHT 1.5 LBS 0.7 KGS

**21** **DF**  
]1/2"["

HEIGHT 16 1/4 IN 41.3 CM  
WIDTH 7 3/8 IN 18.7 CM  
THICK 3/4 IN 1.9 CM  
WEIGHT 1.6 LBS 0.7 KGS

**23** **DF**  
]1/2"["

HEIGHT 18 1/8 IN 46.0 CM  
WIDTH 7 IN 17.8 CM  
THICK 3/4 IN 1.9 CM  
WEIGHT 1.5 LBS 0.7 KGS



# Alloy Casting

## ALUMINUM CASTINGS

Toll Free (800) 527-1318

(972) 286-2368

Fax: (972) 557-4727

Section:

## 1/2 Inch Picket Castings

**24** **DF**  
]1/2" [

HEIGHT 14 7/8 IN 37.8 CM  
WIDTH 8 1/8 IN 20.6 CM  
THICK 3/4 IN 1.9 CM  
WEIGHT 1.2 LBS 0.6 KGS

**25** **SF**  
]1/2" [

HEIGHT 7 1/4 IN 18.4 CM  
WIDTH 4 1/2 IN 11.4 CM  
THICK 3/4 IN 1.9 CM  
WEIGHT 0.5 LBS 0.2 KGS

**26** **DF**  
]1/2" [

HEIGHT 14 1/2 IN 36.8 CM  
WIDTH 5 5/8 IN 14.0 CM  
THICK 5/8 IN 1.6 CM  
WEIGHT 1.2 LBS 0.6 KGS

**31** **DF**  
]1/2" [

BIRD OF PARADISE

HEIGHT 14 1/4 IN 33.2 CM  
WIDTH 7 7/8 IN 20.0 CM  
THICK 3/4 IN 1.9 CM  
WEIGHT 1.6 LBS 0.7 KGS

**28** **SF**  
]1/2" [

HEIGHT 6 3/4 IN 17.1 CM  
WIDTH 6 3/4 IN 17.1 CM  
THICK 3/4 IN 1.9 CM  
WEIGHT 1.1 LBS 0.6 KGS

**180** **SF**  
NEW ]1/2" [

SEE PAGE NO 13 FOR THIS PIECE WITH HOLE IN LUG.

HEIGHT 13 1/4 IN 33.7 CM  
WIDTH 7 3/8 IN 18.7 CM  
THICK 3/4 IN 1.9 CM  
WEIGHT 1.5 LBS 0.7 KGS

**20** **SF**  
]1/2" [

HEIGHT 16 3/8 IN 18.4 CM  
WIDTH 7 IN 11.4 CM  
THICK 5/8 IN 1.9 CM  
WEIGHT 1.3 LBS 0.6 KGS

**29** **SF**  
]1/2" [

HEIGHT 12 IN 30.5 CM  
WIDTH 5 7/8 IN 14.4 CM  
THICK 3/4 IN 1.9 CM  
WEIGHT 0.6 LBS 0.3 KGS

**77** **DF**  
NEW ]1/2" [

HEIGHT 18 7/8 IN 52.4 CM  
WIDTH 8 IN 19.7 CM  
THICK 1 IN 2.5 CM  
WEIGHT 3.2 LBS 1.5 KGS

**223** **DF**  
NEW ]1/2" [

THIS CASTING WILL NOT ACCEPT A STEEL CLIP.

SECTION A-A  
DIAMOND CROSS SECTION.

HEIGHT 17 3/4 IN 18.4 CM  
WIDTH 8 IN 11.4 CM  
THICK 5/8 IN 1.9 CM  
WEIGHT 1.3 LBS 0.6 KGS

**32** **SF**  
]1/2" [

HEIGHT 13 IN 33.0 CM  
WIDTH 6 3/4 IN 17.1 CM  
THICK 3/4 IN 1.9 CM  
WEIGHT 1.0 LBS 0.4 KGS



Bird of Paradise Picket casting #31 in a roof fence rail

REVISION DATE: 01/18/95

SCALE: 1 INCH = 1 FOOT UNLESS NOTED



Section:

Guardian style  
Castings

Toll Free (800) 527-1318

(972) 286-2368

Fax: (972) 557-4727



ALUMINUM CASTINGS

**2** **DF**  
]1/2" [



GUARDIAN

HEIGHT	17 3/8 IN	45.1 CM
WIDTH	7 7/8 IN	20.0 CM
THICK	3/4 IN	1.9 CM
WEIGHT	1.2 LBS	0.3 KGS

**32** **SF**  
]1/2" [



HEIGHT	13 IN	33.0 CM
WIDTH	6 3/4 IN	17.1 CM
THICK	3/4 IN	1.9 CM
WEIGHT	1.0 LBS	0.5 KGS

**224** **DF**  
NEW ]1/2" [



HEIGHT	8 3/8 IN	17.5 CM
WIDTH	6 7/8 IN	21.3 CM
THICK	3/4 IN	1.9 CM
WEIGHT	0.7 LBS	0.3 KGS

**225** **DF**  
NEW ]1/2" [



HEIGHT	5 IN	12.7 CM
WIDTH	6 3/4 IN	17.1 CM
THICK	3/4 IN	1.9 CM
WEIGHT	0.6 LBS	0.2 KGS

**226** **DF**  
NEW ]1/2" [



HEIGHT	5 IN	12.7 CM
WIDTH	6 3/4 IN	17.1 CM
THICK	3/4 IN	1.9 CM
WEIGHT	0.6 LBS	0.3 KGS

**227** **DF**  
NEW ]1/2" [



HEIGHT	8 7/8 IN	22.5 CM
WIDTH	6 5/8 IN	16.8 CM
THICK	3/4 IN	1.9 CM
WEIGHT	0.7 LBS	0.3 KGS

**3002** **DF**  
NEW ]1/2" [

THIS PIECE WILL NOT ACCEPT A STEEL CLIP.



LUG IS ON THE FRONT.

HEIGHT	17 3/8 IN	45.1 CM
WIDTH	7 7/8 IN	20.0 CM
THICK	3/4 IN	1.9 CM
WEIGHT	1.2 LBS	0.6 KGS

**2002** **DF**  
OLD 2X2 ]1/2" [



HEIGHT	16 5/8 IN	42.2 CM
WIDTH	7 3/8 IN	8.7 CM
THICK	3/4 IN	1.9 CM
WEIGHT	1.0 LBS	0.5 KGS

**2223** **DF**  
OLD 2P34 ]3/4" [



THIS PIECE FITS A 3/4 INCH SQUARE BAR.

HEIGHT	17 IN	43.2 CM
WIDTH	8 1/8 IN	20.6 CM
THICK	3/4 IN	1.9 CM
WEIGHT	1.2 LBS	0.6 KGS

**2222** **DF**  
NEW ]1/2" [



THIS PIECE HAS HOLE IN LUGS.

HEIGHT	15 7/8 IN	42.2 CM
WIDTH	6 7/8 IN	18.7 CM
THICK	3/4 IN	1.9 CM
WEIGHT	1.0 LBS	0.5 KGS

Picket casting #2 and #224 in a pool gate.

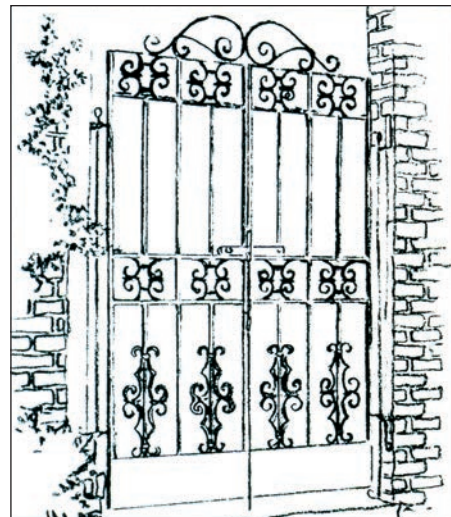

REVISION DATE: 01/18/95

GUARDIAN PICKETS: FOR LARGER SLOT PICKETS SEE PAGE 12.



**ALUMINUM CASTINGS**

Toll Free (800) 527-1318

(972) 286-2368

Fax: (972) 557-4727

Section:

**Guardian Style  
Castings**

**220**

**DF**

OLD 220B



HEIGHT 14 7/8 IN	37.8 CM
WIDTH 14 7/8 IN	37.8 CM
THICK 3/4 IN	1.9 CM
WEIGHT 1.9 LBS	0.3 KGS

**221**

**DF**

OLD 221F



HEIGHT 3 1/2 IN	8.9 CM
WIDTH 25 1/2 IN	64.8 CM
THICK 3/4 IN	1.9 CM
WEIGHT 1.6 LBS	0.7 KGS

**422**

NEW

**DF**

] 1/2 "[



HEIGHT 4 1/4 IN	10.8 CM
WIDTH 28 1/8 IN	71.4 CM
THICK 1 IN	2.5 CM
WEIGHT 2.7 LBS	1.2 KGS

PIECE FITS OVER A 1/2 INCH  
HORIZONTAL SQUARE BAR.

REVISION DATE:12/07/94

SCALE: 1 INCH = 1 FOOT UNLESS NOTED





**FLAT BACK**



**FLAT TOP & BOTTOM**

**33**

HEIGHT: 4"  
 WIDTH: 2"  
 THICK: 1/2"  
 WEIGHT: 0.2 lbs

**DOUBLE FACE**



**333**

HEIGHT: 5"  
 WIDTH: 4.5"  
 THICK: 3/4"  
 WEIGHT: .7 lbs

**FLAT BACK**



**633**

HEIGHT: 8 1/4"  
 WIDTH: 4 5/8"  
 THICK: 1/2"  
 WEIGHT: 0.6 lbs

**DOUBLE FACE**



**RD SECTION 1/2 BAR SLOT**

**9430**

HEIGHT: 6 1/2"  
 WIDTH: 8 1/2"  
 THICK: 1/2"  
 WEIGHT: 0.9 lbs

**DOUBLE FACE**



**NOT SYMETRICAL**

**9733**

HEIGHT: 5 3/4"  
 WIDTH: 3 1/8"  
 THICK: 3/4"  
 WEIGHT: 0.6 lbs

**DOUBLE FACE**



**9826**

HEIGHT: 6"  
 WIDTH: 3 1/2"  
 THICK: 7/8"  
 WEIGHT: 0.70 lbs

**DOUBLE FACE**



**9533**

HEIGHT: 4"  
 WIDTH: 2"  
 THICK: 3/8"  
 WEIGHT: 0.2 lbs



**2709**

HEIGHT: 7 1/4"  
 WIDTH: 3 1/2"  
 THICK: 0  
 WEIGHT: 0



**2710**

HEIGHT: 4 1/2"  
 WIDTH: 2 1/2"  
 THICK: 0  
 WEIGHT: 0

**C SCROLL ENDS FLARED**



**1331**

HEIGHT: 4 1/2"  
 WIDTH: 2 1/2"  
 THICK: 1/2"  
 WEIGHT: 0.2 lbs

**C SCROLL ENDS FLARED**



**1333**

HEIGHT: 7 1/4"  
 WIDTH: 3 1/2"  
 THICK: 1/2"  
 WEIGHT: 0.3 lbs





Section:

5/8, 3/4, And 1 Inch  
Picket Castings

Toll Free (800) 527-1318

(972) 286-2368

Fax: (972) 557-4727



**2058** **DF**  
NEW **5/8"**

HEIGHT 17 3/8 IN 44.1 CM  
WIDTH 7 5/8 IN 19.4 CM  
THICK 3/4 IN 1.9 CM  
WEIGHT 1.3 LBS 0.6 KGS

**4350** **SF**  
NEW **5/8"**

NOTE: SCALE: 1 INCH = 6 INCHES

HEIGHT 4 IN 10.1 CM  
WIDTH 4 5/8 IN 11.7 CM  
THICK 3/4 IN 1.9 CM  
WEIGHT 0.3 LBS 0.1 KGS



Picket castings #2 and #9 combined with spear point #8206 as a window guard.

**1001** **SF**  
NEW

HEIGHT 13 3/4 IN 34.9 CM  
WIDTH 6 3/4 IN 17.1 CM  
THICK 3/4 IN 1.9 CM  
WEIGHT 1.0 LBS 0.5 KGS

**2223** **DF**  
OLD 2P34

HEIGHT 17 IN 43.2 CM  
WIDTH 7 7/8 IN 21.6 CM  
THICK 3/4 IN 1.9 CM  
WEIGHT 1.3 LBS 0.6 KGS

**3003** **SF**  
OLD 3P34

HEIGHT 13 3/4 IN 34.9 CM  
WIDTH 7 5/8 IN 19.7 CM  
THICK 3/4 IN 1.9 CM  
WEIGHT 1.1 LBS 0.6 KGS

**3009** **SF**  
OLD 9P34

HEIGHT 6 IN 15.2 CM  
WIDTH 8 1/8 IN 20.6 CM  
THICK 3/4 IN 1.9 CM  
WEIGHT 0.6 LBS 0.3 KGS

**3310** **SF**  
OLD 10P34 **3/4"**

NOTE: SCALE: 1 INCH = 6 INCHES

HEIGHT 4 IN 34.9 CM  
WIDTH 4 3/8 IN 17.1 CM  
THICK 3/4 IN 1.9 CM  
WEIGHT 0.3 LBS 0.5 KGS

**1002** **DF**  
NEW **1"**

HEIGHT 16 7/8 IN 42.9 CM  
WIDTH 8 IN 20.3 CM  
THICK 3/4 IN 1.9 CM  
WEIGHT 1.6 LBS 0.7 KGS

**4380** **SF**  
NEW **1"**

NOTE: SCALE: 1 INCH = 6 INCHES

HEIGHT 4 IN 10.1 CM  
WIDTH 4 5/8 IN 11.7 CM  
THICK 3/4 IN 1.9 CM  
WEIGHT 0.3 LBS 0.1 KGS

REVISION DATE: 01/12/95

SCALE: 1 INCH = 1 FOOT UNLESS NOTED

**2222**  
NEW

**DF**  
] 1/2" [



HEIGHT 15 7/8 IN 44.1 CM  
WIDTH 6 7/8 IN 20.0 CM  
THICK 3/4 IN 1.9 CM  
WEIGHT 1.0 LBS 0.6 KGS

**1003**  
NEW

**SF**  
] 1/2" [



HEIGHT 13 3/4 IN 34.9 CM  
WIDTH 8 3/8 IN 20.0 CM  
THICK 3/4 IN 1.9 CM  
WEIGHT 1.0 LBS 0.5 KGS

**4010**  
OLD 10X4

**SF**  
] 1/2" [



HEIGHT 3 3/4 IN 9.5 CM  
WIDTH 4 1/8 IN 10.8 CM  
THICK 3/4 IN 1.9 CM  
WEIGHT 0.3 LBS 0.1 KGS

**4012**  
OLD 12X4

**DF**  
] 1/2" [



HEIGHT 16 5/8 IN 42.2 CM  
WIDTH 8 1/4 IN 21.0 CM  
THICK 3/4 IN 1.9 CM  
WEIGHT 2.1 LBS 1.0 KGS

**1243**  
OLD C243

**DF**  
] 1/2" [



HEIGHT 33 1/4 IN 84.5 CM  
WIDTH 7 3/4 IN 19.7 CM  
THICK 3/4 IN 1.9 CM  
WEIGHT 4.8 LBS 2.2 KGS

**2022**  
OLD 22X2

**DF**  
] 1/2" [



HEIGHT 15 IN 38.1 CM  
WIDTH 7 3/4 IN 19.7 CM  
THICK 3/4 IN 1.9 CM  
WEIGHT 2.1 LBS 1.0 KGS

**1180**  
NEW

**SF**  
] 1/2" [

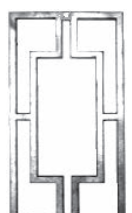

HEIGHT 13 1/4 IN 33.7 CM  
WIDTH 7 3/8 IN 18.7 CM  
THICK 3/4 IN 1.9 CM  
WEIGHT 1.5 LBS 0.7 KGS

**1720**  
NEW

**SF**  
] 1/2" [

NOMINAL PICKET

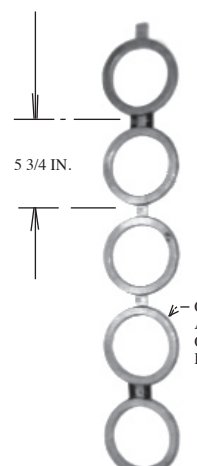

5 3/4 IN.

CIRCLES ARE 5 1/8 IN. OUTSIDE DIAMETER.

LUGS BETWEEN CIRCLES HAVE 1 1/8 INCH TAPERED HOLES FOR SCREW ON APPLICATIONS.

HEIGHT 28 1/4 IN 71.8 CM  
WIDTH 5 1/8 IN 13.0 CM  
THICK 1/2 IN 1.3 CM  
WEIGHT 2.1 LBS 1.0 KGS

**422**  
NEW

**DF**  
] 1/2" [



HEIGHT 4 1/4 IN 10.8 CM  
WIDTH 28 1/8 IN 71.4 CM  
THICK 1 IN 2.5 CM  
WEIGHT 2.7 LBS 1.2 KGS

PIECE FITS OVER A 1/2 INCH HORIZONTAL SQUARE BAR.

**426**  
NEW

**DF**  
] 1/2" [



HEIGHT 4 IN 25.8 CM  
WIDTH 28 5/8 IN 72.7 CM  
THICK 1 IN 2.5 CM  
WEIGHT 2.0 LBS 0.9 KGS

PIECE FITS OVER A 1/2 INCH HORIZONTAL SQUARE BAR.



Section:

Toll Free (800) 527-1318

(972) 286-2368

Fax: (972) 557-4727

Security Door  
Panel Castings



ALUMINUM CASTINGS

**241** DF  
NEW



STUB OAK

HEIGHT 33 1/4 IN 84.5 CM  
WIDTH 8 1/8 IN 21.0 CM  
THICK 7/8 IN 2.2 CM  
WEIGHT 6.0 LBS 2.7 KGS

**243** DF  
NEW



NARROW OAK

HEIGHT 33 1/4 IN 84.5 CM  
WIDTH 7 5/8 IN 19.7 CM  
THICK 5/8 IN 1.9 CM  
WEIGHT 4.8 LBS 2.2 KGS

**244** DF  
NEW



RUN OAK

HEIGHT 33 1/4 IN 84.5 CM  
WIDTH 8 1/8 IN 21.0 CM  
THICK 7/8 IN 2.2 CM  
WEIGHT 6.0 LBS 2.7 KGS

**245** DF  
NEW

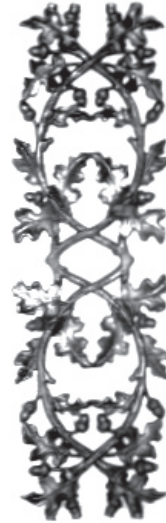

WIDE OAK

HEIGHT 33 1/4 IN 84.5 CM  
WIDTH 10 IN 25.4 CM  
THICK 7/8 IN 2.2 CM  
WEIGHT 5.2 LBS 2.4 KGS

**246** DF  
NEW



CURLY OAK

HEIGHT 33 IN 83.8 CM  
WIDTH 7 IN 17.8 CM  
THICK 7/8 IN 2.2 CM  
WEIGHT 3.6 LBS 1.6 KGS

**247** DF  
NEW



PONTALBA

HEIGHT 33 1/4 IN 84.5 CM  
WIDTH 8 1/2 IN 21.6 CM  
THICK 7/8 IN 2.2 CM  
WEIGHT 4.0 LBS 1.8 KGS

**242** DF  
NEW



PASSION FLOWER

HEIGHT 33 1/4 IN 84.5 CM  
WIDTH 11 3/4 IN 28.6 CM  
THICK 7/8 IN 2.2 CM  
WEIGHT 6.3 LBS 2.9 KGS

REVISION DATE: 12/07/94

SCALE: 1 INCH = 1 FOOT UNLESS NOTED



# Alloy Casting

## ALUMINUM CASTINGS

Toll Free (800) 527-1318

(972) 286-2368

Fax: (972) 557-4727

Section:

**Security Doors:  
Panel Castings**

**248**      **DF**  
NEW



28 INCH SHORT BIRD

HEIGHT 28 IN	71.1 CM
WIDTH 8 1/4 IN	21.0 CM
THICK 5/8 IN	1.6 CM
WEIGHT 3.5 LBS	1.6 KGS

**448**      **DF**  
NEW



28 1/4 INCH SHORT BIRD  
MOST COMMONLY USED BIRD  
IN SECURITY DOORS.

HEIGHT 28 1/4 IN	71.8 CM
WIDTH 8 IN	20.3 CM
THICK 3/4 IN	1.9 CM
WEIGHT 3.7 LBS	1.7 KGS

**1020**      **DF**  
NEW



27 1/4 INCH SHORT BIRD

HEIGHT 27 1/4 IN	69.2 CM
WIDTH 8 IN	20.3 CM
THICK 3/4 IN	1.9 CM
WEIGHT 3.6 LBS	1.6 KGS

**2487**      **DF**  
NEW



27 1/4 INCH NARROW  
SHORT BIRD

HEIGHT 27 1/4 IN	69.2 CM
WIDTH 7 IN	17.8 CM
THICK 3/4 IN	1.9 CM
WEIGHT 3.6 LBS	1.6 KGS

**249**      **DF**  
NEW



LONG BIRD

HEIGHT 33 1/4 IN	84.5 CM
WIDTH 8 1/8 IN	21.0 CM
THICK 7/8 IN	2.2 CM
WEIGHT 6.0 LBS	2.7 KGS

**640**      **DF**  
NEW



MAGNOLIA

HEIGHT 27 3/4 IN	70.5 CM
WIDTH 9 1/2 IN	24.1 CM
THICK 7/8 IN	2.2 CM
WEIGHT 4.5 LBS	1.9 KGS

**865**      **DF**  
NEW



PONTALBA

HEIGHT 33 IN	83.8 CM
WIDTH 7 3/8 IN	18.7 CM
THICK 5/8 IN	1.6 CM
WEIGHT 3.9 LBS	1.8 KGS

**1622**      **DF**  
NEW



LONG ROSE

HEIGHT 29 1/2 IN	74.9 CM
WIDTH 7 1/2 IN	19.0 CM
THICK 3/4 IN	1.9 CM
WEIGHT 3.6 LBS	1.6 KGS

REVISION DATE: 12/08/94

SCALE: 1 INCH = 1 FOOT UNLESS NOTED



Section:

Toll Free (800) 527-1318

Security Doors:  
Scroll Friezes

(972) 286-2368

Fax: (972) 557-4727



**221** 3 1/2 X 25 1/2 **DF**  
NEW

HEIGHT	3 1/2 IN	8.9 CM
WIDTH	25 1/2 IN	64.8 CM
THICK	3/4 IN	1.9 CM
WEIGHT	1.6 LBS	0.7 KGS

**456** 4 X 10 **DF**  
NEW

SHORT FRIEZE  
TO PUT IN EACH SIDE OF MAIL SLOT

HEIGHT	4 IN	10.2 CM
WIDTH	10 IN	25.4 CM
THICK	3/4 IN	1.9 CM
WEIGHT	0.6 LBS	0.3 KGS

**431** 4 X 30 1/2 **DF**  
NEW

HEIGHT	4 IN	10.2 CM
WIDTH	30 1/2 IN	77.5 CM
THICK	3/4 IN	1.9 CM
WEIGHT	2.0 LBS	0.9 KGS

**439** 4 X 31 3/8 **DF**  
NEW

HEIGHT	4 IN	10.2 CM
WIDTH	31 3/8 IN	80.0 CM
THICK	3/4 IN	1.9 CM
WEIGHT	2.2 LBS	1.0 KGS

**437** 4 X 28 1/4 **DF**  
NEW

HEIGHT	4 IN	10.2 CM
WIDTH	28 1/4 IN	71.8 CM
THICK	3/4 IN	1.9 CM
WEIGHT	2.2 LBS	1.0 KGS

**231** 4 1/8 X 30 1/2 **DF**  
NEW

HEIGHT	4 1/8 IN	10.5 CM
WIDTH	30 1/2 IN	77.5 CM
THICK	3/4 IN	1.9 CM
WEIGHT	2.0 LBS	0.9 KGS

**422** 4 1/4 X 28 1/8 **DF**  
NEW

PIECE FITS OVER A 1/2 INCH HORIZONTAL SQUARE BAR.

HEIGHT	4 1/4 IN	10.8 CM
WIDTH	28 1/8 IN	71.4 CM
THICK	1 IN	2.5 CM
WEIGHT	2.7 LBS	1.2 KGS

**233** 4 3/8 X 27 3/4 **DF**  
NEW

HEIGHT	4 3/8 IN	11.1 CM
WIDTH	27 3/4 IN	70.5 CM
THICK	7/8 IN	2.2 CM
WEIGHT	2.2 LBS	1.0 KGS

**234** 4 3/8 X 31 1/4 **DF**  
NEW

HEIGHT	4 3/8 IN	11.1 CM
WIDTH	31 1/4 IN	79.4 CM
THICK	7/8 IN	2.2 CM
WEIGHT	2.4 LBS	1.1 KGS

**238** 4 7/8 X 31 1/2 **DF**  
NEW

HEIGHT	4 7/8 IN	12.4 CM
WIDTH	31 1/2 IN	80.0 CM
THICK	3/4 IN	1.9 CM
WEIGHT	2.2 LBS	1.0 KGS

**237** 5 X 31 1/8 **DF**  
NEW

HEIGHT	5 IN	12.7 CM
WIDTH	31 1/8 IN	79.1 CM
THICK	5/8 IN	1.6 CM
WEIGHT	3.1 LBS	1.4 KGS

**232** 5 X 29 7/8 **DF**  
NEW

HEIGHT	5 IN	12.7 CM
WIDTH	29 7/8 IN	75.9 CM
THICK	3/4 IN	1.9 CM
WEIGHT	2.1 LBS	1.0 KGS

REVISION DATE: 01/19/95

SCALE: 1 INCH = 1 FOOT UNLESS NOTED



# Alloy Casting

ALUMINUM CASTINGS

Toll Free (800) 527-1318

(972) 286-2368

Fax: (972) 557-4727

Section:

Security Doors:  
Scroll Friezes

**1022** **DF**  
NEW **5 X 31 1/2**

HEIGHT	IN	FOR THE MAIL SLOT:	CM
WIDTH	IN	OUTSIDE FACE IS 3 1/4 X 10 INCHES	CM
THICK	IN	INSIDE FACE IS 2 X 8 1/2 INCHES	CM
WEIGHT	LBS		KGS

**446** **DF**  
NEW **5 1/8 X 9 7/8**

SHORT FRIEZE  
TO PUT IN EACH SIDE OF MAIL SLOT

HEIGHT	5 1/8 IN	13.0 CM
WIDTH	9 7/8 IN	25.1 CM
THICK	3/4 IN	1.9 CM
WEIGHT	0.6 LBS	0.2 KGS

**432** **DF**  
NEW **5 1/4 X 29 1/8**

HEIGHT	5 1/4 IN	13.3 CM
WIDTH	29 1/8 IN	74.0 CM
THICK	7/8 IN	2.2 CM
WEIGHT	1.8 LBS	0.8 KGS

**436** **DF**  
NEW **5 1/4 X 29 1/8**

HEIGHT	5 1/4 IN	13.3 CM
WIDTH	25 1/4 IN	74.0 CM
THICK	7/8 IN	2.2 CM
WEIGHT	1.8 LBS	0.8 KGS

**438** **DF**  
NEW **5 1/4 X 31 1/2**

HEIGHT	5 1/4 IN	13.3 CM
WIDTH	31 1/2 IN	80.0 CM
THICK	3/4 IN	1.9 CM
WEIGHT	2.2 LBS	1.0 KGS

**433** **DF**  
NEW **5 1/4 X 25 1/4**

HEIGHT	5 1/4 IN	13.3 CM
WIDTH	25 1/4 IN	80.0 CM
THICK	3/4 IN	1.9 CM
WEIGHT	2.2 LBS	1.0 KGS

**435** **DF**  
NEW **5 1/4 X 25**

HEIGHT	5 1/4 IN	13.3 CM
WIDTH	25 IN	63.5 CM
THICK	3/4 IN	1.9 CM
WEIGHT	1.9 LBS	0.8 KGS

**538** **DF**  
NEW **5 1/2 X 25 1/4**

HEIGHT	5 1/2 IN	14.0 CM
WIDTH	25 1/4 IN	80.0 CM
THICK	3/4 IN	1.9 CM
WEIGHT	2.2 LBS	1.0 KGS

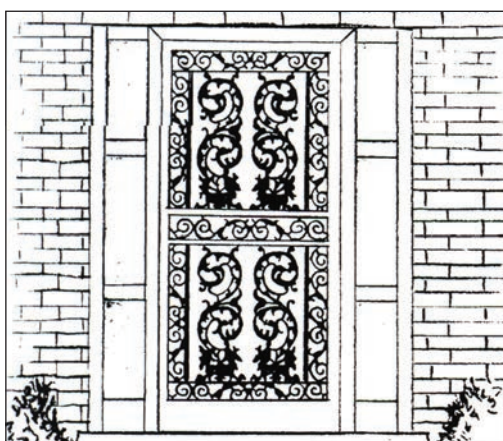

Short bird #448 and scroll frieze #231 in a very popular security door design.

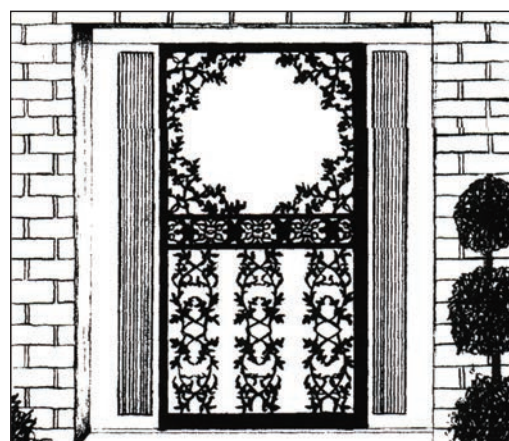

oak doo panel #245, oak corners #215 and #216, and oak frieze #236 in a common security door design.

REVISION DATE: 01/19/95

SCALE: 1 INCH = 1 FOOT UNLESS NOTED



Section:

Toll Free (800) 527-1318

(972) 286-2368

Fax: (972) 557-4727



Security Doors:  
Acorn Friezes

**426** NEW 4 X 28 5/8 **DF**  
] 1/2" [



HEIGHT	4 IN		10.2 CM
WIDTH	28 5/8 IN	PIECE FITS OVER A 1/2 INCH HORIZONTAL SQUARE BAR.	72.7 CM
THICK	1 IN		2.5 CM
WEIGHT	2.0 LBS		0.9 KGS

**455** NEW 4 X 10 **DF**



HEIGHT	4 IN	SHORT FRIEZE	10.2 CM
WIDTH	10 IN	TO PUT IN EACH SIDE OF MAIL SLOT	CM 25.4
THICK	3/4 IN		1.9 CM
WEIGHT	0.8 LBS		0.3 KGS

**463** NEW 4 1/8 X 29 3/4 **DF**



HEIGHT	4 1/8 IN		10.5 CM
WIDTH	29 3/4 IN		75.6 CM
THICK	7/8 IN		2.2 CM
WEIGHT	2.4 LBS		1.1 KGS

**235** NEW 4 3/4 X 31 5/8 **DF**



HEIGHT	4 3/4 IN		12.7 CM
WIDTH	31 5/8 IN		75.9 CM
THICK	3/4 IN		1.9 CM
WEIGHT	2.1 LBS		1.0 KGS

**236** NEW 4 7/8 X 33 1/4 **DF**



HEIGHT	4 7/8 IN		12.4 CM
WIDTH	33 1/4 IN		84.5 CM
THICK	3/4 IN		1.9 CM
WEIGHT	3.1 LBS		1.4 KGS

**464** NEW 4 7/8 X 30 1/8 **DF**



HEIGHT	4 7/8 IN		12.4 CM
WIDTH	30 1/8 IN		76.5 CM
THICK	3/4 IN		1.9 CM
WEIGHT	2.6 LBS		1.2 KGS

**1027** NEW 5 X 31 1/2 **DF**



HEIGHT	5 IN		12.7 CM
WIDTH	31 1/2 IN	FOR THE MAIL SLOT:	80.0 CM
THICK	1 IN	OUTSIDE FACE IS 3 1/4 X 10 INCHES	2.5 CM
WEIGHT	3.8 LBS	INSIDE FACE IS 2 X 8 1/2 INCHES	1.7 KGS

**445** NEW 5 X 9 7/8 **DF**



HEIGHT	5 IN	SHORT FRIEZE	12.7 CM
WIDTH	9 7/8 IN	TO PUT IN EACH SIDE OF MAIL SLOT	25.1 CM
THICK	1/2 IN		1.3 CM
WEIGHT	0.8 LBS		0.3 KGS

**239** NEW 5 1/4 X 31 1/2 **DF**



HEIGHT	5 1/4 IN		13.0 CM
WIDTH	31 1/2 IN		80.0 CM
THICK	3/4 IN		1.9 CM
WEIGHT	3.0 LBS		1.4 KGS

**539** NEW 5 1/2 X 31 3/8 **DF**



HEIGHT	5 1/2 IN		14.0 CM
WIDTH	31 3/8 IN		31.4 CM
THICK	3/4 IN		1.9 CM
WEIGHT	3.2 LBS		1.5 KGS

REVISION DATE: 01/19/95

SCALE: 1 INCH = 1 FOOT UNLESS NOTED

**12** **DF**



HEIGHT 16 5/8 IN	42.2 CM
WIDTH 8 1/4 IN	21.0 CM
THICK 7/8 IN	2.2 CM
WEIGHT 2.6 LBS	1.2 KGS

**2012** **SBO**  
OLD 12X2



HEIGHT 16 5/8 IN	42.2 CM
WIDTH 8 IN	20.3 CM
THICK 7/8 IN	2.2 CM
WEIGHT 2.1 LBS	1.0 KGS

**3012** **DF**  
OLD 12X3



SAME AS NUMBER 12 WITH HOLE IN THE LUGS.

HEIGHT 16 5/8 IN	42.2 CM
WIDTH 8 1/4 IN	21.0 CM
THICK 3/4 IN	2.2 CM
WEIGHT 2.6 LBS	1.2 KGS

**4012** **SBO**  
OLD 12X4



SAME AS NUMBER 2012 WITH HOLE IN THE LUGS.

HEIGHT 16 5/8 IN	42.2 CM
WIDTH 8 IN	20.3 CM
THICK 3/4 IN	1.9 CM
WEIGHT 2.1 LBS	1.0 KGS

**1201** **SF**  
OLD 201S1



HEIGHT 3 1/8 IN	7.9 CM
WIDTH 8 IN	20.3 CM
THICK 3/4 IN	1.9 CM
WEIGHT 0.4 LBS	0.2 KGS

**2201** **DF**  
OLD 201S2



HEIGHT 3 1/8 IN	7.9 CM
WIDTH 8 IN	20.3 CM
THICK 3/4 IN	1.9 CM
WEIGHT 0.4 LBS	0.2 KGS

**3201** **SF**  
OLD 201S3



HEIGHT 3 1/8 IN	7.9 CM
WIDTH 8 IN	20.3 CM
THICK 3/4 IN	1.9 CM
WEIGHT 0.4 LBS	0.2 KGS

**206** **SF**  
OLD 206F



NOTE: NOT TO SCALE

HEIGHT 5 1/4 IN	13.3 CM
WIDTH 23 3/4 IN	60.3 CM
THICK 1 IN	2.5 CM
WEIGHT 1.5 LBS	0.7 KGS

**200** **DF**



HEIGHT 28 IN	71.1 CM
WIDTH 11 3/8 IN	28.9 CM
THICK 7/8 IN	2.2 CM
WEIGHT 4.3 LBS	2.0 KGS

**241** **DF**  
NEW



HEIGHT 33 1/4 IN	84.5 CM
WIDTH 7 1/2 IN	19.0 CM
THICK 7/8 IN	2.2 CM
WEIGHT 4.0 LBS	1.8 KGS

**243** **DF**  
NEW



HEIGHT 33 1/4 IN	84.5 CM
WIDTH 7 3/4 IN	19.7 CM
THICK 3/4 IN	1.9 CM
WEIGHT 4.8 LBS	2.2 KGS

**245** **DF**  
NEW

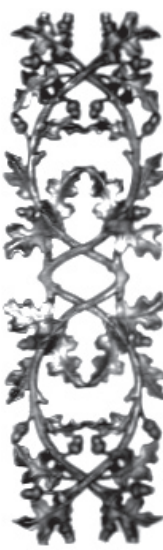

HEIGHT 33 1/4 IN	84.5 CM
WIDTH 10 IN	25.4 CM
THICK 7/8 IN	2.2 CM
WEIGHT 5.2 LBS	2.4 KGS



Section:

Toll Free (800) 527-1318

(972) 286-2368

Fax: (972) 557-4727

# Traditional Oak Castings



**210** **SF**  
OLD 210BL

HEIGHT 4 IN 10.2 CM  
WIDTH 7 1/2 IN 19.0 CM  
THICK 1/4 IN 0.6 CM  
WEIGHT 0.4 LBS 0.2 KGS

**212** **SF**  
OLD 210BR

HEIGHT 4 IN 10.2 CM  
WIDTH 7 1/2 IN 19.0 CM  
THICK 1/4 IN 0.6 CM  
WEIGHT 0.4 LBS 0.2 KGS

**215** **DF**  
OLD 215BL

HEIGHT 15 1/2 IN 39.4 CM  
WIDTH 16 1/2 IN 41.9 CM  
THICK 7/8 IN 2.2 CM  
WEIGHT 2.8 LBS 1.3 KGS

**216** **DF**  
OLD 215BR

HEIGHT 15 1/2 IN 39.4 CM  
WIDTH 16 1/2 IN 41.9 CM  
THICK 7/8 IN 2.2 CM  
WEIGHT 2.8 LBS 1.3 KGS

SET

**203** **SF**  
OLD203B

HEIGHT 12 3/4 IN 32.4 CM  
WIDTH 12 3/4 IN 32.4 CM  
THICK 7/8 IN 2.2 CM  
WEIGHT 2.4 LBS 1.1 KGS

**204** **DF**  
OLD 204BNB

HEIGHT 15 1/2 IN 39.4 CM  
WIDTH 16 1/2 IN 41.9 CM  
THICK 3/4 IN 1.9 CM  
WEIGHT 2.3 LBS 1.0 KGS

**207** **SF**  
OLD 207B

HEIGHT 15 3/4 IN 40.0 CM  
WIDTH 15 1/2 IN 39.4 CM  
THICK 7/8 IN 2.2 CM  
WEIGHT 2.4 LBS 1.1 KGS

**201** **DF**

ACORNS HOLLOW ON BACK

HEIGHT 19 IN 48.3 CM  
WIDTH 7 3/4 IN 9.7 CM  
THICK 7/8 IN 2.2 CM  
WEIGHT 2.1 LBS 1.0 KGS

**208** **DF**  
OLD 208B

HEIGHT 21 1/4 IN 54.0 CM  
WIDTH 21 1/4 IN 54.0 CM  
THICK 7/8 IN 2.2 CM  
WEIGHT 4.4 LBS 2.0 KGS

**209** **DF**  
OLD 209B

HEIGHT 23 1/2 IN 59.7 CM  
WIDTH 23 1/2 IN 59.7 CM  
THICK 7/8 IN 2.2 CM  
WEIGHT 5.0 LBS 2.3 KGS



Oak panel design #200 with corner #208 and frieze #206 as a porch enhancement.

REVISION DATE: 02/20/95

SCALE: 1 INCH = 1 FOOT UNLESS NOTED



# Alloy Casting

## ALUMINUM CASTINGS

Toll Free (800) 527-1318

(972) 286-2368

Fax: (972) 557-4727

Section:

**Big Oak Castings**

**253**

**DF**



HEIGHT	6 IN	15.2 CM
WIDTH	12 IN	30.5 CM
THICK	3/4 IN	1.9 CM
WEIGHT	1.2 LBS	0.5 KGS

**256**

**SF**

OLD 256F



HEIGHT	3 7/8 IN	9.8 CM
WIDTH	22 1/4 IN	56.5 CM
THICK	5/8 IN	1.6 CM
WEIGHT	1.6 LBS	0.7 KGS

**252**

**SBO**

OLD 252B



HEIGHT	18 1/2 IN	47.0 CM
WIDTH	19 IN	48.3 CM
THICK	3/4 IN	1.9 CM
WEIGHT	2.5 LBS	1.1 KGS

**1252**

**SBO**

OLD 252BNB



HEIGHT	18 1/2 IN	47.0 CM
WIDTH	18 1/2 IN	47.0 CM
THICK	1/2 IN	1.3 CM
WEIGHT	2.2 LBS	1.0 KGS

**1251**

**SBO**

OLD 251S3



HEIGHT	11 1/4 IN	28.6 CM
WIDTH	8 IN	20.3 CM
THICK	7/8 IN	2.2 CM
WEIGHT	1.0 LBS	0.4 KGS

**251**

**SBO**



HEIGHT	20 IN	50.8 CM
WIDTH	7 1/2 IN	19.0 CM
THICK	7/8 IN	2.2 CM
WEIGHT	2.0 LBS	0.5 KGS

**211**

**DF**

OLD 211F



HEIGHT	7 IN	17.8 CM
WIDTH	13 1/4 IN	33.7 CM
THICK	3/4 IN	1.9 CM
WEIGHT	1.2 LBS	0.6 KGS

**250**

**SBO**

NOT TO SCALE



HEIGHT	26 5/8 IN	67.6 CM
WIDTH	12 1/4 IN	31.1 CM
THICK	7/8 IN	2.2 CM
WEIGHT	5.2 LBS	2.4 KGS

REVISION DATE: 12/08/94

SCALE: 1 INCH = 1 FOOT UNLESS NOTED

**Section:**  
**Oak**  
**Castings**

Toll Free (800) 527-1318

(972) 286-2368

Fax: (972) 557-4727



**ALUMINUM CASTINGS**

**282** **DF**

OLD 282B



HEIGHT 14 3/4 IN 37.5 CM  
WIDTH 15 IN 38.1 CM  
THICK 3/4 IN 1.9 CM  
WEIGHT 2.0 LBS 0.9 KGS

**283** **DF**

OLD 283B



HEIGHT 9 1/4 IN 23.5 CM  
WIDTH 15 1/4 IN 38.7 CM  
THICK 3/4 IN 1.9 CM  
WEIGHT 1.8 LBS 0.8 KGS

**264** **DF**

OLD 264BL

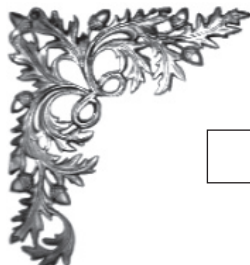

HEIGHT 16 3/4 IN 42.5 CM  
WIDTH 15 3/4 IN 40.0 CM  
THICK 7/8 IN 2.2 CM  
WEIGHT 2.2 LBS 1.0 KGS

**265** **DF**

OLD 264BR



HEIGHT 16 3/4 IN 42.5 CM  
WIDTH 15 3/4 IN 40.0 CM  
THICK 7/8 IN 2.2 CM  
WEIGHT 2.2 LBS 1.0 KGS

SET

**280** **DF**



HEIGHT 22 5/8 IN 57.5 CM  
WIDTH 8 1/8 IN 20.6 CM  
THICK 3/4 IN 1.9 CM  
WEIGHT 2.6 LBS 1.2 KGS

**244** **DF**



HEIGHT 33 1/4 IN 84.5 CM  
WIDTH 7 5/8 IN 19.4 CM  
THICK 5/8 IN 1.6 CM  
WEIGHT 4.5 LBS 2.0 KGS

**270** **DF**



HEIGHT 26 3/4 IN 67.9 CM  
WIDTH 9 1/2 IN 24.1 CM  
THICK 7/8 IN 2.2 CM  
WEIGHT 3.7 LBS 1.7 KGS

**271** **DF**

OLD 271BNB

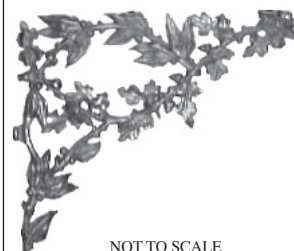

NOT TO SCALE

HEIGHT 17 3/4 IN 45.1 CM  
WIDTH 21 IN 53.3 CM  
THICK 7/8 IN 2.2 CM  
WEIGHT 3.8 LBS 1.7 KGS

**285**

OLD 285F

**DF**



HEIGHT 9 1/2 IN 24.1 CM  
WIDTH 15 1/4 IN 38.7 CM  
THICK 7/8 IN 2.2 CM  
WEIGHT 1.4 LBS 0.6 KGS





**ALUMINUM CASTINGS**

Toll Free (800) 527-1318

(972) 286-2368

Fax: (972) 557-4727

Section:

**Birds Of Paradise**

**248**      **DF**  
NEW

HEIGHT 28 IN      71.1 CM  
WIDTH 8 1/4 IN      21.0 CM  
THICK 5/8 IN      1.6 CM  
WEIGHT 3.5 LBS      1.6 KGS

**249**      **DF**  
NEW

LONG BIRD

HEIGHT 33 1/4 IN      84.5 CM  
WIDTH 8 1/8 IN      21.0 CM  
THICK 7/8 IN      2.2 CM  
WEIGHT 6.0 LBS      2.7 KGS

**400**      **DF**

HEIGHT 26 3/8 IN      67.0 CM  
WIDTH 9 3/8 IN      23.8 CM  
THICK 7/8 IN      2.2 CM  
WEIGHT 6.2 LBS      2.8 KGS

**401**      **DF**

HEIGHT 23 1/4 IN      59.1 CM  
WIDTH 8 3/4 IN      22.2 CM  
THICK 7/8 IN      2.2 CM  
WEIGHT 4.4 LBS      2.0 KGS

**448**      **DF**

28 1/4 INCH SHORT BIRD

MOST COMMONLY USED  
SECURITY DOOR CASTING.

HEIGHT 28 1/4 IN      71.8 CM  
WIDTH 8 IN      20.3 CM  
THICK 3/4 IN      1.9 CM  
WEIGHT 3.7 LBS      1.7 KGS

**2487**      **DF**  
NEW

27 14 INCH X 7 INCH  
SHORTER-NARROW BIRD

HEIGHT 27 1/4 IN      69.2 CM  
WIDTH 7 IN      17.8 CM  
THICK 3/4 IN      1.9 CM  
WEIGHT 3.2 LBS      1.5 KGS

**1020**      **DF**  
NEW

27 1/4 INCH SHORTER BIRD

HEIGHT 27 1/4 IN      69.2 CM  
WIDTH 8 IN      20.3 CM  
THICK 3/4 IN      1.9 CM  
WEIGHT 3.4 LBS      1.5 KGS

**404**      **DF**

HEIGHT 22 IN      55.9 CM  
WIDTH 8 1/2 IN      21.6 CM  
THICK 7/8 IN      2.2 CM  
WEIGHT 5.1 LBS      2.3 KGS

REVISION DATE: 03/28/95

SCALE: 1 INCH = 1 FOOT UNLESS NOTED

Section:  
Birds Of Paradise

Toll Free (800) 527-1318  
(972) 286-2368  
Fax: (972) 557-4727



ALUMINUM CASTINGS

**31** **DF**  
]1/2"["



PICKET CASTING

HEIGHT 14 1/4 IN	33.2 CM
WIDTH 7 7/8 IN	20.0 CM
THICK 3/4 IN	1.9 CM
WEIGHT 1.6 LBS	0.7 KGS

**415** **DF**  
NEW

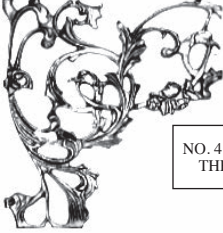

NO. 415 AND NO. 416 ARE THE SAME CASTING.

HEIGHT 15 1/2 IN	39.4 CM
WIDTH 16 1/4 IN	41.3 CM
THICK 1 IN	2.5 CM
WEIGHT 4.2 LBS	1.9 KGS

**416** **DF**  
NEW



HEIGHT 15 1/2 IN	39.4 CM
WIDTH 16 1/4 IN	41.3 CM
THICK 1 IN	2.5 CM
WEIGHT 4.2 LBS	1.9 KGS

**403** **DF**



HEIGHT 16 3/4 IN	40.6 CM
WIDTH 8 3/4 IN	22.2 CM
THICK 1 IN	2.5 CM
WEIGHT 3.5 LBS	1.6 KGS

**408** **DF**  
NEW

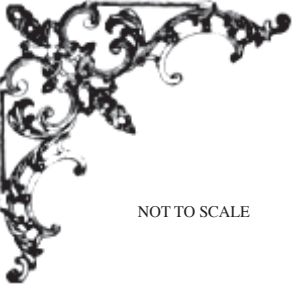

NOT TO SCALE

HEIGHT 21 1/4 IN	54.0 CM
WIDTH 21 3/8 IN	54.3 CM
THICK 1 IN	2.5 CM
WEIGHT 4.6 LBS	2.1 KGS

**405** **DF**



HEIGHT 22 1/2 IN	55.9 CM
WIDTH 9 IN	22.9 CM
THICK 1 1/8 IN	2.9 CM
WEIGHT 5.2 LBS	2.4 KGS

**409** **DF**  
NEW



HEIGHT 21 IN	53.3 CM
WIDTH 8 1/2 IN	21.6 CM
THICK 1 IN	5.4 CM
WEIGHT 3.2 LBS	1.5 KGS

**406** **DF**  
NEW



NOT TO SCALE

HEIGHT 6 1/2 IN	16.5 CM
WIDTH 21 IN	53.3 CM
THICK 1 IN	2.5 CM
WEIGHT 2.6 LBS	1.2 KGS

**402** **DF**  
OLD 402B



HEIGHT 17 3/4 IN	45.1 CM
WIDTH 21 1/8 IN	53.7 CM
THICK 3/4 IN	1.9 CM
WEIGHT 6.0 LBS	1.6 KGS

**410** **DF**  
NEW



HEIGHT 10 1/2 IN	26.7 CM
WIDTH 18 1/2 IN	47.0 CM
THICK 1 IN	2.5 CM
WEIGHT 2.4 LBS	1.1 KGS

**407** **DF**  
NEW



HEIGHT 17 3/4 IN	45.1 CM
WIDTH 21 1/2 IN	54.6 CM
THICK 1 IN	2.5 CM
WEIGHT 5.8 LBS	2.6 KGS

REVISION DATE: 01/30/95

SCALE: 1 INCH = 1 FOOT UNLESS NOTED

## ALUMINUM CASTINGS

**620 DF**



HEIGHT	23 3/4 IN	60.3 CM
WIDTH	8 1/4 IN	21.0 CM
THICK	3/4 IN	1.9 CM
WEIGHT	2.8 LBS	1.3 KGS

**1622 DF**  
NEW



HEIGHT	29 1/2 IN	74.9 CM
WIDTH	7 1/2 IN	19.0 CM
THICK	3/4 IN	1.9 CM
WEIGHT	3.6 LBS	1.6 KGS

**622 DF**



HEIGHT	22 IN	55.9 CM
WIDTH	7 1/2 IN	19.0 CM
THICK	3/4 IN	1.9 CM
WEIGHT	2.5 LBS	1.1 KGS

**621 DF**



HEIGHT	27 3/4 IN	70.5 CM
WIDTH	11 1/4 IN	28.6 CM
THICK	7/8 IN	2.2 CM
WEIGHT	4.2 LBS	1.9 KGS

**610 SBO**



HEIGHT	27 1/4 IN	69.2 CM
WIDTH	12 IN	30.5 CM
THICK	1 IN	2.5 CM
WEIGHT	6.6 LBS	3.0 KGS

**611 DF**  
OLD 611P



HEIGHT	27 7/8 IN	70.8 CM
WIDTH	6 3/4 IN	17.1 CM
THICK	1 IN	2.5 CM
WEIGHT	2.9 LBS	1.3 KGS

**600 DF**



HEIGHT	23 1/4 IN	59.1 CM
WIDTH	9 IN	22.9 CM
THICK	1 IN	2.5 CM
WEIGHT	3.8 LBS	1.7 KGS

**619 DF**  
NEW



HEIGHT	26 3/4 IN	67.9 CM
WIDTH	10 3/4 IN	27.3 CM
THICK	3/4 IN	1.9 CM
WEIGHT	3.9 LBS	1.8 KGS



Section:  
Roses

Toll Free (800) 527-1318

(972) 286-2368

Fax: (972) 557-4727



ALUMINUM CASTINGS

**23** **DF**  
]1/2"["

HEIGHT 16 3/4 IN 42.5 CM  
WIDTH 7 1/2 IN 19.0 CM  
THICK 3/4 IN 1.9 CM  
WEIGHT 1.6 LBS 0.7 KGS

**1621** **DF**  
OLD 621B

HEIGHT 15 1/2 IN 39.4 CM  
WIDTH 15 1/2 IN 39.4 CM  
THICK 7/8 IN 2.2 CM  
WEIGHT 2.1 LBS 1.0 KGS

**1624** **DF**  
OLD 624M

HEIGHT 7 3/4 IN 19.7 CM  
WIDTH 7 3/4 IN 19.7 CM  
THICK 3/4 IN 2.2 CM  
WEIGHT 1.2 LBS 0.6 KGS

**626** **DF**  
OLD 626B

HEIGHT 10 IN 25.4 CM  
WIDTH 15 1/8 IN 38.7 CM  
THICK 7/8 IN 2.2 CM  
WEIGHT 1.6 LBS 0.7 KGS

**629** **DF**

HEIGHT 14 1/4 IN 36.2 CM  
WIDTH 8 3/4 IN 22.2 CM  
THICK 3/4 IN 1.9 CM  
WEIGHT 1.9 LBS 0.9 KGS

**628** **DF**

NOTE: SCALE IS 1 INCH = 6 INCHES

HEIGHT 1 3/4 IN 4.4 CM  
WIDTH 7 IN 17.8 CM  
THICK 5/8 IN 1.6 CM  
WEIGHT 0.2 LBS 0.1 KGS

**631** **DF**  
NEW

NOTE: SCALE IS 1 INCH = 6 INCHES

HEIGHT 1 1/2 IN 3.8 CM  
WIDTH 5 IN 12.7 CM  
THICK 7/8 IN 2.2 CM  
WEIGHT 0.3 LBS 0.1 KGS

**623** **DF**  
OLD 623F

HEIGHT 4 1/2 IN 11.4 CM  
WIDTH 21 IN 53.3 CM  
THICK 1 IN 2.5 CM  
WEIGHT 1.6 LBS 0.7 KGS

**1620** **DF**  
OLD 620F

HEIGHT 4 3/4 IN 12.1 CM  
WIDTH 22 1/4 IN 56.5 CM  
THICK 7/8 IN 2.2 CM  
WEIGHT 1.5 LBS 0.7 KGS

**625** **DF**  
OLD 625BNB

HEIGHT 9 1/4 IN 19.7 CM  
WIDTH 18 1/4 IN 46.4 CM  
THICK 7/8 IN 2.2 CM  
WEIGHT 1.5 LBS 0.7 KGS

**603** **DF**  
OLD 603F

HEIGHT 5 1/4 IN 13.3 CM  
WIDTH 26 IN 66.0 CM  
THICK 1 1/2 IN 3.8 CM  
WEIGHT 3.5 LBS 1.6 KGS

REVISION DATE: 12/20/94

SCALE: 1 INCH = 1 FOOT UNLESS NOTED



**ALUMINUM CASTINGS**

Toll Free (800) 527-1318

(972) 286-2368

Fax: (972) 557-4727

Section:

Roses

**624** **DF**  
OLD 624BNB

HEIGHT	21 IN	53.3 CM
WIDTH	21 IN	53.3 CM
THICK	7/8 IN	2.2 CM
WEIGHT	3.4 LBS	1.5 KGS

**627** **DF**  
OLD627B

HEIGHT	23 IN	58.4 CM
WIDTH	23 IN	58.4 CM
THICK	3/4 IN	1.9 CM
WEIGHT	3.3 LBS	1.5 KGS

**601** **DF**  
OLD 601BNB

HEIGHT	22 IN	55.9 CM
WIDTH	22 IN	55.9 CM
THICK	1 1/4 IN	3.2 CM
WEIGHT	6.8 LBS	3.1 KGS

**602** **DF**  
NEW

HEIGHT	20 1/2 IN	52.1 CM
WIDTH	20 3/4 IN	52.7 CM
THICK	1 1/4 IN	3.2 CM
WEIGHT	7.9 LBS	3.6 KGS

REVISION DATE: 01/09/95

SCALE: 1 INCH = 1 FOOT UNLESS NOTED

**Section:**  
**Grapes**

**Toll Free (800) 527-1318**  
**(972) 286-2368**  
**Fax: (972) 557-4727**



**2300**      **DF**  
OLD 300M

HEIGHT 7 1/2 IN      19.0 CM  
WIDTH 7 1/2 IN      19.0 CM  
THICK 5/8 IN      1.6 CM  
WEIGHT 1.1 LBS      0.5 KGS

**1300**      **DF**  
OLD 300BNB

HEIGHT 11 1/2 IN      29.2 CM  
WIDTH 15 3/8 IN      39.0 CM  
THICK 5/8 IN      1.6 CM  
WEIGHT 1.8 LBS      0.8 KGS

**308**      **DF**  
NEW

NOTE: NOT TO SCALE

HEIGHT 12 IN      20.3 CM  
WIDTH 23 1/2 IN      60.0 CM  
THICK 1 IN      2.5 CM  
WEIGHT 3.0 LBS      0.6 KGS

**1303**      **DF**  
NEW

HEIGHT 18 IN      45.7 CM  
WIDTH 18 1/2 IN      47.0 CM  
THICK 7/8 IN      2.2 CM  
WEIGHT LBS      1.3 KGS

**315**      **DF**  
NEW

HEIGHT 13 3/4 IN      34.9 CM  
WIDTH 16 1/2 IN      41.9 CM  
THICK 3/4 IN      1.9 CM  
WEIGHT 2.4 LBS      1.1 KGS

**321**      **DF**

HEIGHT 21 3/4 IN      56.5 CM  
WIDTH 8 IN      23.8 CM  
THICK 1 IN      2.5 CM  
WEIGHT 4.9 LBS      2.2 KGS

**21**      **DF**  
] 1/2" [

1/2" PICKET

HEIGHT 16 1/4 IN      41.3 CM  
WIDTH 7 3/8 IN      18.7 CM  
THICK 3/4 IN      1.9 CM  
WEIGHT 1.9 LBS      1.6 KGS

**304**      **DF**  
OLD 304B

NOT TO SCALE

HEIGHT 20 5/8 IN      52.4 CM  
WIDTH 21 IN      53.3 CM  
THICK 7/8 IN      2.2 CM  
WEIGHT 5.9 LBS      2.7 KGS

**302**      **DF**  
OLD 302B

HEIGHT 10 5/8 IN      27.0 CM  
WIDTH 20 IN      50.8 CM  
THICK 3/4 IN      1.9 CM  
WEIGHT 2.6 LBS      1.2 KGS

**306**      **DF**  
OLD 306F

HEIGHT 5 IN      12.7 CM  
WIDTH 20 1/8 IN      51.1 CM  
THICK 3/4 IN      1.9 CM  
WEIGHT 2.1 LBS      0.9 KGS

**307**      **DF**  
OLD 307F

HEIGHT 4 1/2 IN      11.4 CM  
WIDTH 23 1/4 IN      59.1 CM  
THICK 3/4 IN      1.9 CM  
WEIGHT 2.0 LBS      0.9 KGS

**316**      **DF**  
NEW

HEIGHT 4 IN      10.2 CM  
WIDTH 16 1/2 IN      41.9 CM  
THICK 5/8 IN      1.6 CM  
WEIGHT 1.0 LBS      0.5 KGS

REVISION DATE: 01/30/95

SCALE: 1 INCH = 1 FOOT UNLESS NOTED





**ALUMINUM CASTINGS**

Toll Free (800) 527-1318

(972) 286-2368

Fax: (972) 557-4727

Section:

**Grapes**

**299**      **DF**  
NEW

HEIGHT 24 IN      61.0 CM  
WIDTH 8 IN      20.3 CM  
THICK 5/8 IN      1.6 CM  
WEIGHT 3.3 LBS      1.5 KGS

**300**      **DF**

HEIGHT 29 1/4 IN      74.3 CM  
WIDTH 7 7/8 IN      20.0 CM  
THICK 5/8 IN      1.6 CM  
WEIGHT 4.0 LBS      1.7 KGS

**301**      **DF**

HEIGHT 25 3/8 IN      63.6 CM  
WIDTH 8 3/4 IN      22.2 CM  
THICK 7/8 IN      2.2 CM  
WEIGHT 4.5 LBS      2.0 KGS

**3300**      **DF**  
OLD 300S

HEIGHT 21 1/4 IN      54.0 CM  
WIDTH 7 1/2 IN      19.0 CM  
THICK 3/4 IN      1.9 CM  
WEIGHT 2.9 LBS      1.3 KGS

**309**      **DF**

HEIGHT 20 3/8 IN      51.8 CM  
WIDTH 7 IN      17.8 CM  
THICK 1/2 IN      1.3 CM  
WEIGHT 2.2 LBS      1.0 KGS

**310**      **DF**

HEIGHT 24 5/8 IN      62.6 CM  
WIDTH 6 1/2 IN      32.4 CM  
THICK 3/4 IN      3.2 CM  
WEIGHT 4.1 LBS      1.9 KGS

**298**      **DF**  
NEW

HEIGHT 25 7/8 IN      65.7 CM  
WIDTH 12 5/8 IN      32.1 CM  
THICK 1 IN      2.5 CM  
WEIGHT 4.9 LBS      2.2 KGS

**312**      **DF**  
NEW

HEIGHT 26 1/2 IN      67.3 CM  
WIDTH 10 IN      25.4 CM  
THICK 3/4 IN      1.9 CM  
WEIGHT 2.4 LBS      1.1 KGS

REVISION DATE: 12/21/94

SCALE: 1 INCH = 1 FOOT UNLESS NOTED

Section:  
Grapes

Toll Free (800) 527-1318  
(972) 286-2368  
Fax: (972) 557-4727



**557**  
NEW

**DF**



HEIGHT	19 1/4 IN	48.9 CM
WIDTH	11 1/4 IN	28.6 CM
THICK	3/4 IN	1.9 CM
WEIGHT	3.1 LBS	1.4 KGS

**314**  
NEW

**DF**

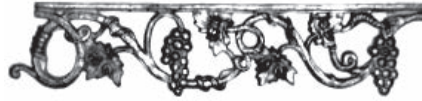

HEIGHT	6 IN	15.2 CM
WIDTH	27 IN	68.6 CM
THICK	7/8 IN	2.2 CM
WEIGHT	3.9 LBS	1.8 KGS

HEIGHT	6 IN	15.2 CM
WIDTH	27 IN	68.6 CM
THICK	7/8 IN	2.2 CM
WEIGHT	3.9 LBS	1.8 KGS

**105** **SF**  
OLD 105B



HEIGHT	20 3/4 IN	52.7 CM
WIDTH	20 3/4 IN	52.7 CM
THICK	1 IN	2.5 CM
WEIGHT	4.0 LBS	1.8 KGS

**2105** **SF**  
OLD 105BNB



HEIGHT	19 3/4 IN	50.2 CM
WIDTH	19 3/4 IN	50.2 CM
THICK	1 IN	2.5 CM
WEIGHT	2.8 LBS	1.2 KGS

**107** **SBO**  
OLD 107BSF

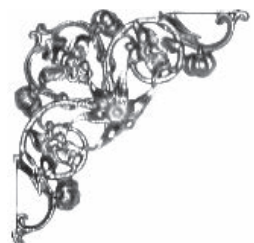

HEIGHT	15 IN	38.1 CM
WIDTH	15 IN	38.1 CM
THICK	3/4 IN	1.9 CM
WEIGHT	2.0 LBS	0.9 KGS

**242** **DF**



SIZE TO FIT  
SECURITY DOORS

HEIGHT	33 1/4 IN	84.5 CM
WIDTH	11 1/4 IN	28.6 CM
THICK	7/8 IN	2.2 CM
WEIGHT	6.3 LBS	2.9 KGS

**100** **DF**



HEIGHT	28 1/2 IN	72.4 CM
WIDTH	12 3/8 IN	31.4 CM
THICK	7/8 IN	2.2 CM
WEIGHT	4.8 LBS	2.2 KGS

**3105** **DF**  
OLD 105BS

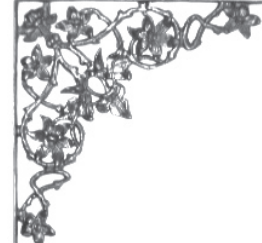

HEIGHT	16 1/2 IN	41.9 CM
WIDTH	16 1/2 IN	41.9 CM
THICK	7/8 IN	2.2 CM
WEIGHT	2.5 LBS	1.1 KGS

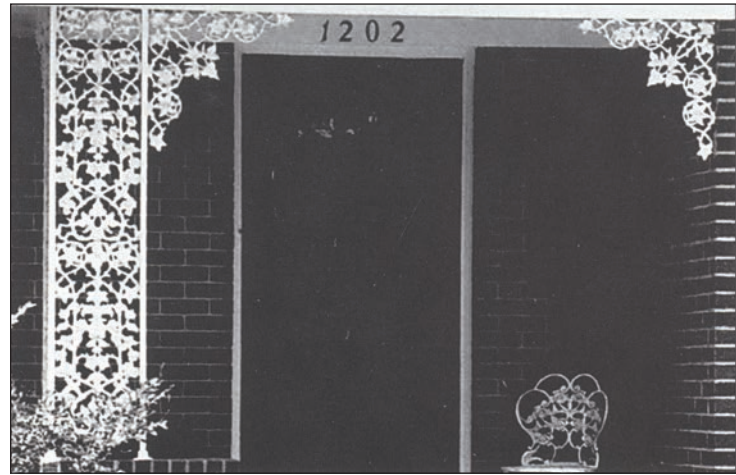

Passion flower panel #100 and corner #105 as porch columns.



Section:

Toll Free (800) 527-1318

(972) 286-2368

Fax: (972) 557-4727



ALUMINUM CASTINGS

Passion Flower

**109**      **DF**



HEIGHT	18 1/4 IN	46.4 CM
WIDTH	7 3/4 IN	19.7 CM
THICK	7/8 IN	2.2 CM
WEIGHT	2.0 LBS	0.9 KGS

**101**      **DF**



HEIGHT	18 5/8 IN	47.3 CM
WIDTH	8 1/2 IN	14.0 CM
THICK	7/8 IN	2.2 CM
WEIGHT	2.1 LBS	1.0 KGS

**3101**      **DF**

OLD 101S



HEIGHT	6 3/4 IN	17.1 CM
WIDTH	8 3/4 IN	22.2 CM
THICK	5/8 IN	1.6 CM
WEIGHT	1.0 LBS	0.4 KGS

**1101**      **DF**

OLD 101F



HEIGHT	4 IN	10.1 CM
WIDTH	18 1/2 IN	47.0 CM
THICK	7/8 IN	2.2 CM
WEIGHT	1.1 LBS	0.5 KGS

**102**      **DF**

OLD 102F



HEIGHT	4 3/4 IN	12.1 CM
WIDTH	19 IN	48.3 CM
THICK	3/4 IN	1.9 CM
WEIGHT	1.8 LBS	0.8 KGS

**104**      **DF**

OLD 104F



HEIGHT	7 1/2 IN	19.0 CM
WIDTH	24 IN	61.0 CM
THICK	3/4 IN	1.9 CM
WEIGHT	3.2 LBS	1.1 KGS

**1102**      **DF**

OLD 102FNB



HEIGHT	4 1/2 IN	11.4 CM
WIDTH	18 7/8 IN	47.9 CM
THICK	5/8 IN	1.6 CM
WEIGHT	1.6 LBS	0.6 KGS

**108**      **DF**

OLD 108F



HEIGHT	5 1/4 IN	13.3 CM
WIDTH	15 5/8 IN	39.7 CM
THICK	7/8 IN	2.2 CM
WEIGHT	1.1 LBS	0.5 KGS

REVISION DATE: 12/21/94

SCALE: 1 INCH = 1 FOOT UNLESS NOTED



# Alloy Casting

## ALUMINUM CASTINGS

Toll Free (800) 527-1318

(972) 286-2368

Fax: (972) 557-4727

Section:

## Greek Key Castings

**757**      **DF**  
OLD 757F

NOT TO SCALE

HEIGHT 4 IN	10.2 CM
WIDTH 23 1/4 IN	59.1 CM
THICK 7/8 IN	2.2 CM
WEIGHT 1.7 LBS	0.8 KGS

**751**      **DF**  
OLD 751B

HEIGHT 16 1/4 IN	41.3 CM
WIDTH 16 1/4 IN	41.3 CM
THICK 1 IN	2.5 CM
WEIGHT 2.9 LBS	1.3 KGS

**755**      **DF**

HEIGHT 27 3/4 IN	55.9 CM
WIDTH 10 7/8 IN	27.6 CM
THICK 5/8 IN	1.6 CM
WEIGHT 4.0 LBS	1.8 KGS

**756**      **DF**  
OLD 756B

HEIGHT 18 IN	45.7 CM
WIDTH 18 IN	45.7 CM
THICK 7/8 IN	2.2 CM
WEIGHT 2.8 LBS	1.2 KGS

**760**      **DF**

HEIGHT 16 5/8 IN	42.2 CM
WIDTH 10 1/8 IN	25.7 CM
THICK 5/8 IN	1.6 CM
WEIGHT 2.0 LBS	0.9 KGS

**761**      **SF**

HEIGHT 20 3/4 IN	52.7 CM
WIDTH 8 1/8 IN	29.5 CM
THICK 1/2 IN	1.6 CM
WEIGHT 2.0 LBS	0.9 KGS

**762**      **DF**

HEIGHT 9 IN	22.9 CM
WIDTH 11 5/8 IN	29.5 CM
THICK 5/8 IN	1.6 CM
WEIGHT 0.8 LBS	0.4 KGS

**763**      **SF**

HEIGHT 14 3/4 IN	37.5 CM
WIDTH 5 IN	12.7 CM
THICK 5/8 IN	1.6 CM
WEIGHT 1.8 LBS	0.8 KGS

**764**      **DF**

HEIGHT 15 1/8 IN	38.4 CM
WIDTH 3 1/8 IN	7.9 CM
THICK 1/2 IN	1.3 CM
WEIGHT 0.8 LBS	0.4 KGS

**765**      **DF**  
NEW

HEIGHT 12 5/8 IN	32.4 CM
WIDTH 3 IN	8.9 CM
THICK 1/2 IN	1.3 CM
WEIGHT 0.3 LBS	0.1 KGS

**1765**      **DF**  
NEW

HEIGHT 12 5/8 IN	32.4 CM
WIDTH 3 IN	8.9 CM
THICK 1/2 IN	1.3 CM
WEIGHT 0.3 LBS	0.1 KGS

**766**      **DF**  
NEW

HEIGHT 17 IN	43.2 CM
WIDTH 4 IN	10.2 CM
THICK 1/4 IN	0.6 CM
WEIGHT 1.6 LBS	0.3 KGS

REVISION DATE: 01/19/95

NOTE: SEE NUMBER 750 ON PAGE 34.

SCALE: 1 INCH = 1 FOOT UNLESS NOTED

Section:

Toll Free (800) 527-1318

**Greek Key Castings**

(972) 286-2368

Fax: (972) 557-4727



**ALUMINUM CASTINGS**

**750 SBO**



GREEK KEY

HEIGHT	28	IN	71.1	CM
WIDTH	11	IN	27.9	CM
THICK	1	IN	2.5	CM
WEIGHT	5.0	LBS	2.3	KGS

**752 DF**  
NEW



HEIGHT	9	IN	22.9	CM
WIDTH	5 1/8	IN	11.7	CM
THICK	1/2	IN	1.3	CM
WEIGHT	0.6	LBS	0.3	KGS

**759 DF**  
NEW



HEIGHT	13 1/4	IN	33.7	CM
WIDTH	5 1/8	IN	15.2	CM
THICK	1/2	IN	1.3	CM
WEIGHT	1.3	LBS	0.6	KGS

**767 DF**  
NEW



HEIGHT	24 1/4	IN	61.6	CM
WIDTH	10 1/2	IN	26.7	CM
THICK	5/8	IN	1.6	CM
WEIGHT	4.7	LBS	2.1	KGS

REVISION DATE: 01/19/95

SCALE: 1 INCH = 1 FOOT UNLESS NOTED





# Alloy Casting

## ALUMINUM CASTINGS



Toll Free (800) 527-1318



(972) 286-2368

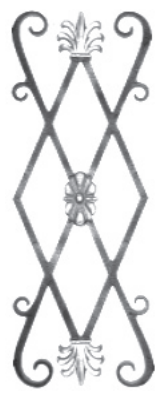

Fax: (972) 557-4727

Section:

## Anthemion Crown Castings

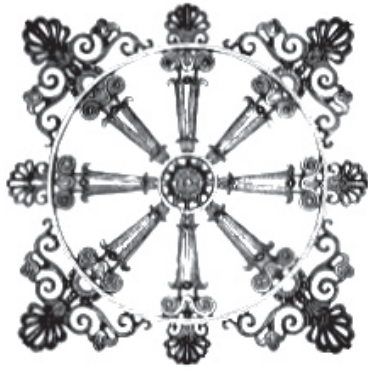
<p><b>960</b>      <b>DF</b></p>  <p>HEIGHT 26 3/4 IN      67.9 CM          WIDTH 10 IN      25.4 CM          THICK 5/8 IN      1.6 CM          WEIGHT 2.3 LBS      1.0 KGS</p>	<p><b>961</b>      <b>DF</b></p>  <p>HEIGHT 23 1/2 IN      59.7 CM          WIDTH 8 5/8 IN      21.9 CM          THICK 5/8 IN      1.6 CM          WEIGHT 3.2 LBS      1.5 KGS</p>	<p><b>7770</b>      <b>DF</b> NEW</p>  <p>HEIGHT 34 3/4 IN      88.3 CM          WIDTH 5 3/4 IN      14.6 CM          THICK 3/4 IN      1.9 CM          WEIGHT 4.0 LBS      1.8 KGS</p>	<p><b>831</b>      <b>SBO</b></p>  <p>HEIGHT 23 IN      58.4 CM          WIDTH 3 3/4 IN      9.5 CM          THICK 1 IN      2.5 CM          WEIGHT 2.0 LBS      0.9 KGS</p>
--	---	---	---

<p><b>899</b>      <b>SBO</b> NEW</p>  <p>HEIGHT 10 IN      25.4 CM          WIDTH 21 IN      53.3 CM          THICK 5/8 IN      1.6 CM          WEIGHT 2.3 LBS      1.1 KGS</p>	<p><b>890</b>      <b>SBO</b></p>  <p>DISCONTINUED SEE NUMBER 899</p> <p>HEIGHT 10 5/8 IN      27.0 CM          WIDTH 22 1/2 IN      57.2 CM          THICK 3/4 IN      1.9 CM          WEIGHT 3.0 LBS      1.4 KGS</p>	<p><b>830</b>      <b>SBO</b></p>  <p>HEIGHT 22 1/2 IN      28.4 CM          WIDTH 22 1/2 IN      58.4 CM          THICK 1 IN      2.5 CM          WEIGHT 8.5 LBS      3.8 KGS</p>
---	---	---

<p><b>888</b>      <b>DF</b> NEW</p>  <p>HEIGHT 6 IN      15.2 CM          WIDTH 18 1/4 IN      46.4 CM          THICK 3/4 IN      1.9 CM          WEIGHT 1.7 LBS      0.8 KGS</p>	<p><b>9785</b>      <b>FB</b> OLD 9265</p>  <p>HEIGHT 5 1/4 IN      13.3 CM          WIDTH 6 1/4 IN      15.9 CM          THICK 5/8 IN      1.6 CM          WEIGHT 0.9 LBS      0.4 KGS</p>
---	--

REVISION DATE: 01/19/95

SCALE: 1 INCH = 1 FOOT UNLESS NOTED

Section:

Toll Free (800) 527-1318

(972) 286-2368

Fax: (972) 557-4727



ALUMINUM CASTINGS

**Anthemion Crown Castings**

**1960**      **DF**  
OLD 960B

HEIGHT 15	IN	38.1	CM
WIDTH 15	IN	38.1	CM
THICK 3/4	IN	1.9	CM
WEIGHT 1.8	LBS	0.8	KGS

**889**      **DF**  
NEW

HEIGHT 8	IN	20.3	CM
WIDTH 8 1/2	IN	21.6	CM
THICK 1 1/8	IN	2.9	CM
WEIGHT 2.3	LBS	1.1	KGS

**891**      **DF**

HEIGHT 20 1/2	IN	52.1	CM
WIDTH 13 3/4	IN	34.9	CM
THICK 3/4	IN	1.9	CM
WEIGHT 5.2	LBS	2.4	KGS

**832**      **FB**

← BASE 3 1/4 W

HEIGHT 22	IN	50.5	CM
WIDTH 5 1/2	IN	6.4	CM
THICK 1	IN	2.5	CM
WEIGHT 2.2	LBS	1.0	KGS

**896**      **DF**  
NEW

HEIGHT 21 3/4	IN	55.2	CM
WIDTH 19 5/8	IN	49.8	CM
THICK 1 1/4	IN	3.2	CM
WEIGHT 9.5	LBS	4.3	KGS

REVISION DATE: 12/21/94

SCALE: 1 INCH = 1 FOOT UNLESS NOTED



# Alloy Casting

ALUMINUM CASTINGS











Toll Free (800) 527-1318

(972) 286-2368

Fax: (972) 557-4727

Section:

Victorian  
Castings

<p><b>983</b>      <b>DF</b> NEW</p>  <p>HEIGHT 30 IN      82.2 CM WIDTH 8 IN      26.7 CM THICK 1 1/2 IN      3.8 CM WEIGHT 5.2 LBS      2.7 KGS</p>	<p><b>885</b>      <b>SF</b></p>  <p>HEIGHT 27 3/8 IN      69.5 CM WIDTH 9 5/8 IN      24.4 CM THICK 5/8 IN      1.6 CM WEIGHT 2.2 LBS      1.0 KGS</p>	<p><b>886</b>      <b>DF</b></p>  <p>HEIGHT 27 3/8 IN      69.5 CM WIDTH 9 5/8 IN      24.4 CM THICK 3/4 IN      1.9 CM WEIGHT 4.8 LBS      2.2 KGS</p>	<p><b>920</b>      <b>SBO</b></p>  <p>HEIGHT 30 1/4 IN      78.8 CM WIDTH 9 5/8 IN      24.4 CM THICK 1 1/8 IN      2.9 CM WEIGHT 4.2 LBS      1.7 KGS</p>
<p><b>822</b>      <b>DF</b></p>  <p>HEIGHT 27 1/8 IN      53.7 CM WIDTH 7 5/8 IN      19.4 CM THICK 3/4 IN      1.9 CM WEIGHT 3.1 LBS      1.4 KGS</p>	<p><b>824</b>      <b>SF</b></p>  <p>HEIGHT 21 3/8 IN      54.3 CM WIDTH 10 IN      25.4 CM THICK 3/8 IN      1.0 CM WEIGHT 2.1 LBS      1.0 KGS</p>	<p><b>933</b>      <b>DF</b> NEW</p>  <p>HEIGHT 26 7/8 IN      71.1 CM WIDTH 14 3/4 IN      37.5 CM THICK 7/8 IN      2.2 CM WEIGHT 7.5 LBS      3.4 KGS</p>	<p><b>1070</b>      <b>DF</b></p>  <p>HEIGHT 24 IN      61.0 CM WIDTH 11 3/4 IN      29.8 CM THICK 1 IN      2.5 CM WEIGHT 5.1 LBS      2.3 KGS</p>
<p><b>775</b>      <b>SBO</b> OLD 775F</p>  <p>HEIGHT 5 IN      12.7 CM WIDTH 21 3/4 IN      55.2 CM THICK 7/8 IN      2.2 CM WEIGHT 2.2 LBS      1.0 KGS</p>		<p><b>790</b>      <b>DF</b> OLD 790F</p>  <p>HEIGHT 3 1/2 IN      8.9 CM WIDTH 27 IN      68.6 CM THICK 1/2 IN      1.3 CM WEIGHT 2.0 LBS      0.9 KGS</p>	

REVISION DATE: 01/19/95

SCALE: 1 INCH = 1 FOOT UNLESS NOTED



Section:

Toll Free (800) 527-1318

(972) 286-2368

Fax: (972) 557-4727

Pontalba  
Castings



**527**      **DF**

NOTE: NOT TO SCALE

HEIGHT	29 3/4 IN	75.6 CM
WIDTH	7 3/4 IN	19.7 CM
THICK	7/8 IN	2.2 CM
WEIGHT	3.5 LBS	1.6 KGS

**526**      **DF**  
OLD 526B

HEIGHT	14 3/4 IN	37.5 CM
WIDTH	15 1/2 IN	39.4 CM
THICK	3/4 IN	1.9 CM
WEIGHT	2.2 LBS	1.0 KGS

**555**      **DF**  
NEW

HEIGHT	15 IN	38.1 CM
WIDTH	15 IN	38.1 CM
THICK	5/8 IN	1.6 CM
WEIGHT	1.8 LBS	0.8 KGS

**864**      **DF**  
OLD 864B

HEIGHT	15 3/8 IN	39.1 CM
WIDTH	15 3/8 IN	39.1 CM
THICK	7/8 IN	2.2 CM
WEIGHT	2.2 LBS	1.0 KGS

**860**      **SBO**

HEIGHT	20 1/2 IN	52.1 CM
WIDTH	7 1/2 IN	19.0 CM
THICK	1/2 IN	1.3 CM
WEIGHT	1.5 LBS	0.7 KGS

**861**      **DF**

HEAVY WEIGHT

HEIGHT	20 IN	50.8 CM
WIDTH	7 1/4 IN	18.4 CM
THICK	3/4 IN	1.9 CM
WEIGHT	2.8 LBS	0.9 KGS

**863**      **DF**

TEXTURED SURFACE

LIGHT WEIGHT

HEIGHT	19 IN	48.3 CM
WIDTH	7 5/8 IN	19.4 CM
THICK	3/4 IN	1.9 CM
WEIGHT	2.0 LBS	0.9 KGS

**22**      **DF**  
] 1/2" [

HEIGHT	15 IN	38.1 CM
WIDTH	7 3/4 IN	19.7 CM
THICK	3/4 IN	1.9 CM
WEIGHT	2.1 LBS	1.0 KGS

**868**      **DF**  
NEW

HEIGHT	15 3/4 IN	40.0 CM
WIDTH	15 3/4 IN	40.0 CM
THICK	7/8 IN	2.2 CM
WEIGHT	2.4 LBS	1.1 KGS

**865**      **DF**

NOT TO SCALE

HEIGHT	33 IN	37.5 CM
WIDTH	7 3/8 IN	41.9 CM
THICK	5/8 IN	1.6 CM
WEIGHT	3.9 LBS	1.5 KGS

**825**      **DF**  
OLD 825B

HEIGHT	15 1/2 IN	39.4 CM
WIDTH	15 1/2 IN	39.4 CM
THICK	3/4 IN	1.9 CM
WEIGHT	2.4 LBS	1.1 KGS

**1852**      **DF**  
NEW

HEIGHT	14 5/8 IN	38.1 CM
WIDTH	14 5/8 IN	38.7 CM
THICK	3/4 IN	1.9 CM
WEIGHT	2.2 LBS	1.0 KGS

REVISION DATE: 12/21/94

SCALE: 1 INCH = 1 FOOT UNLESS NOTED

**862** **SBO**  
 NEW



HEIGHT	18 1/2 IN	47.0 CM
WIDTH	19 1/4 IN	48.9 CM
THICK	7/8 IN	2.2 CM
WEIGHT	2.6 LBS	1.2 KGS

Section:

Toll Free (800) 527-1318

(972) 286-2368

Fax: (972) 557-4727



ALUMINUM CASTINGS

Circles  
And Ovals

**1720** **DF**  
NEW

NOMINAL PICKET

5 3/4 IN.

CIRCLES ARE 5 1/8 IN. OUTSIDE DIAMETER.

LUGS BETWEEN CIRCLES HAVE 1/2" TAPERED DOWN TO 1/8" DIAMETER HOLE FOR SCREW ON APPLICATIONS.

HEIGHT 28 1/4 IN	71.8 CM
WIDTH 5 IN	12.7 CM
THICK 1/2 IN	1.3 CM
WEIGHT 2.1 LBS	1.0 KGS

**833 SBO**  
NEW

HEIGHT 29 1/2 IN	76.2 CM
WIDTH 4 3/8 IN	11.4 CM
THICK 1 IN	2.5 CM
WEIGHT 3.9 LBS	1.7 KGS

**534** **FB**  
NEW

HEIGHT 30 3/4 IN	78.1 CM
WIDTH 5 1/8 IN	13.0 CM
THICK 3/4 IN	1.9 CM
WEIGHT 3.8 LBS	1.7 KGS

**535** **FB**  
NEW

HEIGHT 34 1/8 IN	86.7 CM
WIDTH 8 IN	20.3 CM
THICK 3/4 IN	1.9 CM
WEIGHT 4.4 LBS	2.0 KGS

**836** **FB**  
NEW

HEIGHT 27 IN	68.6 CM
WIDTH 13 5/8 IN	34.6 CM
THICK 1/2 IN	1.3 CM
WEIGHT 2.4 LBS	1.1 KGS

**CIRCLES / RINGS** **FB**  
NO SCALE

NEW SIZES

**7134** 3 1/2"  
**7137** 3 7/8"  
**7150** 5"

STANDARD PLACEMENT OF CLIPS IS 2 AT 180 DEGREES APART.

TYPICAL CROSS SECTION

CATALOG NUMBER	OLD NUMBER	DIAMETER		WEIGHT	
		INCHES	CENTIMETERS	POUNDS	KILOGRAMS
<b>7110</b>	710X100	10	25.4	0.74	0.34
<b>7111</b>	710X110	11	27.9	0.88	0.40
<b>7130</b>	710X300	3	7.6	0.20	0.09
<b>7140</b>	710X400	4	10.2	0.25	0.11
<b>7144</b>	710X450	4 1/2	11.4	0.31	0.14
<b>7152</b>	710X514	5 1/4	13.3	0.43	0.20
<b>7157</b>	710X578	5 7/8	14.9	0.45	0.20
<b>7180</b>	710X800	8	20.3	0.63	0.29

**9272** **DF**  
NEW

HEIGHT 35 1/8 IN	89.2 CM
WIDTH 8 1/8 IN	20.6 CM
THICK 5/8 IN	1.6 CM
WEIGHT 6.5 LBS	3.0 KGS

REVISION DATE: 12/21/94

NOTE: MORE CIRCLES WITH STARS ARE ON PAGE 70.

SCALE: 1 INCH = 1 FOOT UNLESS NOTED



**536** **FB**  
NEW



HEIGHT 12 7/8 IN 32.7 CM  
WIDTH 5 1/8 IN 13.0 CM  
THICK 3/4 IN 1.9 CM  
WEIGHT 1.6 LBS 0.8 KGS

**537** **FB**  
NEW



HEIGHT 16 1/4 IN 41.3 CM  
WIDTH 8 IN 20.3 CM  
THICK 3/4 IN 1.9 CM  
WEIGHT 2.0 LBS 0.9 KGS

**808** **SF**



HEIGHT 15 1/2 IN 39.4 CM  
WIDTH 6 7/8 IN 17.5 CM  
THICK 1/2 IN 1.3 CM  
WEIGHT 1.6 LBS 0.7 KGS

**855** **SF**



HEIGHT 19 5/8 IN 49.8 CM  
WIDTH 9 7/8 IN 25.1 CM  
THICK 3/8 IN 0.9 CM  
WEIGHT 2.2 LBS 1.0 KGS

**707** **DF**  
NEW



HEIGHT 8 1/2 IN 21.6 CM  
WIDTH 8 1/2 IN 21.6 CM  
THICK 7/8 IN 2.2 CM  
WEIGHT 1.2 LBS 0.6 KGS

**881** **DF**



HEIGHT 7 IN 17.8 CM  
WIDTH 7 IN 17.8 CM  
THICK 3/4 IN 1.9 CM  
WEIGHT 1.3 LBS 0.6 KGS

**1624** **DF**  
OLD 624M



HEIGHT 7 3/4 IN 19.7 CM  
WIDTH 7 3/4 IN 19.7 CM  
THICK 3/4 IN 1.9 CM  
WEIGHT 1.2 LBS 0.6 KGS

**2300** **DF**  
OLD 300M



SCALE: 1/2 INCH = 1 FOOT

HEIGHT 7 1/2 IN 19.0 CM  
WIDTH 7 1/2 IN 19.0 CM  
THICK 5/8 IN 1.6 CM  
WEIGHT 1.1 LBS 0.5 KGS

**858** **SF**



HEIGHT 15 IN 38.1 CM  
WIDTH 15 IN 38.1 CM  
THICK 1/2 IN 1.3 CM  
WEIGHT 2.6 LBS 1.2 KGS

**811** **SF**

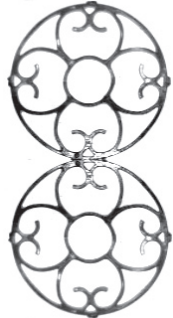

HEIGHT 20 1/4 IN 51.4 CM  
WIDTH 10 1/2 IN 26.7 CM  
THICK 3/8 IN 0.9 CM  
WEIGHT 2.6 LBS 1.2 KGS

**1811** **SF**  
NEW



HEIGHT 15 1/4 IN 38.7 CM  
WIDTH 15 1/4 IN 38.7 CM  
THICK 3/8 IN 0.9 CM  
WEIGHT 1.3 LBS 0.6 KGS

**2811** **SF**  
NEW



HEIGHT 4 IN 10.2 CM  
WIDTH 19 1/8 IN 48.6 CM  
THICK 1/2 IN 1.3 CM  
WEIGHT 1.3 LBS 0.8 KGS

REVISION DATE: 01/30/95

NOTE: MORE CIRCLES WITH STARS ARE SHOWN ON PAGE 70.

SCALE: 1 INCH = 1 FOOT UNLESS NOTED

Section:

Toll Free (800) 527-1318

(972) 286-2368

Fax: (972) 557-4727



ALUMINUM CASTINGS

Circles  
And Ovals

839

DF



HEIGHT	18 3/8 IN	46.7 CM
WIDTH	9 1/8 IN	23.2 CM
THICK	1/2 IN	1.3 CM
WEIGHT	1.8 LBS	0.8 KGS

840

DF



HEIGHT	20 3/8 IN	51.8 CM
WIDTH	9 1/4 IN	23.5 CM
THICK	1/2 IN	1.3 CM
WEIGHT	2.9 LBS	1.3 KGS

841

DF

OLD 841F



HEIGHT	4 1/2 IN	11.4CM
WIDTH	19 3/4 IN	50.2CM
THICK	7/8 IN	2.2CM
WEIGHT	1.6 LBS	0.8 KGS

9263

SF

NEW



HEIGHT	14 IN	35.6 CM
WIDTH	14 IN	35.6 CM
THICK	1 3/8 IN	3.5 CM
WEIGHT	3.0 LBS	1.4 KGS

9331

DF

NEW



HEIGHT	31 7/8 IN	81.0 CM
WIDTH	9 IN	22.9 CM
THICK	1 5/8 IN	4.1 CM
WEIGHT	8.8 LBS	4.0 KGS

9237

DF

NEW

SCALE: 2 INCHES = 1 FOOT



THIS PIECE WAS USED WITH CATALOG  
NUMBER 8211 AT THE VISITORS CENTER,  
THE WHITE HOUSE, WASHINGTON, D.C.

HEIGHT	6 7/8 IN	17.5 CM
WIDTH	6 7/8 IN	17.5 CM
THICK	1 1/4 IN	3.2 CM
WEIGHT	2.2 LBS	1.0 KGS

7121

DF

NEW

21 INCHES DIAMETER



CIRCLE HAS A NOMINAL CROSS  
SECTION OF 3/4 INCH BY 3/4 INCH

HEIGHT	21 IN	53.3	CM
WIDTH	21 IN	53.3	CM
THICK	3/4 IN	1.9CM	
WEIGHT	2.1 LBS	1.0KGS	

REVISION DATE: 01/30/95

NOTE: MORE CIRCLES WITH STARS ARE SHOWN ON PAGE 70.

SCALE:1 INCH = 1 FOOT UNLESS NOTED



# Alloy Casting

## ALUMINUM CASTINGS

Toll Free (800) 527-1318

(972) 286-2368

Fax: (972) 557-4727

Section:

Circle Castings

**8405**      **FB**  
NEW



HEIGHT 5 5/8 IN      14.3 CM  
WIDTH 5 5/8 IN      14.3 CM  
THICK 1/2 IN      1.3 CM  
WEIGHT 0.8 LBS      0.4 KGS

**8406**      **DF**  
NEW



HEIGHT 5 5/8 IN      14.3 CM  
WIDTH 5 5/8 IN      14.3 CM  
THICK 1/2 IN      1.3 CM  
WEIGHT 0.8 LBS      0.5 KGS

**8407**      **DF**  
NEW



HEIGHT 5 5/8 IN      14.3 CM  
WIDTH 5 5/8 IN      14.3 CM  
THICK 1/2 IN      1.3 CM  
WEIGHT 0.7 LBS      0.3 KGS

**8408**      **DF**  
NEW



HEIGHT 5 5/8 IN      14.3 CM  
WIDTH 5 5/8 IN      14.3 CM  
THICK 1/2 IN      1.3 CM  
WEIGHT 0.7 LBS      0.3 KGS

**8409**      **DF**  
NEW



HEIGHT 5 5/8 IN      14.3 CM  
WIDTH 5 5/8 IN      14.3 CM  
THICK 1/2 IN      1.3 CM  
WEIGHT 0.7 LBS      0.3 KGS

**8411**      **DF**  
NEW



HEIGHT 5 5/8 IN      14.3 CM  
WIDTH 5 5/8 IN      14.3 CM  
THICK 1/2 IN      1.3 CM  
WEIGHT 0.7 LBS      0.3 KGS

**8412**      **DF**  
NEW



HEIGHT 5 5/8 IN      14.3 CM  
WIDTH 5 5/8 IN      14.3 CM  
THICK 1/2 IN      1.3 CM  
WEIGHT 0.7 LBS      0.3 KGS

**8413**      **DF**  
NEW



HEIGHT 5 5/8 IN      14.3 CM  
WIDTH 5 5/8 IN      14.3 CM  
THICK 1/2 IN      1.3 CM  
WEIGHT 0.7 LBS      0.3 KGS

**8402**      **FB**  
NEW



SCALE: 2 INCHES = 1 FOOT

HEIGHT 5 5/8 IN      14.3 CM  
WIDTH 5 5/8 IN      14.3 CM  
THICK 1/2 IN      1.3 CM  
WEIGHT 0.6 LBS      0.2 KGS

NOTE: THE CIRCLES ON THIS PAGE FIT INTO THE BENCH END ARM RESTS, SEE PAGE 95.

REVISION DATE: 01/20/95

SCALE: 2 INCHES = 1 FOOT UNLESS NOTED

Section:  
**Modern Design  
 Castings**

Toll Free (800) 527-1318  
 (972) 286-2368  
 Fax: (972) 557-4727



**809**      **DF**



HEIGHT 21 3/4 IN      55.2 CM  
 WIDTH 11 IN      27.9 CM  
 THICK 1/2 IN      1.3 CM  
 WEIGHT 2.6 LBS      1.2 KGS

**843**      **SF**

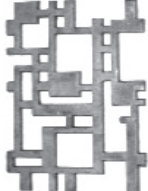

HEIGHT 12 1/4 IN      31.1 CM  
 WIDTH 9 1/4 IN      23.5 CM  
 THICK 1/2 IN      1.3 CM  
 WEIGHT 2.1 LBS      1.0 KGS

**838**      **DF**  
 NEW



HEIGHT 8 3/8 IN      21.3 CM  
 WIDTH 8 3/8 IN      21.3 CM  
 THICK 1/2 IN      1.3 CM  
 WEIGHT 1.1 LBS      0.5 KGS

**180**      **SF**  
 ] 1/2" [

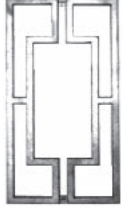

HEIGHT 13 1/4 IN      33.7 CM  
 WIDTH 7 3/8 IN      18.7 CM  
 THICK 3/4 IN      1.9 CM  
 WEIGHT 1.5 LBS      0.7 KGS

**28**      **SF**  
 ] 1/2" [



HEIGHT 6 3/4 IN      17.1 CM  
 WIDTH 6 3/4 IN      17.1 CM  
 THICK 3/4 IN      1.9 CM  
 WEIGHT 1.1 LBS      0.5 KGS

**821**      **SF**

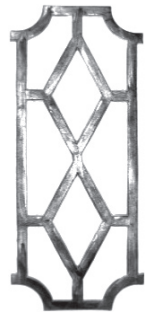

HEIGHT 19 1/2 IN      49.5 CM  
 WIDTH 8 5/8 IN      21.9 CM  
 THICK 1/4 IN      0.6 CM  
 WEIGHT 1.5 LBS      0.7 KGS

**810**      **FB**

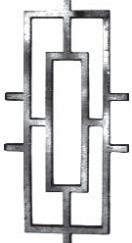

HEIGHT 15 3/4 IN      40.0 CM  
 WIDTH 7 7/8 IN      20.0 CM  
 THICK 1/2 IN      1.3 CM  
 WEIGHT 1.6 LBS      0.7 KGS

**530**      **DF**  
 NEW



1  
 2 1/2

ENDS APPROX. 5/8 SQ

HEIGHT 9 7/8 IN      25.1 CM  
 WIDTH 5 1/4 IN      13.3 CM  
 THICK 1 1/8 IN      2.9 CM  
 WEIGHT 0.6 LBS      0.3 KGS

REVISION DATE: 12/22/94

SCALE: 1 INCH = 1 FOOT UNLESS NOTED





# Alloy Casting

## ALUMINUM CASTINGS

Toll Free (800) 527-1318

(972) 286-2368

Fax: (972) 557-4727

Section:

**Modern Design  
Castings**

**834**      **SF**  
NEW

SIDE ARMS HAVE INDENTIONS FOR SCREW ON APPLICATIONS.

HEIGHT 21 7/8 IN	55.6 CM
WIDTH 9 IN	22.9 CM
THICK 1/2 IN	1.3 CM
WEIGHT 2.3 LBS	1.0 KGS

**806**      **FB**

HEIGHT 28 5/8 IN	71.8 CM
WIDTH 8 3/8 IN	21.0 CM
THICK 1/2 IN	1.3 CM
WEIGHT 4.2 LBS	1.9 KGS

**802**      **FB**

HEIGHT 24 5/8 IN	62.2 CM
WIDTH 9 3/4 IN	24.8 CM
THICK 1/2 IN	1.6 CM
WEIGHT 3.4 LBS	1.5 KGS

**803**      **FB**

HEIGHT 23 1/2 IN	59.1 CM
WIDTH 8 7/8 IN	22.5 CM
THICK 3/8 IN	1.6 CM
WEIGHT 2.4 LBS	1.1 KGS

**1802**      **FB**  
OLD 802B

HEIGHT 15 3/4 IN	40.0 CM
WIDTH 15 3/4 IN	40.0 CM
THICK 1 IN	2.5 CM
WEIGHT 2.6 LBS	1.2 KGS

**7781**      **DF**  
NEW      SAFE **4"** SAFE

HEIGHT 20 IN	50.8 CM
WIDTH 20 IN	50.8 CM
THICK 1 IN	2.5 CM
WEIGHT 12.5 LBS	5.7 KGS

REVISION DATE: 12/22/94

SCALE: 1 INCH = 1 FOOT UNLESS NOTED

Section:  
Mixed  
Castings

Toll Free (800) 527-1318

(972) 286-2368

Fax: (972) 557-4727



**856 DF**

HEIGHT 19 1/4 IN	48.9 CM
WIDTH 7 1/4 IN	18.4 CM
THICK 3/8 IN	1.0 CM
WEIGHT 1.9 LBS	0.8 KGS

**1858 DF**  
OLD 858F

NOT TO SCALE

HEIGHT 4 IN	10.5 CM
WIDTH 19 1/2 IN	49.5 CM
THICK 3/4 IN	1.9 CM
WEIGHT 1.1 LBS	0.5 KGS



Panel section #813 grouped as a window screen.

**813 FB**

HEIGHT 20 3/4 IN	52.7 CM
WIDTH 9 3/4 IN	24.8 CM
THICK 5/16 IN	0.8 CM
WEIGHT 1.8 LBS	0.8 KGS

**1814 FB**  
OLD 814B

HEIGHT 15 1/8 IN	38.4 CM
WIDTH 15 1/8 IN	38.4 CM
THICK 1/2 IN	1.3 CM
WEIGHT 2.5 LBS	1.1 KGS

**815 FB**  
OLD 815F

HEIGHT 5 IN	12.7 CM
WIDTH 15 3/4 IN	40.0 CM
THICK 1/2 IN	1.3 CM
WEIGHT 0.9 LBS	0.3 KGS

**850 SBO**

HEIGHT 23 IN	58.4 CM
WIDTH 6 IN	15.2 CM
THICK 5/8 IN	1.6 CM
WEIGHT 1.6 LBS	0.7 KGS

**807 SF**

HEIGHT 20 3/8 IN	54.3 CM
WIDTH 9 1/2 IN	24.1 CM
THICK 3/8 IN	1.0 CM
WEIGHT 1.4 LBS	0.6 KGS

**1807 SF**  
OLD 807B

HEIGHT 13 IN	33.0 CM
WIDTH 13 IN	33.0 CM
THICK 3/8 IN	0.9 CM
WEIGHT 0.9 LBS	0.4 KGS

**2807 SF**  
OLD 807F

HEIGHT 4 7/8 IN	12.4 CM
WIDTH 21 1/4 IN	54.0 CM
THICK 3/8 IN	1.0 CM
WEIGHT 0.8 LBS	0.4 KGS

**851 SBO**  
OLD 851F

NOT TO SCALE

HEIGHT 4 7/8 IN	12.4 CM
WIDTH 21 1/4 IN	54.0 CM
THICK 7/8 IN	2.2 CM
WEIGHT 2.2 LBS	1.0 KGS

REVISION DATE: 03/20/95

SCALE: 1 INCH = 1 FOOT UNLESS NOTED

**827** **FB**



HEIGHT 17 1/4 IN 43.8 CM  
 WIDTH 7 1/4 IN 18.4 CM  
 THICK 3/8 IN 1.0 CM  
 WEIGHT 1.3 LBS 0.6 KGS

**8559** **FB**  
NEW

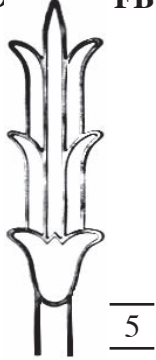

NOTE: NOT TO SCALE

HEIGHT 32 1/2 IN 82.6 CM  
 WIDTH 8 7/8 IN 22.5 CM  
 THICK 5/8 IN 1.6 CM  
 WEIGHT 3.2 LBS 1.5 KGS

**630** **DF**



HEIGHT 22 5/8 IN 57.5 CM  
 WIDTH 9 1/4 IN 23.5 CM  
 THICK 5/8 IN 1.6 CM  
 WEIGHT 3.0 LBS 1.4 KGS

**1630** **DF**  
OLD 630B

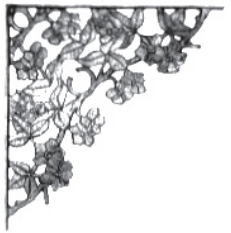

HEIGHT 14 1/4 IN 36.2 CM  
 WIDTH 14 3/4 IN 37.5 CM  
 THICK 7/8 IN 2.2 CM  
 WEIGHT 2.2 LBS 1.0 KGS

**24** **DF**  
] 1/2" [



HEIGHT 14 7/8 IN 37.8 CM  
 WIDTH 8 1/8 IN 20.6 CM  
 THICK 3/4 IN 1.9 CM  
 WEIGHT 1.2 LBS 0.6 KGS

**120** **DF**



HEIGHT 19 5/8 IN 49.9 CM  
 WIDTH 8 IN 20.3 CM  
 THICK 5/8 IN 1.6 CM  
 WEIGHT 1.8 LBS 0.8 KGS

**122** **DF**  
OLD 122F



HEIGHT 4 1/8 IN 47.0 CM  
 WIDTH 19 1/2 IN 32.1 CM  
 THICK 3/4 IN 1.9 CM  
 WEIGHT 1.0 LBS 0.5 KGS

**121** **DF**  
OLD 121B



HEIGHT 13 1/2 IN 34.3 CM  
 WIDTH 17 1/4 IN 43.8 CM  
 THICK 3/4 IN 1.9 CM  
 WEIGHT 1.7 LBS 0.8 KGS

**816** **FB**



HEIGHT 18 3/8 IN 46.7 CM  
 WIDTH 9 3/4 IN 24.5 CM  
 THICK 3/8 IN 1.0 CM  
 WEIGHT 2.4 LBS 1.1 KGS

**3818** **FB**  
OLD 818B



HEIGHT 15 IN 38.1 CM  
 WIDTH 15 IN 38.1 CM  
 THICK 1/2 IN 1.3 CM  
 WEIGHT 1.8 LBS 0.8 KGS

**817** **FB**  
OLD 817F



HEIGHT 5 IN 12.7 CM  
 WIDTH 19 1/2 IN 49.5 CM  
 THICK 1/2 IN 1.3 CM  
 WEIGHT 1.4 LBS 0.6 KGS

Section:

Toll Free (800) 527-1318

(972) 286-2368

Fax: (972) 557-4727



# Alloy Casting

## ALUMINUM CASTINGS

### Mixed Castings

**550 DF**



HEIGHT	28 5/8 IN	72.7 CM
WIDTH	10 IN	25.4 CM
THICK	3/4 IN	1.9 CM
WEIGHT	4.5 LBS	1.8 KGS

**2550 DF**  
NEW



HEIGHT	27 1/4 IN	69.2 CM
WIDTH	9 1/2 IN	24.1 CM
THICK	3/4 IN	1.9 CM
WEIGHT	4.8 LBS	2.2 KGS

**553 DF**  
NEW



HEIGHT	27 IN	68.6 CM
WIDTH	9 IN	22.8 CM
THICK	1 IN	2.5 CM
WEIGHT	4.4 LBS	1.8 KGS

**552 DF**



HEIGHT	19 5/8 IN	49.8 CM
WIDTH	5 5/8 IN	14.3 CM
THICK	7/8 IN	2.2 CM
WEIGHT	2.5 LBS	1.1 KGS

**801 DF**



HEIGHT	27 3/4 IN	70.5 CM
WIDTH	8 1/8 IN	20.6 CM
THICK	1/2 IN	1.3 CM
WEIGHT	2.2 LBS	1.0 KGS

**1803 DF**  
OLD 803BNB



HEIGHT	9 1/4 IN	75.6 CM
WIDTH	19 3/8 IN	17.8 CM
THICK	5/8 IN	1.3 CM
WEIGHT	2.2 LBS	0.8 KGS

**804 DF**



HEIGHT	29 3/4 IN	75.6 CM
WIDTH	7 IN	17.8 CM
THICK	1/2 IN	1.3 CM
WEIGHT	2.1 LBS	1.0 KGS

**800 DF**



HEIGHT	28 5/8 IN	72.7 CM
WIDTH	8 3/8 IN	21.3 CM
THICK	1/2 IN	1.3 CM
WEIGHT	2.5 LBS	1.1 KGS

REVISION DATE: 12/22/94

SCALE: 1 INCH = 1 FOOT UNLESS NOTED





# Alloy Casting

## ALUMINUM CASTINGS

Toll Free (800) 527-1318

(972) 286-2368

Fax: (972) 557-4727

Section:

**Mixed  
Castings**

**701**      **SBO**  
NEW

HEIGHT 28 1/2 IN	72.4 CM
WIDTH 9 IN	22.9 CM
THICK 7/8 IN	2.2 CM
WEIGHT 4.1 LBS	1.9 KGS

**705**      **DF**  
NEW

HEIGHT 26 1/8 IN	66.4 CM
WIDTH 8 1/2 IN	21.6 CM
THICK 1/2 IN	1.3 CM
WEIGHT 3.1 LBS	1.4 KGS

**706**      **DF**  
OLD 706B

HEIGHT 12 3/4 IN	32.4 CM
WIDTH 24 1/4 IN	59.1 CM
THICK 3/4 IN	1.9 CM
WEIGHT 3.1 LBS	1.4 KGS

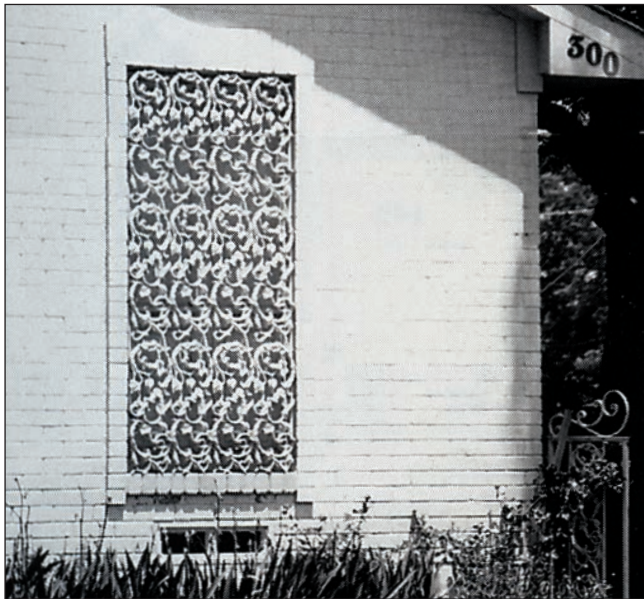

Panel casting #705 group as a window screen/window guard.

REVISION DATE: 12/23/94

SCALE: 1 INCH = 1 FOOT UNLESS NOTED

Section:

Toll Free (800) 527-1318

(972) 286-2368

Fax: (972) 557-4727

Mixed Castings



500 DF



HEIGHT	25 1/2 IN	64.8 CM
WIDTH	11 IN	16.5 CM
THICK	1 1/4 IN	3.2 CM
WEIGHT	5.9 LBS	2.7 KGS

981 DF



HEIGHT	27 1/4 IN	69.2 CM
WIDTH	13 IN	33.0 CM
THICK	3/4 IN	1.9 CM
WEIGHT	7.5 LBS	4.0 KGS

501

OLD 501B



DF

HEIGHT	14 3/4 IN
WIDTH	16 1/2 IN
THICK	1 IN
WEIGHT	3.2 LBS

37.5 CM
41.9 CM
2.5 CM
1.5 KGS

502

OLD 502F



DF

HEIGHT	6 IN
WIDTH	21 IN
THICK	1 IN
WEIGHT	3.4 LBS

15.2 CM
53.3 CM
2.5 CM
1.5 KGS

503

OLD 503F



DF

HEIGHT	9 7/8 IN
WIDTH	20 3/4 IN
THICK	1 1/8 IN
WEIGHT	4.1 LBS

15.2 CM
53.3 CM
2.5 CM
1.5 KGS

640

NEW

DF



MAGNOLIA

HEIGHT	27 3/4 IN	70.5 CM
WIDTH	9 1/2 IN	24.1 CM
THICK	7/8 IN	2.2 CM
WEIGHT	4.2 LBS	1.9 KGS

641

NEW

DF



MAGNOLIA

HEIGHT	16 IN	40.6 CM
WIDTH	16 IN	40.6 CM
THICK	7/8 IN	2.2 CM
WEIGHT	3.8 LBS	1.7 KGS

REVISION DATE: 01/30/95

SCALE: 1 INCH = 1 FOOT UNLESS NOTED

**650 DF**



HEIGHT 21 IN	53.3 CM
WIDTH 6 1/8 IN	15.6 CM
THICK 7/8 IN	2.2 CM
WEIGHT 2.6 LBS	1.2 KGS

**651 DF**  
OLD 651BNB



HEIGHT 15 1/2 IN	39.4 CM
WIDTH 19 1/4 IN	48.9 CM
THICK 3/4 IN	1.9 CM
WEIGHT 3.3 LBS	1.5 KGS

**510 DF**



NOT TO SCALE

HEIGHT 31 3/4 IN	80.6 CM
WIDTH 9 1/4 IN	23.5 CM
THICK 3/4 IN	1.9 CM
WEIGHT 4.2 LBS	2.0 KGS

**520 DF**  
OLD 520F



HEIGHT 6 IN	15.2 CM
WIDTH 18 1/4 IN	46.4 CM
THICK 3/4 IN	1.9 CM
WEIGHT 1.7 LBS	0.8 KGS

**875 DF**  
NEW



HEIGHT 23 IN	58.4 CM
WIDTH 6 IN	15.2 CM
THICK 5/8 IN	1.6 CM
WEIGHT 1.6 LBS	0.7 KGS

**876 DF**  
NEW



HEIGHT 8 1/4 IN	21.0 CM
WIDTH 23 1/2 IN	59.7 CM
THICK 3/4 IN	1.9 CM
WEIGHT 1.1 LBS	0.5 KGS

**956 DF**  
NEW



HEIGHT 26 IN	66.0 CM
WIDTH 8 3/4 IN	22.2 CM
THICK 7/8 IN	2.2 CM
WEIGHT 3.8 LBS	1.7 KGS

**894 DF**  
OLD 894BNB



HEIGHT 10 1/2 IN	26.7 CM
WIDTH 19 3/4 IN	50.2 CM
THICK 3/4 IN	1.9 CM
WEIGHT 1.8 LBS	0.8 KGS

**9219 DF**  
NEW



HEIGHT 7 IN	17.7 CM
WIDTH 6 1/4 IN	15.9 CM
THICK 1 IN	2.5 CM
WEIGHT 1.0 LBS	0.4 KGS

**9222 DF**  
NEW



HEIGHT 22 IN	55.9 CM
WIDTH 22 IN	55.9 CM
THICK 1 IN	2.5 CM
WEIGHT 5.7 LBS	2.6 KGS

**9254 DF**  
NEW



NOT TO SCALE

HEIGHT 27 3/4 IN	70.5 CM
WIDTH 10 5/8 IN	27.1 CM
THICK 1 IN	2.5 CM
WEIGHT 6.0 LBS	2.7 KGS

**9283 DF**  
NEW



"HANGING SWING" ARM

HEIGHT 12 1/4 IN	31.8 CM
WIDTH 17 1/2 IN	44.4 CM
THICK 1 3/4 IN	4.4 CM
WEIGHT 3.6 LBS	1.6 KGS

Section:

Toll Free (800) 527-1318

(972) 286-2368

Fax: (972) 557-4727

Mixed Castings



**812** **DF**

HEIGHT 28 IN 71.1 CM  
 WIDTH 9 1/2 IN 24.1 CM  
 THICK 1 1/8 IN 2.9 CM  
 WEIGHT 1.7 LBS 0.8 KGS

**1812** **DF**  
 OLD 812B

HEIGHT 13 3/8 IN 34.0 CM  
 WIDTH 22 1/4 IN 56.5 CM  
 THICK 3/4 IN 1.9 CM  
 WEIGHT 3.1 LBS 1.4 KGS

**940** **DF**

HEIGHT 24 1/4 IN 61.6 CM  
 WIDTH 9 IN 22.9 CM  
 THICK 1 IN 2.5 CM  
 WEIGHT 4.2 LBS 1.9 KGS

**852** **DF**

HEIGHT 18 IN 45.7 CM  
 WIDTH 7 IN 17.8 CM  
 THICK 5/8 IN 1.6 CM  
 WEIGHT 2.7 LBS 1.2 KGS

**805** **DF**

HEIGHT 18 3/8 IN 38.1 CM  
 WIDTH 9 3/4 IN 12.7 CM  
 THICK 5/8 IN 1.6 CM  
 WEIGHT 2.1 LBS 1.0 KGS

**823** **FB**

HEIGHT 14 1/4 IN 36.2 CM  
 WIDTH 8 1/2 IN 21.6 CM  
 THICK 3/8 IN 1.0 CM  
 WEIGHT 1.2 LBS 0.6 KGS

**125** **SF**

HEIGHT 14 1/8 IN 35.9 CM  
 WIDTH 8 1/8 IN 20.6 CM  
 THICK 3/8 IN 0.9 CM  
 WEIGHT 1.0 LBS 0.4 KGS

REVISION DATE: 12/23/94

SCALE: 1 INCH = 1 FOOT UNLESS NOTED





# Alloy Casting

## ALUMINUM CASTINGS

Toll Free (800) 527-1318

(972) 286-2368

Fax: (972) 557-4727

Section:

Miscellaneous  
Castings

**768**      **SF**  
OLD 768SF

SINGLE FACE

HEIGHT 22 1/8 IN	56.2 CM
WIDTH 7 3/4 IN	19.7 CM
THICK 1/2 IN	1.3 CM
WEIGHT 2.2 LBS	1.0 KGS

**769**      **DF**  
OLD 768DF

DOUBLE FACE

HEIGHT 22 1/8 IN	56.2 CM
WIDTH 7 3/4 IN	19.7 CM
THICK 3/4 IN	1.9 CM
WEIGHT 4.0 LBS	1.8 KGS

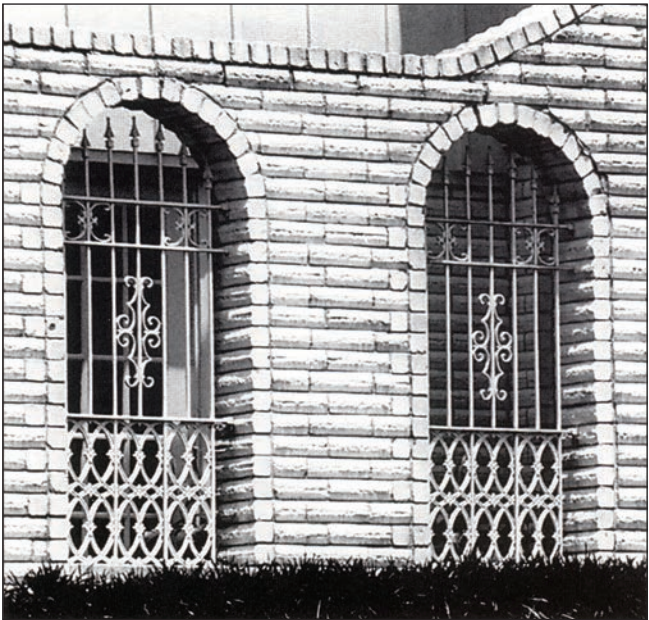

Picket castings #2 and #9 combined with spear point #8206 and panel #769 as a security divider.

**908**      **SF**  
OLD 908SF

SINGLE FACE

HEIGHT 30 IN	76.2 CM
WIDTH 8 IN	20.3 CM
THICK 1/2 IN	1.3 CM
WEIGHT 3.3 LBS	1.5 KGS

**909**      **DF**  
OLD 908DF

DOUBLE FACE

HEIGHT 30 IN	76.2 CM
WIDTH 8 IN	20.3 CM
THICK 7/8 IN	2.2 CM
WEIGHT 6.5 LBS	3.3 KGS

**818**      **SF**  
OLD 818SF

SINGLE FACE

HEIGHT 24 IN	61.0 CM
WIDTH 9 IN	22.9 CM
THICK 1/2 IN	1.3 CM
WEIGHT 3.1 LBS	1.1 KGS

**1818**      **DF**  
NEW

DOUBLE FACE

HEIGHT 24 IN	61.0 CM
WIDTH 9 IN	22.9 CM
THICK 1/2 IN	2.2 CM
WEIGHT 5.0 LBS	2.3 KGS

REVISION DATE: 12/23/94

SCALE: 1 INCH = 1 FOOT UNLESS NOTED

Section:

Toll Free (800) 527-1318

(972) 286-2368

Fax: (972) 557-4727



**Alloy Casting**

ALUMINUM CASTINGS

**Miscellaneous Castings**

**900 SBO**

HEIGHT 28 1/8 IN	71.4 CM
WIDTH 11 1/8 IN	28.2 CM
THICK 7/8 IN	2.2 CM
WEIGHT 5.1 LBS	2.3 KGS

**9294 DF**  
NEW

ENDS ARE 3/4 INCHES IN DIAMETER.

8 1/4 INCHES

22 1/2 INCHES

8 1/4 INCHES

ENDS ARE 3/4 INCHES IN DIAMETER.

HEIGHT 39 IN	99.1 CM
WIDTH 5 IN	12.7 CM
THICK 3/4 IN	1.9 CM
WEIGHT 3.6 LBS	1.6 KGS

**887 DF**  
NEW

HEIGHT 28 1/2 IN	72.4 CM
WIDTH 6 5/8 IN	16.8 CM
THICK 7/8 IN	2.2 CM
WEIGHT 3.4 LBS	1.6 KGS

**901 DF**

HEIGHT 24 1/4 IN	61.6 CM
WIDTH 7 3/4 IN	19.7 CM
THICK 3/4 IN	1.9 CM
WEIGHT 2.9 LBS	1.3 KGS

**950 DF**

HEIGHT 25 1/4 IN	64.2 CM
WIDTH 12 5/8 IN	32.1 CM
THICK 5/8 IN	1.6 CM
WEIGHT 4.6 LBS	2.1 KGS

**951 DF**

HEIGHT 13 3/4 IN	34.9 CM
WIDTH 12 3/8 IN	32.1 CM
THICK 7/8 IN	2.2 CM
WEIGHT 1.0 LBS	0.4 KGS

**955 SF**

HEIGHT 26 1/2 IN	67.3 CM
WIDTH 7 5/8 IN	19.4 CM
THICK 3/4 IN	1.9 CM
WEIGHT 3.8 LBS	1.7 KGS

**820 DF**

HEIGHT 28 IN	71.1 CM
WIDTH 10 IN	25.4 CM
THICK 1 IN	2.5 CM
WEIGHT 4.4 LBS	2.0 KGS

REVISION DATE: 01/30/95

SCALE: 1 INCH = 1 FOOT UNLESS NOTED

**930**      **DF**  
NEW

SAFE **4"** SAFE



HEIGHT 29	IN	72.7	CM
WIDTH 14	IN	35.6	CM
THICK 3/4	IN	1.9	CM
WEIGHT 4.5	LBS	12.0	KGS

**932**      **DF**  
NEW

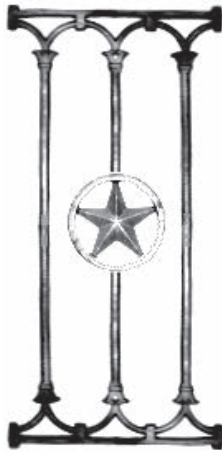

INQUIRY

HEIGHT 28 5/8	IN	72.7	CM
WIDTH 14	IN	35.6	CM
THICK 5/8	IN	1.6	CM
WEIGHT 5.2	LBS	2.4	KGS

**931**      **DF**  
NEW

SAFE **4"** SAFE



HEIGHT 29 1/2	IN	72.7	CM
WIDTH 14	IN	35.6	CM
THICK 5/8	IN	1.6	CM
WEIGHT 4.9	LBS	2.2	KGS

**934**      **DF**  
NEW

SAFE **4"** SAFE



HEIGHT 29 1/2	IN	72.7	CM
WIDTH 14 1/4	IN	35.6	CM
THICK 5/8	IN	1.6	CM
WEIGHT 4.6	LBS	1.6	KGS

**970**      **SBO**



HEIGHT 27 1/2	IN	69.8	CM
WIDTH 12 3/8	IN	31.4	CM
THICK 1	IN	2.5	CM
WEIGHT 5.5	LBS	2.5	KGS

**985**      **SBO**



HEIGHT 28 1/2	IN	72.4	CM
WIDTH 11 1/4	IN	28.6	CM
THICK 7/8	IN	2.2	CM
WEIGHT 8.3	LBS	2.3	KGS

**9232**      **DF**  
NEW



HEIGHT 34	IN	86.3	CM
WIDTH 7 1/4	IN	18.4	CM
THICK 5/8	IN	1.6	CM
WEIGHT 4.4	LBS	2.0	KGS

**957**      **DF**  
NEW



HEIGHT 25 1/4	IN	64.1	CM
WIDTH 9	IN	22.9	CM
THICK 1	IN	2.5	CM
WEIGHT 3.6	LBS	1.6	KGS

Section:

Toll Free (800) 527-1318

(972) 286-2368

Fax: (972) 557-4727

Mixed Castings



814 SF



HEIGHT	20 3/4 IN	52.7 CM
WIDTH	6 IN	15.2 CM
THICK	1/2 IN	1.3 CM
WEIGHT	2.5 LBS	1.1 KGS

828 DF



HEIGHT	15 3/8 IN	39.1 CM
WIDTH	4 3/8 IN	11.1 CM
THICK	1/2 IN	1.3 CM
WEIGHT	1.6 LBS	0.7 KGS

819 SF



HEIGHT	15 1/4 IN	38.7 CM
WIDTH	7 5/8 IN	19.4 CM
THICK	7/8 IN	2.2 CM
WEIGHT	1.0 LBS	0.4 KGS

591 DF

OLD 591B



HEIGHT	13 IN	38.1 CM
WIDTH	8/14 IN	12.7 CM
THICK	1 IN	7.3 CM
WEIGHT	1.2 LBS	0.6 KGS

562 DF

OLD 562BNB



HEIGHT	6 1/2 IN	16.5 CM
WIDTH	12 3/4 IN	32.4 CM
THICK	5/8 IN	1.6 CM
WEIGHT	2.4 LBS	1.1 KGS

563 DF



HEIGHT	11 3/8 IN	28.9 CM
WIDTH	9 5/8 IN	24.4 CM
THICK	3/4 IN	1.9 CM
WEIGHT	1.2 LBS	0.6 KGS

592 DF

NEW



HEIGHT	11 3/8 IN	28.9 CM
WIDTH	12 IN	30.5 CM
THICK	5/8 IN	1.6 CM
WEIGHT	2.0 LBS	0.9 KGS



Panel #1070 and corners #591 combined as a designed fence section.

REVISION DATE: 12/23/94

SCALE: 1 INCH = 1 FOOT UNLESS NOTED





**ALUMINUM CASTINGS**

Toll Free (800) 527-1318

(972) 286-2368

Fax: (972) 557-4727

Section:

**Mixed Castings**

**878** **DF**  
NEW

HEIGHT 25 IN	63.5 CM
WIDTH 11 1/4 IN	28.6 CM
THICK 1/2 IN	1.3 CM
WEIGHT 2.6 LBS	1.2 KGS

**879** **DF**  
NEW

HEIGHT 23 1/4 IN	60.0 CM
WIDTH 10 1/4 IN	26.0 CM
THICK 1/2 IN	1.3 CM
WEIGHT 2.6 LBS	1.2 KGS

**880** **DF**

HEIGHT 26 IN	66.0 CM
WIDTH 10 7/8 IN	27.6 CM
THICK 1/2 IN	1.3 CM
WEIGHT 1.6 LBS	0.7 KGS

**874** **DF**  
NEW

HEIGHT 23 5/8 IN	60.0 CM
WIDTH 10 1/4 IN	26.0 CM
THICK 3/4 IN	1.9 CM
WEIGHT 2.5 LBS	1.1 KGS

**877** **DF**  
NEW

HEIGHT 16 7/8 IN	42.9 CM
WIDTH 23 IN	58.4 CM
THICK 1 IN	1.9 CM
WEIGHT 4.1 LBS	1.9 KGS

**9284** **DF**  
NEW

TOP DESIGN SECTION

HEIGHT 32 1/8 IN	81.6 CM
WIDTH 12 1/2 IN	31.8 CM
THICK 7/8 IN	2.2 CM
WEIGHT 8.1 LBS	3.7 KGS

**9285** **DF**  
NEW

BOTTOM DESIGN SECTION

HEIGHT 29 IN	73.7 CM
WIDTH 13 1/4 IN	33.7 CM
THICK 7/8 IN	2.2 CM
WEIGHT 8.0 LBS	3.6 KGS

MATCHING PIECES. THESE CAN BE PUT END TO END FOR EXTRA LENGTH, OR BE USED AS INDIVIDUAL PIECES.

MID POINT

REVISION DATE: 01/30/95

SCALE: 1 INCH = 1 FOOT UNLESS NOTED

Section:

Heavy Duty Castings

Toll Free (800) 527-1318

(972) 286-2368

Fax: (972) 557-4727



**7781**      **DF**  
NEW

**SAFE 4" SAFE**

HEIGHT	20	IN	50.8	CM
WIDTH	20	IN	50.8	CM
THICK	1	IN	2.5	CM
WEIGHT	12.5	LBS	5.7	KGS

**1070**      **DF**

HEIGHT	24	IN	61.0	CM
WIDTH	11 3/4	IN	29.8	CM
THICK	1	IN	2.5	CM
WEIGHT	5.1	LBS	2.3	KGS

**769**      **DF**

HEIGHT	22 1/8	IN	56.2	CM
WIDTH	7 3/4	IN	19.7	CM
THICK	3/4	IN	1.9	CM
WEIGHT	4.0	LBS	1.8	KGS

**886**      **DF**  
OLD 886DF

HEIGHT	27 3/8	IN	69.5	CM
WIDTH	9 5/8	IN	24.4	CM
THICK	3/4	IN	1.9	CM
WEIGHT	4.8	LBS	2.2	KGS

**909**      **DF**

HEIGHT	30	IN	76.2	CM
WIDTH	8	IN	20.3	CM
THICK	7/8	IN	2.2	CM
WEIGHT	3.2	LBS	1.5	KGS

**814**      **FB**

HEIGHT	20 3/4	IN	52.7	CM
WIDTH	6	IN	15.2	CM
THICK	1/2	IN	1.3	CM
WEIGHT	2.5	LBS	1.1	KGS

**9243**      **FB**  
NEW

HEIGHT	32 3/4	IN	83.2	CM
WIDTH	12 5/8	IN	32.1	CM
THICK	3/4	IN	1.9	CM
WEIGHT	9.6	LBS	4.4	KGS

**9331**      **FB**  
NEW

HEIGHT	31 7/8	IN	81.0	CM
WIDTH	9	IN	22.9	CM
THICK	1 5/8	IN	4.1	CM
WEIGHT	8.8	LBS	4.0	KGS

REVISION DATE: 12/24/94

SCALE: 1 INCH = 1 FOOT UNLESS NOTED



# Alloy Casting

## ALUMINUM CASTINGS

Toll Free (800) 527-1318

(972) 286-2368

Fax: (972) 557-4727

Section:

## Heavy Duty Castings

**826**      **DF**

HEIGHT 17 1/4 IN      43.8 CM  
 WIDTH 5 1/4 IN      13.3 CM  
 THICK 1 IN      2.5 CM  
 WEIGHT 2.6 LBS      1.2 KGS

**1836**      **DF**  
NEW

LAMB UNDER WILLOW

HEIGHT 35 3/4 IN      90.8 CM  
 WIDTH 11 IN      27.9 CM  
 THICK 1 IN      2.5 CM  
 WEIGHT 17.0 LBS      7.7 KGS

**1830**      **DF**  
NEW

30 DEG

LAMB UNDER WILLOW

HEIGHT 31 3/4 IN      80.6 CM  
 WIDTH 10 1/2 IN      26.7 CM  
 THICK 1 1/2 IN      3.8 CM  
 WEIGHT 15.0 LBS      6.8 KGS

**1822**      **DF**  
NEW

22 DEG

LAMB UNDER WILLOW

HEIGHT 32 3/8 IN      82.2 CM  
 WIDTH 10 1/2 IN      26.7 CM  
 THICK 1 1/2 IN      3.8 CM  
 WEIGHT 16.0 LBS      7.3 KGS

**9264**      **DF**  
NEW

HEIGHT 12 1/4 IN      103.2 CM  
 WIDTH 12 1/4 IN      4.8 CM  
 THICK 4 IN      4.8 CM  
 WEIGHT 10.0 LBS      4.5 KGS

**9269**      **DF**  
NEW

THIS PIECE GOES WITH SPEAR POINTS NO. 9270 AND 9275 AS SHOWN ON PAGES 81 AND 84.

HEIGHT 30 IN      76.2 CM  
 WIDTH 9 1/2 IN      24.1 CM  
 THICK 1 IN      2.5 CM  
 WEIGHT 10.0 LBS      4.5 KGS

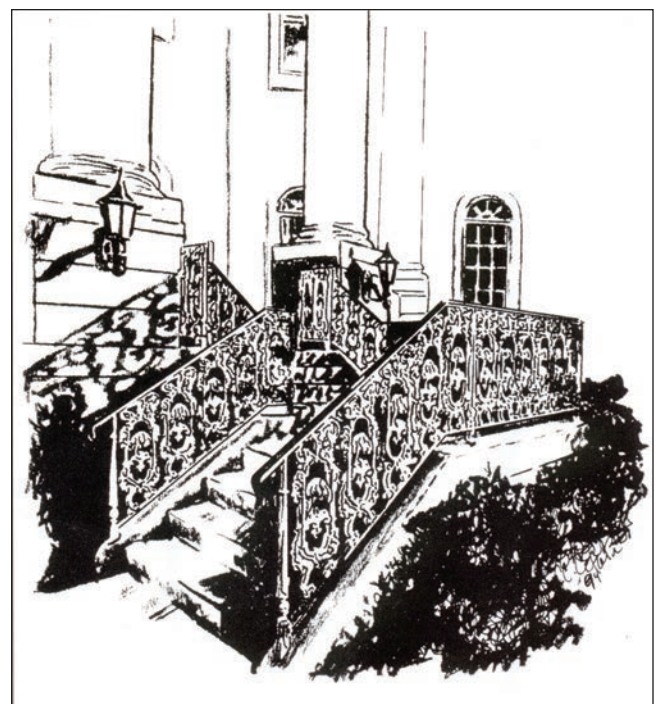

Church railings using lamb-under-willow heavy duty castings #1822, #1830, and #1836.

REVISION DATE: 01/30/95

SCALE: 1 INCH = 1 FOOT UNLESS NOTED

Section:  
Ballisters

Toll Free (800) 527-1318  
(972) 286-2368  
Fax: (972) 557-4727



ALUMINUM CASTINGS

**9193**  
NEW

BAR ENDS ARE 3/4 INCH SQUARE.

HEIGHT 42 IN	106.7 CM
WIDTH 1 1/2 IN	3.8 CM
THICK 1 1/2 IN	3.8 CM
WEIGHT 2.8 LBS	1.3 KGS

**150**  
NEW

BAR ENDS ARE 3/4 INCH DIAM.

HEIGHT 40 IN	101.6 CM
WIDTH 2 3/4 IN	7.0 CM
THICK 2 3/4 IN	7.0 CM
WEIGHT 3.5 LBS	1.6 KGS

**151**  
NEW

TOP END IS 3/4 INCH DIAM.

BOTTOM END IS 1 1/2 INCH SQUARE.

HEIGHT 40 IN	101.6 CM
WIDTH 1 1/2 IN	7.0 CM
THICK 1 1/2 IN	7.0 CM
WEIGHT 4.0 LBS	1.8 KGS

**152**  
NEW

BAR ENDS ARE 1 INCH DIAM.

HEIGHT 40 5/8 IN	103.2 CM
WIDTH 1 7/8 IN	2.2 CM
THICK 1 7/8 IN	2.2 CM
WEIGHT 3.8 LBS	3.8 KGS

**9208**  
NEW

CENTER IS 1 7/8 INCH DIAMETER.

BAR ENDS ARE 1 INCH DIAM.

HEIGHT 40 1/4 IN	102.2 CM
WIDTH 1 1/2 IN	3.8 CM
THICK 1 1/2 IN	3.8 CM
WEIGHT 4.1 LBS	1.9 KGS

**9209**  
NEW

TOP END IS ONE INCH DIAMETER.

CENTER IS 1 1/2 INCH DIAMETER.

BAR ENDS ARE 1 INCH SQUARE.

HEIGHT 40 1/4 IN	102.2 CM
WIDTH 1 7/8 IN	4.8 CM
THICK 1 7/8 IN	4.8 CM
WEIGHT 4.2 LBS	1.9 KGS

**9238**  
NEW

TOP END IS 3/4 INCH DIAMETER.

BOTTOM END IS 1 1/2 INCH SQUARE.

HEIGHT 40 1/4 IN	102.2 CM
WIDTH 1 1/2 IN	3.8 CM
THICK 1 1/2 IN	3.8 CM
WEIGHT 5.2 LBS	2.3 KGS

**9288**  
NEW

TOP END IS 3/4 INCH DIAMETER.

BOTTOM END IS 1 1/2 INCH SQUARE.

HEIGHT 43 IN	109.2 CM
WIDTH 2 IN	5.1 CM
THICK 2 IN	5.1 CM
WEIGHT 6.1 LBS	2.8 KGS

REVISION DATE: 01/20/95

SCALE: 1 INCH = 1 FOOT UNLESS NOTED



**9258**  
NEW

**DF**

1 1/4"



TWO PIECES REQUIRED FOR EACH ASSEMBLY. HOLE IS 1.6" I. D. PIECE FITS OVER NOMINAL 1 1/4 SCHED 40 PIPE.

HEIGHT	31 IN	78.7 CM
WIDTH	4 1/4 IN	10.8 CM
THICK	2 1/8 IN	5.4 CM
WEIGHT	10.2 LBS	4.7 KGS

**990**

**DF**

2"



26 1/2 INCHES LONG

HOLE IS 2 3/8" DIAMETER. PIECE FITS OVER A 2 INCH PIPE.

HEIGHT	26 1/2 IN	67.3 CM
WIDTH	6 1/2 IN	16.5 CM
THICK	6 1/2 IN	16.5 CM
WEIGHT	16.0 LBS	5.9 KGS

**998**  
NEW

**DF**

2"



28 1/2 INCHES LONG

HOLE IS 2 3/8" DIAMETER. PIECE FITS OVER A 2 INCH PIPE.

HEIGHT	28 1/2 IN	72.4 CM
WIDTH	6 1/2 IN	16.5 CM
THICK	6 1/2 IN	16.5 CM
WEIGHT	17.0 LBS	7.7 KGS

**9250**  
NEW

**DF**

STEEPLE



ALL HORIZONTAL CROSS SECTIONS OF THIS PIECE ARE CIRCLES.

HEIGHT	26 1/4 IN	66.7 CM
WIDTH	7 IN	17.8 CM
THICK	5 1/2 IN	14.0 CM
WEIGHT	2.3 LBS	1.0 KGS

**9260**  
NEW

**DF**

END DIAMETERS ARE 1 1/4 INCHES



CENTER AND MAX DIAMETER IS 1 1/4 INCHES.

END DIAMETERS ARE 1 1/4 INCHES

HEIGHT	22 1/2 IN	57.2 CM
WIDTH	1 1/8 IN	2.9 CM
THICK	1 1/8 IN	2.9 CM
WEIGHT	1.1 LBS	0.5 KGS

REVISION DATE: 01/20/95

SCALE: 1 INCH = 1 FOOT UNLESS NOTED

Section:  
Rosettes

Toll Free (800) 527-1318  
(972) 286-2368  
Fax: (972) 557-4727



**9245** **FB**  
NEW

HEIGHT 3 3/4 IN 9.5 CM  
WIDTH 3 3/4 IN 9.5 CM  
THICK 5/8 IN 1.6 CM  
WEIGHT 0.6 LBS 0.3 KGS

**8102** **FB**  
OLD 2R

HEIGHT 4 IN 9.5 CM  
WIDTH 4 IN 9.5 CM  
THICK 1/2 IN 1.3 CM  
WEIGHT 0.3 LBS 0.1 KGS

**8103** **FB**  
OLD 3R

HEIGHT 2 5/8 IN 6.7 CM  
WIDTH 2 5/8 IN 6.7 CM  
THICK 3/8 IN 1.0 CM  
WEIGHT 0.1 LBS 0.05 KGS

**8106** **FB**  
OLD 6R

HEIGHT 3 3/4 IN 9.5 CM  
WIDTH 3 3/4 IN 9.5 CM  
THICK 5/8 IN 1.6 CM  
WEIGHT 0.3 LBS 0.1 KGS

**8108** **FB**  
OLD 8R

HEIGHT 7 1/2 IN 19.0 CM  
WIDTH 4 1/2 IN 11.4 CM  
THICK 1/2 IN 1.3 CM  
WEIGHT 0.2 LBS 0.1 KGS

**8109** **FB**  
OLD 9R

HEIGHT 6 1/2 IN 16.5 CM  
WIDTH 4 IN 10.2 CM  
THICK 3/8 IN 1.0 CM  
WEIGHT 0.2 LBS 0.1 KGS

**8110** **FB**  
OLD 10R

HEIGHT 2 1/8 IN 5.4 CM  
WIDTH 2 1/8 IN 5.4 CM  
THICK 3/8 IN 1.0 CM  
WEIGHT 0.1 LBS 0.04 KGS

**8111** **FB**  
OLD 11R

HEIGHT 2 1/4 IN 5.7 CM  
WIDTH 2 1/4 IN 5.7 CM  
THICK 3/16 IN 0.5 CM  
WEIGHT 0.06 LBS 0.03 KGS

**8118** **FB**  
OLD 18R

HEIGHT 2 IN 5.1 CM  
WIDTH 2 IN 5.1 CM  
THICK 1/4 IN 0.6 CM  
WEIGHT 0.06 LBS 0.03 KGS

**8125** **FB**  
OLD 25R

HEIGHT 2 3/8 IN 6.0 CM  
WIDTH 2 3/8 IN 6.0 CM  
THICK 1/4 IN 0.6 CM  
WEIGHT 0.1 LBS 0.03 KGS

**8114** **FB**  
OLD 14R

HEIGHT 6 IN 15.2 CM  
WIDTH 6 IN 15.2 CM  
THICK 1 1/8 IN 2.9 CM  
WEIGHT 0.8 LBS 0.3 KGS

**9246** **FB**  
NEW

HEIGHT 7 1/4 IN 18.4 CM  
WIDTH 3 IN 7.6 CM  
THICK 3/4 IN 1.9 CM  
WEIGHT 0.4 LBS 0.2 KGS

REVISION DATE: 03/28/95

SCALE: 3 INCHES = 1 FOOT UNLESS NOTED

**8122** **FB**  
NEW



HEIGHT 2 3/4 IN 7.0 CM  
WIDTH 2 3/4 IN 7.0 CM  
THICK 1/4 IN 0.6 CM  
WEIGHT 0.1 LBS 0.04 KGS

**8115** **FB**  
OLD 15R

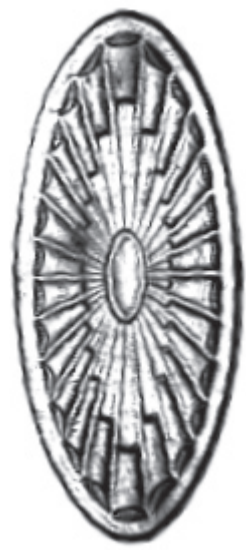

HEIGHT 11 5/8 IN 29.5 CM  
WIDTH 5 IN 12.7 CM  
THICK 3/8 IN 1.0 CM  
WEIGHT 0.8 LBS 0.4 KGS

**8116** **FB**  
OLD 16R

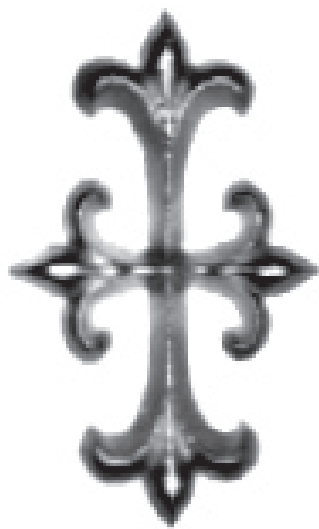

HEIGHT 11 1/4 IN 28.6 CM  
WIDTH 7 3/4 IN 9.7 CM  
THICK 3/4 IN 1.9 CM  
WEIGHT 1.2 LBS 0.6 KGS

**8107** **FB**  
OLD 7R



HEIGHT 3 IN 7.6 CM  
WIDTH 3 IN 7.6 CM  
THICK 1/4 IN 0.6 CM  
WEIGHT 0.1 LBS 0.05 KGS

**8119** **FB**  
OLD 19R



HEIGHT 3 1/8 IN 7.9 CM  
WIDTH 3 1/8 IN 7.9 CM  
THICK 1/4 IN 0.6 CM  
WEIGHT 0.6 LBS 0.2 KGS

**8124** **FB**  
NEW



HEIGHT 2 1/8 IN 5.4 CM  
WIDTH 2 1/8 IN 5.4 CM  
THICK 1/4 IN 0.6 CM  
WEIGHT 0.1 LBS 0.04 KGS

**8117** **SF**  
OLD 17R

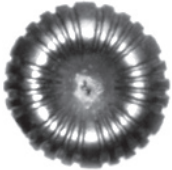

HEIGHT 3 1/2 IN 8.9 CM  
WIDTH 3 1/2 IN 8.9 CM  
THICK 5/8 IN 1.6 CM  
WEIGHT 0.2 LBS 0.1 KGS

**8126** **FB**  
NEW



HEIGHT 2 1/2 IN 6.4 CM  
WIDTH 1 7/8 IN 4.8 CM  
THICK 3/16 IN 0.5 CM  
WEIGHT 0.03 LBS 0.01 KGS

**8127** **FB**  
NEW



HEIGHT 4 IN 10.2 CM  
WIDTH 3 1/8 IN 7.9 CM  
THICK 1/2 IN 1.3 CM  
WEIGHT 0.2 LBS 0.1 KGS

**8120** **FB**  
OLD 20R



HEIGHT 6 5/8 IN 16.8 CM  
WIDTH 5 3/8 IN 13.6 CM  
THICK 3/4 IN 1.9 CM  
WEIGHT 0.5 LBS 0.2 KGS

**8128** **FB**  
NEW



NOT TO SCALE  
HEIGHT 9 IN 22.9 CM  
WIDTH 6 7/8 IN 17.5 CM  
THICK 7/8 IN 2.2 CM  
WEIGHT 1.2 LBS 0.5 KGS



**NEW**  
 FLAT BACK



**8131**  
 HEIGHT 7 1/4"  
 WIDTH: 4 3/8"  
 THICK: 5/8"  
 WEIGHT: .5 lbs

**NEW**  
 FLAT BACK



**8132**  
 HEIGHT 8 7/8"  
 WIDTH: 7 3/8"  
 THICK: 1/2"  
 WEIGHT: 1.0 lbs

**NEW**  
 FLAT BACK



**8188**  
 HEIGHT 7"  
 WIDTH: 4"  
 THICK: 3/8"  
 WEIGHT: .2 lbs

**NEW**  
 FLAT BACK



**4421**  
 HEIGHT 4.5"  
 WIDTH: 3 7/8"  
 THICK: 1/4"  
 WEIGHT: .15 lbs

**NEW**  
 FLAT BACK



**8149**  
 HEIGHT 1 7/8" dia  
 WIDTH: 1 7/8" dia  
 THICK: 1/4"  
 WEIGHT: .2 lbs

**NEW**  
 FLAT BACK



**9069**  
 HEIGHT 2 3/8" dia  
 WIDTH: 2 3/8" dia  
 THICK: 3/8"  
 WEIGHT: .1 lbs

**NEW**  
 DOUBLE FACE



**8137**  
 HEIGHT 3 1/8" dia  
 WIDTH: 3 1/8" dia  
 THICK: 3/8"  
 WEIGHT: .2 lbs

**NEW**  
 DOUBLE FACE



SEE THROUGH

**8170**  
 HEIGHT 3 1/8" dia  
 WIDTH: 3 1/8" dia  
 THICK: 1/4"  
 WEIGHT: .15 lbs

**NEW**  
 FLAT BACK



**8144**  
 HEIGHT 6 1/8"  
 WIDTH: 2 7/8"  
 THICK: 1/2"  
 WEIGHT: .4 lbs

**NEW**  
 DOUBLE FACE



**8112**  
 HEIGHT 4" dia  
 WIDTH: 4" dia  
 THICK: 1 1/8"  
 WEIGHT: .8 lbs

**NEW**  
 DOUBLE FACE



**8152**  
 HEIGHT 8 7/8" dia  
 WIDTH: 8 7/8" dia  
 THICK: 3/4"  
 WEIGHT: 1.2 lbs

**NEW**  
 FLAT BACK



**8182**  
 HEIGHT 3 3/8"  
 WIDTH: 2 1/8"  
 THICK: 3/8"  
 WEIGHT: .1 lbs





# ALLOY CASTING

Aluminum

Toll Free (800) 527-1318

(972) 286-2368

Fax (972) 557-4727

## ROSETTES

**NEW**

FLAT BACK



DESIGN MATCHES  
#848 & #849

**8277**

HEIGHT 4 1/2"  
WIDTH: 4 1/2"  
THICK: 1/2"  
WEIGHT: 0.5 lbs

**NEW**

FLAT BACK



**9070**

HEIGHT 8"  
WIDTH: 10"  
THICK: 5/8"  
WEIGHT: 3.0 lbs

**NEW**

FLAT BACK



**1904**

HEIGHT 4 1/4"  
WIDTH: 2 1/2"  
THICK: 3/8"  
WEIGHT: 0.1 lbs

**NEW**

FLAT BACK



**8145**

HEIGHT 6" dia  
WIDTH: 6" dia  
THICK: 1/2"  
WEIGHT: 1.0 lbs

**NEW**

HOLLOW BACK



**9302**

HEIGHT 4 3/4" dia  
WIDTH: 4 3/4" dia  
THICK: 1/8"  
WEIGHT: 0.4 lbs

**NEW**

DOUBLE FACE



**9495**

HEIGHT 10 1/2" dia  
WIDTH: 10 1/2" dia  
THICK: 1 1/2"  
WEIGHT: 5.5 lbs

**NEW**

FLAT BACK



2 PC SET. LEFT & RIGHT

**8136/8139**

HEIGHT 3 1/2" dia  
WIDTH: 3 1/2" dia  
THICK: 3/4"  
WEIGHT: .8 lbs/pr

**NEW**

DOUBLE FACE



**4416**

HEIGHT 7 3/4"  
WIDTH: 7 3/4"  
THICK: 7/8"  
WEIGHT: 4.8 lbs

**NEW**

FLAT BACK



BUTTON ROSETTE

**8148**

HEIGHT 2 3/8" dia  
WIDTH: 2 3/8" dia  
THICK: 3/4"  
WEIGHT: 0.2 lbs

**NEW**

FLAT BACK



**3761**

HEIGHT 6 1/4"  
WIDTH: 8 1/4"  
THICK: 1"  
WEIGHT: 1.4 lbs

**NEW**

FLAT BACK



MATCHES CENTERS  
#920 & #922

**8133**

HEIGHT 3 5/8"  
WIDTH: 3 7/8"  
THICK: 3/4"  
WEIGHT: 0.4 lbs

**NEW**

DOUBLE FACE



**9845**

HEIGHT 3 5/8"  
WIDTH: 3 1/8"  
THICK: 1 1/8"  
WEIGHT: 1.0 lbs

SEE OTHER SEA  
SHELLS ON PAGE 132

**3704** **FB**  
NEW



HEIGHT	7 5/8 IN	19.4 CM
WIDTH	5 1/2 IN	17.8 CM
THICK	3/8 IN	1.0 CM
WEIGHT	0.7 LBS	0.3 KGS

**3709** **FB**  
NEW



HEIGHT	16 1/8 IN	41.0 CM
WIDTH	6 1/2 IN	16.5 CM
THICK	3/8 IN	1.0 CM
WEIGHT	0.6 LBS	0.3 KGS

**3705** **FB**  
NEW



HEIGHT	14 7/8 IN	37.8 CM
WIDTH	9 1/2 IN	24.1 CM
THICK	3/8 IN	1.0 CM
WEIGHT	1.0 LBS	0.5 KGS

**3706** **FB**  
NEW



HEIGHT	14 7/8 IN	37.8 CM
WIDTH	9 1/2 IN	24.1 CM
THICK	3/8 IN	1.0 CM
WEIGHT	1.0 LBS	0.5 KGS

**SET**

DO NOT MATCH UP  
BACK TO BACK. SEE  
DOUBLE FACE #9437

**3702** **FB**  
NEW



HEIGHT	23 IN	58.4 CM
WIDTH	13 3/4 IN	34.9 CM
THICK	5/8 IN	1.6 CM
WEIGHT	3.2 LBS	1.4 KGS

**3703** **FB**  
NEW

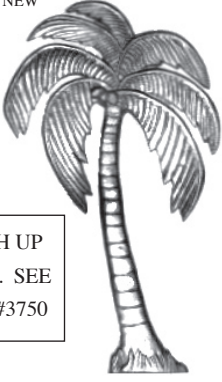

HEIGHT	23 IN	58.4 CM
WIDTH	13 3/4 IN	34.9 CM
THICK	5/8 IN	1.6 CM
WEIGHT	3.2 LBS	1.4 KGS

**SET**

DO NOT MATCH UP  
BACK TO BACK. SEE  
DOUBLE FACE #3750

**3707** **FB**  
NEW



HEIGHT	7 1/2 IN	19.0 CM
WIDTH	5 IN	12.7 CM
THICK	3/8 IN	1.2 CM
WEIGHT	0.3 LBS	0.1 KGS

**3708** **FB**  
NEW



HEIGHT	7 1/2 IN	19.0 CM
WIDTH	5 IN	12.7 CM
THICK	3/8 IN	1.2 CM
WEIGHT	0.3 LBS	0.1 KGS

**SET**

**3711** **FB**  
NEW



HEIGHT	15 3/8 IN	39.1 CM
WIDTH	5 1/2 IN	14.0 CM
THICK	3/8 IN	1.0 CM
WEIGHT	0.9 LBS	0.4 KGS

**3712** **FB**  
NEW



HEIGHT	15 3/8 IN	39.1 CM
WIDTH	5 1/2 IN	14.0 CM
THICK	3/8 IN	1.0 CM
WEIGHT	0.9 LBS	0.4 KGS

**SET**

**3725** **FB**  
NEW



HEIGHT	19 1/4 IN	48.9 CM
WIDTH	20 3/4 IN	52.7 CM
THICK	3 1/2 IN	8.9 CM
WEIGHT	47.0 LBS	21.4 KGS



# Alloy Casting

## ALUMINUM CASTINGS



Toll Free (800) 527-1318

(972) 286-2368

Fax: (972) 557-4727

Section:

Plaques

<b>3730</b> NEW 	<b>FB</b>	<b>3731</b> NEW 	<b>FB</b>
<b>SET</b>			
NOTE: EACH PIECE HAS TWO TABS WITH A 1/8 INCH HOLE FOR SCREW ON APPLICATIONS.			
HEIGHT 16 1/2 IN WIDTH 7 1/2 IN THICK 1 IN WEIGHT 1.2 LBS	41.9 CM 19.0 CM 2.5 CM 0.6 KGS	HEIGHT 16 1/2 IN WIDTH 7 1/2 IN THICK 1 IN WEIGHT 1.2 LBS	41.9 CM 19.0 CM 2.5 CM 0.6 KGS

<b>3732</b> NEW 	<b>FB</b>
<b>SET</b>	
SCALE: 3 INCHES = 1 FOOT	
HEIGHT 8 7/8 IN WIDTH 9 1/2 IN THICK 3/4 IN WEIGHT 0.5 LBS	22.5 CM 24.1 CM 1.9 CM 0.2 KGS

<b>3733</b> NEW 	<b>FB</b>
<b>SET</b>	
SCALE: 3 INCHES = 1 FOOT	
HEIGHT 6 1/4 IN WIDTH 9 1/4 IN THICK 3/4 IN WEIGHT 0.4 LBS	15.9 CM 23.5 CM 1.9 CM 0.2 KGS

<b>3727</b> NEW 	<b>SBO</b>
HEIGHT 12 1/4 IN WIDTH 30 1/2 IN THICK 1 1/4 IN WEIGHT 6.8 LBS	31.1 CM 77.5 CM 1.2 CM 3.1 KGS

<b>3734</b> NEW 	<b>SBO</b>
HEIGHT 8 1/8 IN WIDTH 11 1/2 IN THICK 1 IN WEIGHT 0.9 LBS	20.6 CM 29.2 CM 2.5 CM 0.4 KGS

<b>9281</b> NEW 	<b>DF</b>
HEIGHT 10 3/4 IN WIDTH 10 3/4 IN THICK 5/8 IN WEIGHT 4.8 LBS	27.3 CM 27.3 CM 2.5 CM 2.2 KGS

<b>7732</b> NEW 	<b>FB</b>
HEIGHT 8 1/4 IN WIDTH 23 3/4 IN THICK 7/8 IN WEIGHT 2.9 LBS	21.0 CM 60.3 CM 2.2 CM 1.3 KGS

<b>3726</b> NEW 	<b>SBO</b>
LION HEAD	
SCALE: 6 INCHES = 1 FOOT	
HEIGHT 7 3/4 IN WIDTH 7 IN THICK 2 3/4 IN WEIGHT 1.8 LBS	19.7 CM 17.8 CM 7.0 CM 0.8 KGS

<b>892</b> 	<b>FB</b>
HEIGHT 14 1/4 IN WIDTH 12 1/8 IN THICK 5/8 IN WEIGHT 6.2 LBS	36.2 CM 30.8 CM 1.6 CM 2.8 KGS

<b>7737</b> NEW 	<b>FB</b>
HEIGHT 7 1/2 IN WIDTH 7 1/2 IN THICK 3/4 IN WEIGHT 2.2 LBS	CM 44.4 19.0 1.9 1.0 KGS

REVISION DATE: 12/26/94

SCALE: 1 INCH = 1 FOOT UNLESS NOTED

Section:  
**Plaques:**  
**Eagle Castings**

Toll Free (800) 527-1318  
 (972) 286-2368  
 Fax: (972) 557-4727



**61** **SBO**



HEIGHT 7 IN	17.8 CM
WIDTH 16 3/8 IN	41.6 CM
THICK 1 IN	2.5 CM
WEIGHT 0.8 LBS	0.4 KGS

**62** **SBO**



HEIGHT 5 1/2 IN	14.0 CM
WIDTH 19 1/2 IN	49.5 CM
THICK 2 7/8 IN	7.3 CM
WEIGHT 1.2 LBS	0.6 KGS

**63** **SBO**



HEIGHT 9 3/4 IN	24.8 CM
WIDTH 27 1/2 IN	69.8 CM
THICK 2 5/8 IN	6.7 CM
WEIGHT 3.2 LBS	1.4 KGS

**64** **SBO**

NEW



NOTE: SCALE IS 1 INCH = 1 FOOT

HEIGHT 36 1/4 IN	92.1 CM
WIDTH 39 1/2 IN	100.3 CM
THICK 2 IN	5.1 CM
WEIGHT 32.4 LBS	14.7 KGS

**8412** **DF**

NEW



HEIGHT 5 5/8 IN	14.3 CM
WIDTH 5 5/8 IN	14.3 CM
THICK 5/8 IN	1.6 CM
WEIGHT 0.5 LBS	0.2 KGS

**8413** **DF**

NEW



HEIGHT 5 5/8 IN	14.3 CM
WIDTH 5 5/8 IN	14.3 CM
THICK 5/8 IN	1.6 CM
WEIGHT 0.5 LBS	0.2 KGS





# Alloy Casting

ALUMINUM CASTINGS

Toll Free (800) 527-1318

(972) 286-2368

Fax: (972) 557-4727

Section:

Plaques:  
Western

**36**                      **SBO**

HEIGHT 17	IN	43.2	CM
WIDTH 12	IN	30.5	CM
THICK 5/8	IN	1.6	CM
WEIGHT 2.6	LBS	1.2	KGS

**3735**                      **SBO**  
NEW

HEIGHT 13 1/4	IN	33.7	CM
WIDTH 16 3/4	IN	42.5	CM
THICK 3/4	IN	1.9	CM
WEIGHT 4.0	LBS	1.8	KGS

**7715**                      **SBO**  
NEW

**NOT AVAILABLE**

HEIGHT 21 1/2	IN	33.7	CM
WIDTH 13	IN	42.5	CM
THICK 4	IN	1.9	CM
WEIGHT 3.4	LBS	1.5	KGS

**7739**                      **SBO**  
NEW

HEIGHT 11	IN	27.9	CM
WIDTH 8 5/8	IN	21.9	CM
THICK 2 1/2	IN	6.4	CM
WEIGHT 1.5	LBS	0.7	KGS

**8412**                      **DF**  
NEW

HEIGHT 5 5/8	IN	14.3	CM
WIDTH 5 5/8	IN	14.3	CM
THICK 1/2	IN	1.3	CM
WEIGHT 0.6	LBS	0.2	KGS

**8413**                      **DF**  
NEW

HEIGHT 5 5/8	IN	14.3	CM
WIDTH 5 5/8	IN	14.3	CM
THICK 1/2	IN	1.3	CM
WEIGHT 0.6	LBS	0.2	KGS

**8402**                      **FB**  
NEW

HEIGHT 5 5/8	IN	14.3	CM
WIDTH 5 5/8	IN	14.3	CM
THICK 1/2	IN	1.3	CM
WEIGHT 0.6	LBS	0.2	KGS

**8405**                      **FB**  
NEW

HEIGHT 5 5/8	IN	14.3	CM
WIDTH 5 5/8	IN	14.3	CM
THICK 1/2	IN	1.3	CM
WEIGHT 0.6	LBS	0.2	KGS

**2510**                      **FB**  
NEW

**ZIA**

HEIGHT 10	IN	25.4	CM
WIDTH 10	IN	25.4	CM
THICK 5/8	IN	1.6	CM
WEIGHT 1.3	LBS	0.6	KGS

**2511**                      **FB**  
NEW

**ZIA**

HEIGHT 11 3/8	IN	28.9	CM
WIDTH 11 3/8	IN	28.9	CM
THICK 5/8	IN	1.6	CM
WEIGHT 1.4	LBS	0.6	KGS

**2518**                      **FB**  
NEW

**ZIA**

HEIGHT 17 7/8	IN	45.4	CM
WIDTH 17 7/8	IN	45.4	CM
THICK 5/8	IN	1.6	CM
WEIGHT 2.4	LBS	1.1	KGS

**8569**                      **FB**  
NEW

**MARSHALL'S BADGE**

NOTE: THIS ITEM NOT TO SCALE.

HEIGHT 21 1/4	IN	54.0	CM
WIDTH 21 1/4	IN	54.0	CM
THICK 1/2	IN	1.3	CM
WEIGHT 11.5	LBS	5.2	KGS

REVISION DATE: 01/21/95

SCALE: 1 INCH = 1 FOOT UNLESS NOTED

Section:

Toll Free (800) 527-1318

Plaques/  
Mail Box Signs

(972) 286-2368

Fax: (972) 557-4727



**171** **FB**  
NEW

HEIGHT 23 IN 58.4 CM  
WIDTH 6 IN 15.2 CM  
THICK 3/4 IN 2.2 CM  
WEIGHT 2.6 LBS 1.2 KGS

**172** **FB**  
NEW

HEIGHT 23 3/4 IN 60.3 CM  
WIDTH 6 1/8 IN 15.6 CM  
THICK 3/4 IN 1.9 CM  
WEIGHT 2.6 LBS 1.2 KGS

**173** **FB**  
NEW

HEIGHT 23 IN 58.4 CM  
WIDTH 6 1/4 IN 15.9 CM  
THICK 3/4 IN 1.9 CM  
WEIGHT 2.5 LBS 1.1 KGS

**170** **FB**  
NEW

HEIGHT 2 1/2 IN 5.4 CM  
WIDTH SCALE IN SCALE CM  
THICK 3/8 IN 1.0 CM  
WEIGHT 0.3 LBS 0.2 KGS

**82** **2"**  
NEW

HORSES HEAD, TWO PIECES  
REQUIRED. FITS OVER A 2 INCH  
OUTSIDE DIAMETER TUBE. PIECES  
MAY BE WELDED TOGETHER

DATA BELOW IS FOR EACH PIECE

HEIGHT 11 IN 27.9 CM  
WIDTH 8 1/2 IN 21.6 CM  
THICK 1 1/2 IN 3.8 CM  
WEIGHT 0.8 LBS 0.4 KGS

**1088** **DF**  
NEW

MAIL BOX SIGN

HEIGHT 8 1/2 IN 21.6 CM  
WIDTH 16 1/2 IN 41.9 CM  
THICK 1 5/8 IN 4.1 CM  
WEIGHT 2.5 LBS 1.2 KGS

**2088** **DF**  
NEW

MAIL BOX SIGN

HEIGHT 12 1/8 IN 30.8 CM  
WIDTH 16 IN 40.6 CM  
THICK 1 5/8 IN 4.1 CM  
WEIGHT 2.5 LBS 1.2 KGS

**3088** **DF**  
NEW

MAIL BOX SIGN

HEIGHT 12 IN 30.5 CM  
WIDTH 19 3/4 IN 50.2 CM  
THICK 1 1/2 IN 3.8 CM  
WEIGHT 3.9 LBS 1.8 KGS

REVISION DATE: 01/21/95

SCALE: 1 INCH = 1 FOOT UNLESS NOTED

**3713** **FB**  
NEW



HEIGHT 4 5/8 IN 11.4 CM  
WIDTH 30 IN 76.2 CM  
THICK 3/16 IN 0.5 CM  
WEIGHT 1.0 LBS 0.4 KGS

**3714** **FB**  
NEW



HEIGHT 8 3/4 IN 22.2 CM  
WIDTH 21 3/4 IN 55.2 CM  
THICK 3/16 IN 0.5 CM  
WEIGHT 0.9 LBS 0.4 KGS

**3715** **FB**  
NEW



HEIGHT 4 5/8 IN 11.4 CM  
WIDTH 20 1/4 IN 51.1 CM  
THICK 5/16 IN 0.8 CM  
WEIGHT 0.5 LBS 0.2 KGS

**3716** **FB**  
NEW



HEIGHT 6 1/8 IN 15.6 CM  
WIDTH 19 3/4 IN 50.2 CM  
THICK 3/16 IN 0.5 CM  
WEIGHT 0.8 LBS 0.3 KGS

**3717** **FB**  
NEW



HEIGHT 6 5/8 IN 16.8 CM  
WIDTH 20 IN 50.8 CM  
THICK 3/8 IN 0.1 CM  
WEIGHT 1.1 LBS 0.5 KGS

**3718** **FB**  
NEW



HEIGHT 2 1/4 IN 6.9 CM  
WIDTH 20 IN 50.8 CM  
THICK 3/16 IN 0.5 CM  
WEIGHT 0.5 LBS 0.2 KGS

**3719** **FB**  
NEW



HEIGHT 4 IN 10.1 CM  
WIDTH 16 3/8 IN 41.6 CM  
THICK 3/16 IN 0.5 CM  
WEIGHT 0.2 LBS 0.01 KGS

**3720** **FB**  
NEW



HEIGHT 6 1/8 IN 15.6 CM  
WIDTH 15 IN 38.1 CM  
THICK 3/16 IN 0.5 CM  
WEIGHT 0.5 LBS 0.2 KGS

**3721** **FB**  
NEW



HEIGHT 2 1/8 IN 5.6 CM  
WIDTH 15 1/8 IN 38.4 CM  
THICK 3/16 IN 0.5 CM  
WEIGHT 0.3 LBS 0.1 KGS

**3722** **FB**  
NEW



HEIGHT 2 1/4 IN 5.7 CM  
WIDTH 13 IN 33.0 CM  
THICK 3/16 IN 0.5 CM  
WEIGHT 0.2 LBS 0.1 KGS

**3723** **FB**  
NEW



HEIGHT 1 3/8 IN 3.5 CM  
WIDTH 13 1/8 IN 33.3 CM  
THICK 1/8 IN 0.3 CM  
WEIGHT 0.2 LBS 0.1 KGS

**3724** **FB**  
NEW



HEIGHT 1 1/2 IN 3.8 CM  
WIDTH 9 3/4 IN 24.8 CM  
THICK 1/8 IN 0.3 CM  
WEIGHT 0.1 LBS 0.05 KGS

Section:  
Star Castings

Toll Free (800) 527-1318  
(972) 286-2368  
Fax: (972) 557-4727



**8121** FB  
NEW

HEIGHT 8 3/4 IN 22.2CM  
WIDTH 9 1/8 IN 23.2CM  
THICK 5/8 IN 1.6CM  
WEIGHT 0.5 LBS 0.2 KGS

**9244** FB  
NEW

HEIGHT 7 1/8 IN 18.1 CM  
WIDTH 7 IN 17.8 CM  
THICK 1 1/4 IN 3.2 CM  
WEIGHT 0.8 LBS 0.4 KGS

**8108** FB  
OLD 8R

HEIGHT 7 1/2 IN 19.0CM  
WIDTH 4 1/2 IN 11.4 CM  
THICK 1/2 IN 1.3 CM  
WEIGHT 0.2 LBS 0.1KGS

**8402** FB  
NEW

HEIGHT 5 5/8 IN 14.3 CM  
WIDTH 5 5/8 IN 14.3 CM  
THICK 1/2 IN 1.3 CM  
WEIGHT 0.6 LBS 0.2 KGS

**711** NEW FB  
**11 5/8 IN. DIA**

**712** NEW  
**2 FT DIA**

**713** NEW  
**3 FT DIA**

**714** NEW  
**4 FT DIA**

NO SCALE

CATALOG NO	DIA. IN	DIA. CM	THICK IN	THICK CM	WT LBS	KGS
711	11 5/8	29.5	1	2.5	4.3	2.0
712	24	61.0	2	5.1	35.0	15.9
713	36	91.4	3	7.6	135.0	61.4
714	48	121.9	4	10.2	300.0	136.4

**8569** FB  
NEW

SCALE: 1 INCH = 1 FOOT

HEIGHT 21 1/4 IN 54.0 CM  
WIDTH 21 1/4 IN 54.0 CM  
THICK 1/2 IN 1.3 CM  
WEIGHT 11.5 LBS 5.2 KGS

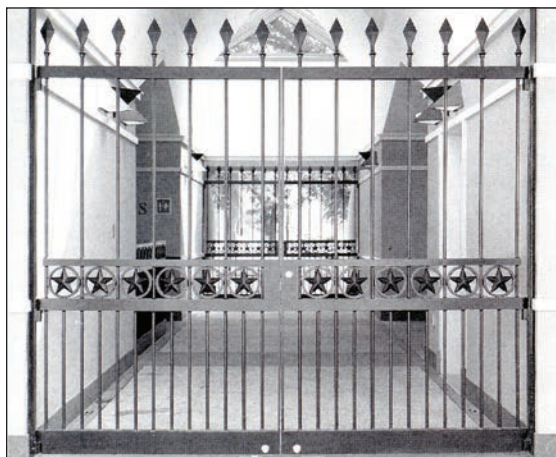

Circle star #9237 and spear point #8211 custom designed and made for the White House Visitors center, Washington, D.C.

REVISION DATE: 12/27/94

**9237** DF  
NEW

THIS PIECE WAS USED WITH CATALOG NUMBER 8211 AT THE VISITORS CENTER, THE WHITE HOUSE, WASHINGTON, D.C.

HEIGHT 6 3/4 IN 17.1 CM  
WIDTH 6 3/4 IN 17.1 CM  
THICK 1 1/4 IN 3.2 CM  
WEIGHT 2.3 LBS 1.0 KGS

**932** DF  
NEW

INQUIRE

SCALE: 1 IN = 1 FOOT

HEIGHT 28 5/8 IN 72.7 CM  
WIDTH 14 IN 35.6 CM  
THICK 5/8 IN 1.6 CM  
WEIGHT 5.2 LBS 2.4 KGS

SCALE : 3 INCHES = 1 FOOT UNLESS NOTED





# Alloy Casting

## ALUMINUM CASTINGS

Toll Free (800) 527-1318

(972) 286-2368

Fax: (972) 557-4727

Section:

Letters

**545A Through 545Z** **FB**

**5** Inch Letters

NEW

ABCD

HEIGHT	5	IN	12.7	CM
AVE WIDTH	4	IN	10.2	CM
THICK	1/2	IN	1.3	CM
AVE WEIGHT	0.7	LB	0.32	KG

**548A Through 548Z** **FB**

**8** Inch Letters

NEW

ABCD

HEIGHT	8	IN	20.3	CM
AVE WIDTH	6 3/4	IN	17.1	CM
THICK	1/2	IN	1.3	CM
AVE WEIGHT	1.0	LB	0.45	KG

**540A Through 540Z** **FB**

**10** Inch Letters

NEW

ABCD

HEIGHT	10	IN	25.4	CM
AVE WIDTH	6 1/8	IN	15.6	CM
THICK	1/2	IN	1.3	CM
AVE WEIGHT	1.4	LB	0.64	KG

**564A Through 564Z** **FB**

**4** Inch "Old English" Letters

NEW

ABCD

NOT AVAILABLE

HEIGHT	4	IN	10.2	CM
AVE WIDTH	5/8	IN	15.6	CM
THICK	3/16	IN	1.3	CM
AVE WEIGHT	0.5	LB	0.2	KG

**560A Through 560Z** **FB**

**10** Inch "Old English" Letters

NEW

ABCD

HEIGHT	10	IN	25.4	CM
AVE WIDTH	7	IN	15.6	CM
THICK	3/16	IN	1.3	CM
AVE WEIGHT	1.0	LB	0.64	KG

**NOTE:** WHEN ORDERING ITEMS FROM THIS PAGE USE THE FIRST CATALOG NUMBERS TO INDICATE SIZE AND STYLE AND THE LAST LETTER TO INDICATE THE SPECIFIC LETTER DESIRED.

FOR EXAMPLE; TO ORDER A LETTER "G" THAT IS 10 INCHES TALL AND OLD ENGLISH DESIGN, TAKE THE BASE CATALOG NUMBER 560 AND ADD THE LETTER "G". THEN THE CATALOG NUMBER FOR THAT PIECE WOULD BE 560G.

REVISION DATE: 12/27/94

SCALE 1 INCH = 1 FOOT

Section:  
Numbers

Toll Free (800) 527-1318  
(972) 286-2368  
Fax: (972) 557-4727



5440 Through 5449

FB

**4** Inch Numbers

NEW



HEIGHT	4	IN	10.2	CM
AVE WIDTH	4	IN	10.2	CM
THICK	1/2	IN	1.3	CM
AVE WEIGHT	0.7	LB	0.3	KG

5490 Through 5499

FB

**8** Inch Numbers

NEW



HEIGHT	8	IN	20.3	CM
AVE WIDTH	5	IN	12.7	CM
THICK	1/4	IN	0.6	CM
AVE WEIGHT	0.2	LB	0.09	KG

5450 Through 5459

FB

**5** Inch Numbers

NEW



HEIGHT	5	IN	12.7	CM
AVE WIDTH	4	IN	10.2	CM
THICK	7/16	IN	1.1	CM
AVE WEIGHT	0.5	LB	0.2	KG

5400 Through 5409

FB

**10** Inch Numbers

NEW



HEIGHT	10	IN	25.4	CM
AVE WIDTH	6 1/8	IN	15.6	CM
THICK	1/2	IN	1.3	CM
AVE WEIGHT	1.2	LB	0.55	KG

5480 through 5489

FB

**8** Inch Numbers

NEW



HEIGHT	8 1/8	IN	20.6	CM
AVE. WIDTH	6 1/8	IN	15.6	CM
THICK	1/2	IN	1.3	CM
WEIGHT	0.4	LB	0.2	KG

**NOTE:** WHEN ORDERING ITEMS FROM THIS PAGE USE THE FIRST CATALOG NUMBERS TO INDICATE SIZE AND STYLE AND THE LAST NUMBER TO INDICATE THE SPECIFIC NUMBER DESIRED.

FOR EXAMPLE; TO ORDER A NUMBER "EIGHT" THAT IS 10 INCHES TALL, TAKE THE BASE NUMBER 548 AND ADD THE DIGET 8. THEN THE CATALOG NUMBER FOR THAT PIECE WOULD BE 5488.

REVISION DATE: 01/30/95

SCALE 1 INCH = 1 FOOT



# Alloy Casting

## ALUMINUM CASTINGS

Toll Free (800) 527-1318

(972) 286-2368

Fax: (972) 557-4727

Section:

Numbers

6800 Through 6809

FB

4

Inch Numbers

NEW

1234

HEIGHT	3 7/8 IN	9.8 CM
AVE WIDTH	3 7/8 IN	9.8 CM
THICK	1/4 IN	0.6 CM
AVE WEIGHT	0.1 LB	0.04 KG

**NOTE:** WHEN ORDERING ITEMS FROM THIS PAGE USE THE FIRST CATALOG NUMBERS TO INDICATE SIZE AND STYLE AND THE LAST NUMBER TO INDICATE THE SPECIFIC NUMBER DESIRED.

FOR EXAMPLE; TO ORDER A NUMBER "EIGHT" THAT IS 3 INCHES TALL, TAKE THE BASE NUMBER 680 AND ADD THE DIGET 8. THEN THE CATALOG NUMBER FOR THAT PIECE WOULD BE 6808.

REVISION DATE: 01/30/95

SCALE 1 INCH = 1 FOOT

Section:  
**Flanges:  
 Round Hole**

Toll Free (800) 527-1318  
 (972) 286-2368  
 Fax: (972) 557-4727



**9194**  
 NEW

1"

TOP VIEW  
 SIDE VIEW

HOLE IS 1 IN. DIAMETER. PROFILE MATCHES NUMBER 9218 FOUND ON PAGE 75.

HEIGHT 2 1/2 IN	10.0 CM
WIDTH 2 1/2 IN	10.0 CM
THICK 7/8 IN	2.2 CM
WEIGHT 0.2 LBS	0.1 KGS

**8580**  
 OLD 58

1 1/2"  
 PIPE

HOLE IS 1 1/16 IN. DIAMETER

HEIGHT 3 7/8 IN	10.2 CM
WIDTH 3 7/8 IN	10.2 CM
THICK 7/8 IN	2.2 CM
WEIGHT 0.3 LBS	0.2 KGS

**8582**  
 NEW

1 1/2"  
 PIPE

HOLE IS 1 1/16 IN. DIAMETER. HOLES ON FLANGE ARE 3/16 IN. DIAMETER.

HEIGHT 3 7/8 IN	10.2 CM
WIDTH 3 7/8 IN	10.2 CM
THICK 7/8 IN	2.2 CM
WEIGHT 0.3 LBS	0.2 KGS

**8590**  
 NEW

2"

HOLE IS 2 IN. DIAMETER.

HEIGHT 3 3/4 IN	9.5 CM
WIDTH 3 3/4 IN	9.5 CM
THICK 3/4 IN	1.9 CM
WEIGHT 0.3 LBS	0.1 KGS

**8540**  
 OLD 54

2 1/4"

HOLE IS 2 1/4 INCHES IN DIAMETER. BOSS IS 3/4 INCHES DEEP

HEIGHT 4 IN	10.2 CM
WIDTH 4 IN	10.2 CM
THICK 7/8 IN	2.2 CM
WEIGHT 0.6 LBS	0.3 KGS

**8533**  
 NEW

1 7/8"

HOLE IS 1 7/8 INCHES IN DIAMETER.

HEIGHT 3 7/8 IN	9.8 CM
WIDTH 3 7/8 IN	9.8 CM
THICK 1 7/8 IN	5.1 CM
WEIGHT 0.6 LBS	0.3 KGS

**134**

2"

HOLE IS 2 IN. DIAMETER. THIS PIECE WITH 137 MAY BE USED AS A PAIR. SEE SKETCH ON PAGE NO. 79.

NOTE: THIS PIECE NOT TO SCALE

HEIGHT 4 1/2 IN	12.1 CM
WIDTH 4 IN	10.2 CM
THICK 1 1/4 IN	3.2 CM
WEIGHT 0.6 LBS	0.2 KGS

**135**

3"

HOLE IS 3 IN. DIAMETER. THIS PIECE WITH 138 MAY BE USED AS A PAIR. SEE SKETCH ON PAGE NO. 79.

NOTE: THIS PIECE NOT TO SCALE

HEIGHT 5 3/4 IN	14.6 CM
WIDTH 5 3/4 IN	14.6 CM
THICK 1 3/8 IN	3.5 CM
WEIGHT 0.6 LBS	0.3 KGS

**8560**  
 OLD 56

3"

HOLE IS 3 IN. IN DIAMETER.

HEIGHT 4 IN	10.2 CM
WIDTH 4 IN	10.2 CM
THICK 1 1/2 IN	3.8 CM
WEIGHT 0.5 LBS	0.2 KGS

**8570**  
 OLD 57

4"

INSIDE HOLE IS 4 IN. DIAMETER.

HEIGHT 8 IN	20.3 CM
WIDTH 5 5/8 IN	14.3 CM
THICK 1 IN	2.5 CM
WEIGHT 1.3 LBS	0.6 KGS

REVISION DATE: 01/21/95

SCALE: 3 INCHES = 1 FOOT UNLESS NOTED





# ALLOY CASTING

Aluminum

Toll Free (800) 527-1318

(972) 286-2368

Fax (972) 557-4727

# FLANGES

## SQUARE HOLE 1/2", 5/8" & 3/4"

**NEW**

V TYPE 1/2" □



HOLE IS 1/2" X 1/2" SQUARE / FLAT BOTTOM

**8451**

HEIGHT 2"  
WIDTH: 2"  
THICK: 1/2"  
WEIGHT: .1 lbs

**NEW**

A TYPE 1/2" □

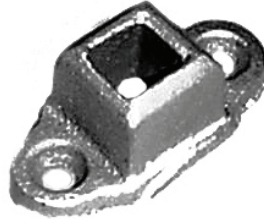

HOLE IS 1/2" X 1/2" SQUARE

**4803**

HEIGHT 2 3/8"  
WIDTH: 1 1/4"  
THICK: 7/8"  
WEIGHT: .1 lbs

A TYPE 1/2" □

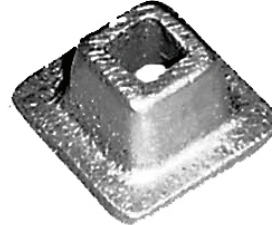

HOLE IS 1/2" X 1/2" SQUARE

**8450**

HEIGHT 1 3/4"  
WIDTH: 1 3/4"  
THICK: 1"  
WEIGHT: .1 lbs

HEIGHT  
WIDTH:  
THICK:  
WEIGHT:

**NEW**

S TYPE 5/8" □

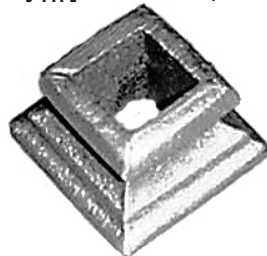

HOLE IS 5/8" X 5/8" SQUARE

**1652**

HEIGHT 1 1/2"  
WIDTH: 1 1/2"  
THICK: 1"  
WEIGHT: .1 lbs

HEIGHT  
WIDTH:  
THICK:  
WEIGHT:

**NEW**

A TYPE 3/4" □



HOLE IS 3/4" X 3/4" SQUARE

**8906**

HEIGHT 2 1/2"  
WIDTH: 2 1/2"  
THICK: 1/2"  
WEIGHT: .2 lbs

**NEW**

A TYPE 3/4" □



HOLE IS 3/4" X 3/4" SQUARE

**8460**

HEIGHT 2"  
WIDTH: 3 7/8"  
THICK: 1"  
WEIGHT: .2 lbs



A type tight at top



S type straight walls



V type tight at bottom

**FLANGES  
SQUARE HOLE 1"**

Toll Free (800) 527-1318  
(972) 286-2368  
Fax (972) 557-4727

**ALLOY CASTING**

Aluminum



**NEW**

A TYPE 1" □

HOLE IS 1" X 1" SQUARE

**8610**

HEIGHT: 3"  
WIDTH: 3"  
THICK: 1"  
WEIGHT: 0.3 lbs

V TYPE 1" □

HOLE IS 1" X 1" SQUARE  
BOLT DOWN HOLE TAPERS  
DOWN TO 3/16" IN DIA.

**8471**

HEIGHT 2 5/8"  
WIDTH: 2 5/8"  
THICK: 1/2"  
WEIGHT: .1 lbs

V TYPE 1" □

HOLE IS 1" X 1" SQUARE  
HEAVY DUTY CASTING  
TAPPED HOLE 1 1/8"  
OPENING AT TOP, 1" OPENING  
AT BOTTOM

**8425**

HEIGHT 3 5/8"  
WIDTH: 3 5/8"  
THICK: 2"  
WEIGHT: .3 lbs

A TYPE 1" □

HOLE IS 1" X 1" SQUARE

**8430**

HEIGHT 2 3/8"  
WIDTH: 2 3/8"  
THICK: 1"  
WEIGHT: .1 lbs

A TYPE 1" □

HOLE IS 1" X 1" SQUARE

**8421**

HEIGHT 3 3/4"  
WIDTH: 1 3/4"  
THICK: 1 3/8"  
WEIGHT: .2 lbs

A TYPE 1" □

HOLE IS 1" X 1" SQUARE

**4774**

HEIGHT 2 1/8"  
WIDTH: 2 1/8"  
THICK: 1 1/4"  
WEIGHT: 0.20 lbs

**NEW**

V TYPE 1" □

HOLE IS 1" X 1" SQUARE

**8472**

HEIGHT 3 1/4"  
WIDTH: 3 1/4"  
THICK: 5/8"  
WEIGHT: 0.35 lbs

A TYPE 1" □

HOLE IS 1" X 1" SQUARE

**8470**

HEIGHT 2 3/4"  
WIDTH: 2 3/4"  
THICK: 1"  
WEIGHT: .2 lbs

**NEW**

A TYPE □

HOLE IS 1" X 1" SQUARE

**2023**

HEIGHT  
WIDTH:  
THICK:  
WEIGHT:

A TYPE 1" □

HOLE IS 1" X 1" SQUARE  
PROFILE MATCH #9194

**9218**

HEIGHT 2 1/2"  
WIDTH: 2 1/2"  
THICK: 7/8"  
WEIGHT: .2 lbs

A TYPE 1" □

HOLE IS 1" X 1" SQUARE

**8420**

HEIGHT 2 3/4"  
WIDTH: 1 3/4"  
THICK: 1 1/4"  
WEIGHT: .2 lbs

**NEW**

A TYPE 1" □

HOLE IS 1" X 1" SQUARE

**8426**

HEIGHT  
WIDTH:  
THICK:  
WEIGHT:



# ALLOY CASTING

Aluminum

Toll Free (800) 527-1318  
(972) 286-2368  
Fax (972) 557-4727

# FLANGES SQUARE HOLE 1 1/4"

**NEW**

DRIVE IN SHOE  
FOR 1" SQUARE 1" ■



TOP IS 5/8" SQUARE

**8424**

HEIGHT 2"  
WIDTH: 1 1/8"  
THICK: 1 1/4"  
WEIGHT: .1 lbs

**NEW**

DRIVE IN SHOE  
FOR 1" SQUARE 1" ■



TOP IS 3/4" SQUARE

**8423**

HEIGHT 2 5/8"  
WIDTH: 2 5/8"  
THICK: 1/2"  
WEIGHT: .1 lbs

**NEW**

A TYPE 1 1/4" □



HOLE IS 1 1/4" X 1 1/4"  
SQUARE

**8480**

HEIGHT 3"  
WIDTH: 3"  
THICK: 1 1/4"  
WEIGHT: .3 lbs

**NEW**

V TYPE 1 1/4" □

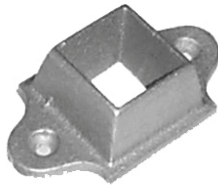

HOLE IS 1 1/4" X 1 1/4"  
SQUARE

**8489**

HEIGHT 4 3/4"  
WIDTH: 2 5/8"  
THICK: 1 1/4"  
WEIGHT: 0.35 lbs

**NEW**

A TYPE 1 1/4" □

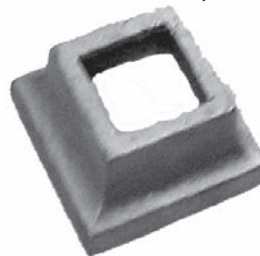

HOLE IS 1 1/4" X 1 1/4"  
SQUARE

**8487**

HEIGHT 1 1/4"  
WIDTH: 3"  
THICK: 3"  
WEIGHT: 0.3 lbs

V TYPE 1 1/4" □

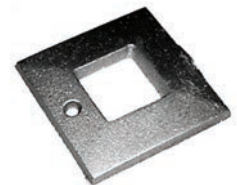

HOLE IS 1 1/4" X 1 1/4"  
SQUARE  
BOLT DOWN HOLE TAPERS  
DOWNTWO 3/16" IN DIA.

**8481**

HEIGHT 3 1/4"  
WIDTH: 3 1/4"  
THICK: 1/4"  
WEIGHT: .1 lbs

**NEW**

V TYPE 1 1/4" □



HOLE IS 1 1/4" X 1 1/4"  
SQUARE

**8488**

HEIGHT 3 3/4"  
WIDTH: 2 5/8"  
THICK: 1 1/4"  
WEIGHT: 0.2 lbs



A type tight at top



S type straight walls



V type tight at bottom

**FLANGES**  
**SQUARE HOLE 1 1/2"**

Toll Free (800) 527-1318  
(972) 286-2368  
Fax (972) 557-4727

**ALLOY CASTING**

Aluminum



**NEW**  
A TYPE 1 1/2" □

HOLE IS 1 1/2" X 1 1/2" SQUARE

**8912**  
HEIGHT 3 7/8"  
WIDTH: 3 7/8"  
THICK: 5/8"  
WEIGHT: .2 lbs

**NEW**  
A TYPE 1 1/2" □

HOLE IS 1 1/2" X 1 1/2" SQUARE

**4773**  
HEIGHT 4 3/4"  
WIDTH: 3 3/8"  
THICK: 1 5/8"  
WEIGHT: .45 lbs

**NEW** IN DEVELOPMENT  
A TYPE 1 1/2" □

HOLE IS 1 1/2" X 1 1/2" SQUARE

**2495**  
HEIGHT 3 3/4"  
WIDTH: 2 3/4"  
THICK: 1 3/8"  
WEIGHT: .3 lbs

**NEW**  
A TYPE 1 1/2" □

HOLE IS 1 1/2" X 1 1/2" SQUARE

**2496**  
HEIGHT 4 5/8"  
WIDTH: 2 3/4"  
THICK: 1 3/8"  
WEIGHT: .35 lbs

**NEW**  
V TYPE 1 1/2" □

HOLE IS 1 1/2" X 1 1/2" SQUARE

**9915**  
HEIGHT 3"  
WIDTH: 3"  
THICK: 1/2"  
WEIGHT: .10 lbs

V TYPE 1 1/2" □

HOLE IS 1 1/2" X 1 1/2" SQUARE

**8490**  
HEIGHT 3 1/2"  
WIDTH: 3 1/2"  
THICK: 1"  
WEIGHT: .3 lbs

V TYPE 1 1/2" □

HOLE IS 1 1/2" X 1 1/2" SQUARE

**495**  
HEIGHT 3 5/8"  
WIDTH: 2 1/2"  
THICK: 1 1/4"  
WEIGHT: .3 lbs

**NEW**  
V TYPE 1 1/2" □

HOLE IS 1 1/2" X 1 1/2" SQUARE

**8496**  
HEIGHT 4 5/8"  
WIDTH: 2 5/8"  
THICK: 1 1/4"  
WEIGHT: .3 lbs

V TYPE 1 1/2" □

HOLE IS 1 1/2" X 1 1/2" SQUARE

**8491**  
HEIGHT 3 1/2"  
WIDTH: 3 1/2"  
THICK: 1/4"  
WEIGHT: .2 lbs

**NEW**  
V TYPE 1 1/2" □  
HOLES 1/4" IN DIA.

HOLE IS 1 1/2" X 1 1/2" SQUARE

**1417**  
HEIGHT 4 1/8"  
WIDTH: 4 1/8"  
THICK: 1 3/4"  
WEIGHT: .6 lbs

**NEW** IN DEVELOPMENT  
A TYPE 1 1/2" □

HOLE IS 1 1/2" X 1 1/2" SQUARE

**498**  
HEIGHT 3 7/8"  
WIDTH: 3 7/8"  
THICK: 1 3/4"  
WEIGHT: .4 lbs

A TYPE 1 1/2" □  
HOLES 1/4" IN DIA.

HOLE IS 1 1/2" X 1 1/2" SQUARE

**8497**  
HEIGHT 3 7/8"  
WIDTH: 3 7/8"  
THICK: 3/4"  
WEIGHT: .3 lbs





# ALLOY CASTING

Aluminum

Toll Free (800) 527-1318

(972) 286-2368

Fax (972) 557-4727

## FLANGES

### SQUARE HOLE 1 1/2" & 2"

V TYPE 1.5" □

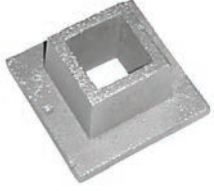

HEAVY DUTY PIECE  
HAS TAPERED HOLE 1 5/8"  
OPENING AT TOP 1 1/2"  
OPENING AT BOTTOM

**8498**

HEIGHT	4 1/8"
WIDTH:	4 1/8"
THICK:	2"
WEIGHT:	1.1 lbs

V TYPE 2" □



HOLE IS 2" X 2" SQUARE

**8509**

HEIGHT	3 3/4"
WIDTH:	3 3/4"
THICK:	1/4"
WEIGHT:	.25 lbs

**NEW**

A TYPE 2" □



HOLE IS 2" X 2" SQUARE

**8620**

HEIGHT	4 3/8"
WIDTH:	4 3/8"
THICK:	2"
WEIGHT:	.7 lbs

**NEW**

A TYPE 2" □



HOLE IS 2" BY 2" SQUARE

**8501**

HEIGHT	5 1/8"
WIDTH:	5 1/8"
THICK:	1 3/4"
WEIGHT:	1.1 lbs

**NEW**

V TYPE 2" □

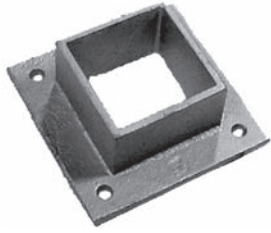

HOLE IS 2" BY 2" SQUARE

**1421**

HEIGHT	4"
WIDTH:	4"
THICK:	1 1/2"
WEIGHT:	.5 lbs

V TYPE 2" □

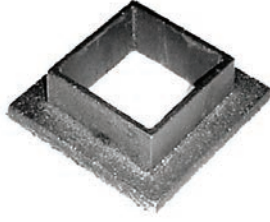

HOLE IS 2" X 2" SQUARE

**8508**

HEIGHT	3 3/4"
WIDTH:	3 3/4"
THICK:	1 1/4"
WEIGHT:	.4 lbs

V TYPE 2" □



HOLE IS 2" X 2" SQUARE

**8507**

HEIGHT	4 3/4"
WIDTH:	4 3/4"
THICK:	3/4"
WEIGHT:	.5 lbs

A TYPE 2" □

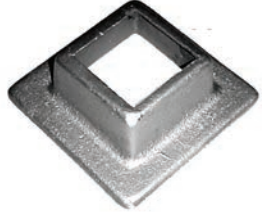

HOLE IS 2" X 2" SQUARE

**8500**

HEIGHT	4 3/4"
WIDTH:	4 3/4"
THICK:	1 5/8"
WEIGHT:	.5 lbs

**NEW**

V TYPE 2" □



HOLE IS 2" X 2" SQUARE

**1420**

HEIGHT	4 7/8"
WIDTH:	3"
THICK:	1 5/8"
WEIGHT:	.45 lbs

**NEW**

A TYPE 2" □



HOLE IS 2" X 2" SQUARE  
LOW PROFILE COVER SHOE  
FOR 1/4" THICK PLATE

**8510**

HEIGHT	5 1/8"
WIDTH:	5 1/8"
THICK:	7/8"
WEIGHT:	.5 lbs

**NEW**

V TYPE 2" □



HOLE IS 2" X 2" SQUARE

**1401**

HEIGHT	4 5/8"
WIDTH:	3 7/8"
THICK:	1 1/2"
WEIGHT:	.35 lbs

**NEW**

V TYPE 2" □



HOLE IS 2" X 2" SQUARE

**8505**

HEIGHT	4 5/8"
WIDTH:	3 3/4"
THICK:	1 1/2"
WEIGHT:	.70 lbs

**FLANGES**  
**SQUARE HOLE 2 1/2" & 3"**

Toll Free (800) 527-1318  
 (972) 286-2368  
 Fax (972) 557-4727

**ALLOY CASTING**

Aluminum



**NEW**  
 A TYPE 2 1/2" □

HOLE IS 2 1/2" X 2 1/2" SQUARE

**8725**

HEIGHT 5 3/8"  
 WIDTH: 5 3/8"  
 THICK: 3/4"  
 WEIGHT: .6 lbs

**NEW**  
 V TYPE 2 1/2" □

HOLE IS 2 1/2" X 2 1/2" SQUARE

**8625**

HEIGHT 4 7/8"  
 WIDTH: 4 7/8"  
 THICK: 2"  
 WEIGHT: .9 lbs

HEIGHT  
 WIDTH:  
 THICK:  
 WEIGHT:

HEIGHT  
 WIDTH:  
 THICK:  
 WEIGHT:

HEIGHT  
 WIDTH:  
 THICK:  
 WEIGHT:

HEIGHT  
 WIDTH:  
 THICK:  
 WEIGHT:

HEIGHT  
 WIDTH:  
 THICK:  
 WEIGHT:

HEIGHT  
 WIDTH:  
 THICK:  
 WEIGHT:

**NEW**  
 V TYPE 3" □

HOLE IS 3 1/4" X 3 1/4" SQUARE

**1416**

HEIGHT 4"  
 WIDTH: 4"  
 THICK: 2"  
 WEIGHT: .9 lbs

**NEW**  
 V TYPE 3" □

HOLE IS 3 1/4" X 3 1/4" SQUARE

**1423**

HEIGHT 6"  
 WIDTH: 4"  
 THICK: 1 5/8"  
 WEIGHT: .6 lbs

V TYPE 3" □

HOLE IS 3" X 3" SQUARE

**137**

HEIGHT 5 1/2"  
 WIDTH: 4 1/2"  
 THICK: 1 1/2"  
 WEIGHT: .55 lbs

HEIGHT  
 WIDTH:  
 THICK:  
 WEIGHT:



# ALLOY CASTING

Aluminum

Toll Free (800) 527-1318

(972) 286-2368

Fax (972) 557-4727

# FLANGES

## SQUARE HOLE 4", 5 1/2" & 6"

**HEIGHT**  
**WIDTH:**  
**THICK:**  
**WEIGHT:**

**HEIGHT**  
**WIDTH:**  
**THICK:**  
**WEIGHT:**

**V TYPE** 4" □

**HOLE IS 4" X 4" SQUARE**

**138**

**HEIGHT** 6 7/8"  
**WIDTH:** 5 1/2"  
**THICK:** 1 3/8"  
**WEIGHT:** .9 lbs

**NEW**

**A TYPE** 4" □

**HOLE IS 4" X 4" SQUARE  
FLANGE 1" WIDE**

**9840**

**HEIGHT** 7 3/8"  
**WIDTH:** 7 3/8"  
**THICK:** 2 1/2"  
**WEIGHT:** 2.6 lbs

**HEIGHT**  
**WIDTH:**  
**THICK:**  
**WEIGHT:**

**HEIGHT**  
**WIDTH:**  
**THICK:**  
**WEIGHT:**

**HEIGHT**  
**WIDTH:**  
**THICK:**  
**WEIGHT:**

**HEIGHT**  
**WIDTH:**  
**THICK:**  
**WEIGHT:**

**HEIGHT**  
**WIDTH:**  
**THICK:**  
**WEIGHT:**

**NEW**

**V TYPE** 6" □

**HOLE IS 6" X 6" SQUARE**

**1921**

**HEIGHT** 9 1/8"  
**WIDTH:** 7 1/2"  
**THICK:** 1"  
**WEIGHT:** 2.2 lbs

**HEIGHT**  
**WIDTH:**  
**THICK:**  
**WEIGHT:**

**A type tight at top**

**S type straight walls**

**V type tight at bottom**



V TYPE



SEE PROFILES OF OPENINGS ON PAGE 75H

**8021**

HEIGHT 3 5/8"  
 WIDTH: 2 3/8"  
 THICK: 1"  
 WEIGHT: .15 lbs

**NEW**

V TYPE



SEE PROFILES OF OPENINGS ON PAGE 75H

**8038**

HEIGHT 3 1/8"  
 WIDTH: 3"  
 THICK: 1"  
 WEIGHT: .3 lbs

**NEW**

V TYPE



SEE PROFILES OF OPENINGS ON PAGE 75H

**8044**

HEIGHT 3"  
 WIDTH: 4 1/2"  
 THICK: 1"  
 WEIGHT: .3 lbs

**NEW**

V TYPE



SEE PROFILES OF OPENINGS ON PAGE 75H

**9702**

HEIGHT 4 3/8"  
 WIDTH: 3 1/8"  
 THICK: 1 1/2"  
 WEIGHT: .45 lbs

**NEW**

A TYPE



SEE PROFILES OF OPENINGS ON PAGE 75H

**8071**

HEIGHT 3 3/8"  
 WIDTH: 3 1/4"  
 THICK: 1 1/4"  
 WEIGHT: .3 lbs

**NEW**

V TYPE



SEE PROFILES OF OPENINGS ON PAGE 75H

**8046**

HEIGHT 3 5/8"  
 WIDTH: 3 3/8"  
 THICK: 1 3/8"  
 WEIGHT: .4 lbs

**NEW**

V TYPE



SEE PROFILES OF OPENINGS ON PAGE 75H

**8034**

HEIGHT 4 5/8"  
 WIDTH: 3 1/4"  
 THICK: 1 3/8"  
 WEIGHT: .4 lbs

**NEW**

V TYPE

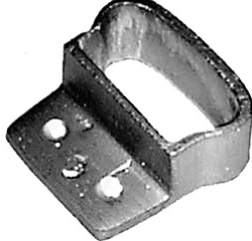

SEE PROFILES OF OPENINGS ON PAGE 75H

**8077**

HEIGHT 2 3/8"  
 WIDTH: 2 1/2"  
 THICK: 1"  
 WEIGHT: .15 lbs

**NEW**

V TYPE



SEE PROFILES OF OPENINGS ON PAGE 75H

**8078**

HEIGHT 3 1/4"  
 WIDTH: 3 1/2"  
 THICK: 1"  
 WEIGHT: .25 lbs

**NEW**

V TYPE DOUBLE FACE



1 1/2" HIGH

**8066**

HEIGHT 6 1/8"  
 WIDTH: 2 7/8"  
 THICK: 1 1/2"  
 WEIGHT: .40 lbs

**NEW**

V TYPE DOUBLE FACE



1 7/16" HIGH

**8047**

HEIGHT 4 1/2"  
 WIDTH: 3 1/2"  
 THICK: 1 7/16"  
 WEIGHT: .40 lbs

**NEW**

V TYPE DOUBLE FACE



2" HIGH

**8056**

HEIGHT 3 5/8"  
 WIDTH: 3 3/8"  
 THICK: 2"  
 WEIGHT: .60 lbs





# ALLOY CASTING

Aluminum

Toll Free (800) 527-1318

(972) 286-2368

Fax (972) 557-4727

## Hand Rail Shoe Profiles

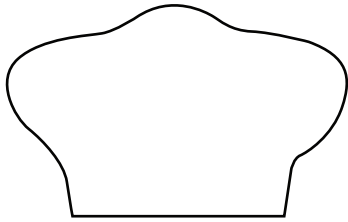

**8021**  
*V type 1" Tall*

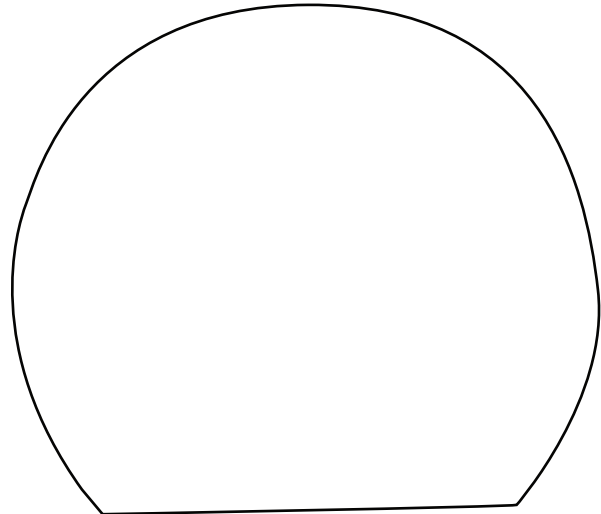

**8034**  
*V type 1 3/8" Tall*

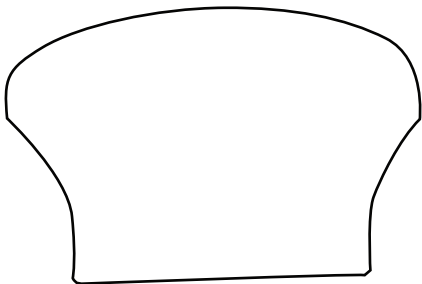

**8038**  
*V type 1 1/8" Tall*

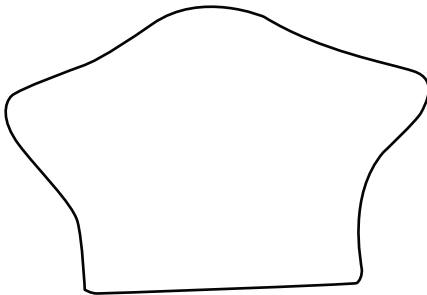

**8044** *V type 1" Tall*  
**9702** *V type 1 1/2" Tall*  
**8078** *V type 1" Tall*

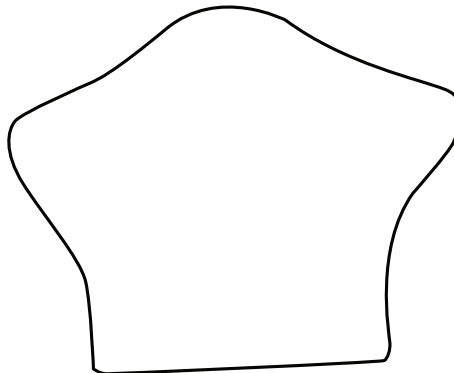

**8047**  
*V type 1 1/2" Tall*

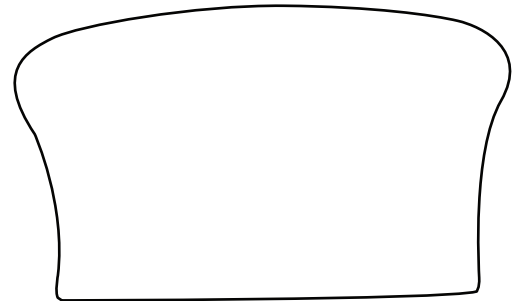

**8046** *V type 1 3/8" Tall*  
**8056** *V type 2" Tall*

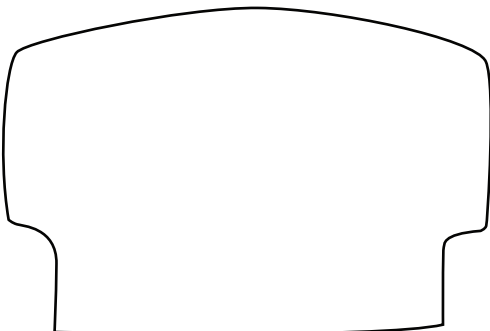

**8071**  
*A type 1 1/4" Tall*

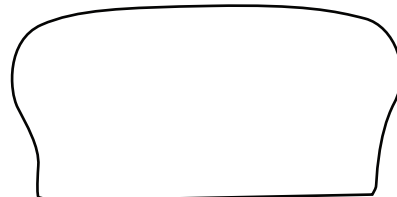

**8077**  
*V type 1" Tall*

*Reference Length  
(line to scale)*

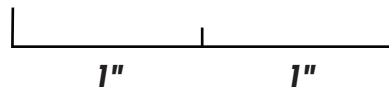

# CHANNEL SHOES

Toll Free (800) 527-1318  
 (972) 286-2368  
 Fax (972) 557-4727

## ALLOY CASTING

Aluminum



**A TYPE** 1/2" X 1" □



HOLE IS 1/2" X 1"

**8410**

HEIGHT	2"
WIDTH:	1 1/2"
THICK:	5/8"
WEIGHT:	.1 lbs

**NEW**

**A TYPE** 1/2" X 1 1/2" □



HOLE IS 1/2" X 1 1/2"

**417**

HEIGHT	2 1/2"
WIDTH:	2 1/4"
THICK:	1"
WEIGHT:	.2 lbs

**NEW**

**V TYPE** 3/4" X 1 1/2" □



HOLE IS 3/4" X 1 1/2"

**418**

HEIGHT	2 3/4"
WIDTH:	2 3/8"
THICK:	1 1/8"
WEIGHT:	.25 lbs

**NEW**

**A TYPE** 3/4" X 1 1/2" □



HOLE IS 3/4" X 1 1/2"

**428**

HEIGHT	2 3/8"
WIDTH:	2 1/4"
THICK:	7/8"
WEIGHT:	.2 lbs

**NEW**

1" X 1 1/2" □



HOLE IS 1" X 1 1/2"

**8466**

HEIGHT	6 1/8"
WIDTH:	2 1/2"
THICK:	1 1/4"
WEIGHT:	.30 lbs

**NEW**

**V TYPE** 1" X 1 1/2" □



HOLE IS 1" X 1 1/2"

**419**

HEIGHT	3"
WIDTH:	2 3/8"
THICK:	1 1/8"
WEIGHT:	.3 lbs

**NEW**

1" X 2" □



HOLE IS 1" X 2"

**8431**

HEIGHT	2 5/8"
WIDTH:	2 5/8"
THICK:	1 5/8"
WEIGHT:	.30 lbs

**NEW**

1" X 2" □

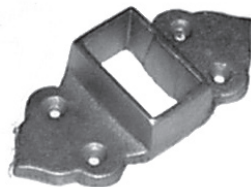

HOLE IS 1" X 2"

**8441**

HEIGHT	6 1/4"
WIDTH:	2 5/8"
THICK:	1 1/8"
WEIGHT:	.40 lbs

**NEW**

**A TYPE** 1" X 2" □



HOLE IS 1" X 2"

**8419**

HEIGHT	3 1/8"
WIDTH:	3 1/8"
THICK:	1 1/4"
WEIGHT:	.35 lbs

**NEW**

**A TYPE** 1" X 2" □



HOLE IS 1" X 2"

**8417**

HEIGHT	6 1/2"
WIDTH:	3"
THICK:	2"
WEIGHT:	1 lbs

**NEW**

**V TYPE** 1" X 2" □



HOLE IS 1" X 2"

**8401**

HEIGHT	2 3/4"
WIDTH:	2 1/8"
THICK:	1 1/4"
WEIGHT:	.25 lbs

**V TYPE** 1" X 2" □



HOLE IS 1" X 2"

**8400**

HEIGHT	4 5/8"
WIDTH:	1 1/2"
THICK:	1 1/8"
WEIGHT:	.1 lbs



# ALLOY CASTING

Aluminum

Toll Free (800) 527-1318

(972) 286-2368

Fax (972) 557-4727

# RECTANGULAR SHOES

**NEW**

V TYPE 1 3/8" X 1 5/8" □

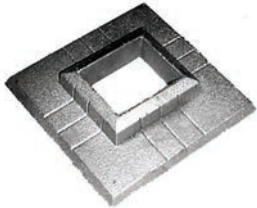

**1403**

HEIGHT: 4 1/8"  
WIDTH: 4"  
THICK: 3/4"  
WEIGHT: .35 lbs

**NEW**

V TYPE 1 1/2" X 1 3/4" □



4" X 1 1/2" HOLES

**358**

HEIGHT: 4 3/8"  
WIDTH: 4 3/8"  
THICK: 1 5/8"  
WEIGHT: .8 lbs

**NEW**

V TYPE 1 1/2" X 1 5/8" □

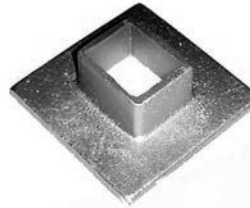

**9201**

HEIGHT: 4 5/8"  
WIDTH: 4 5/8"  
THICK: 1 1/2"  
WEIGHT: .75 lbs

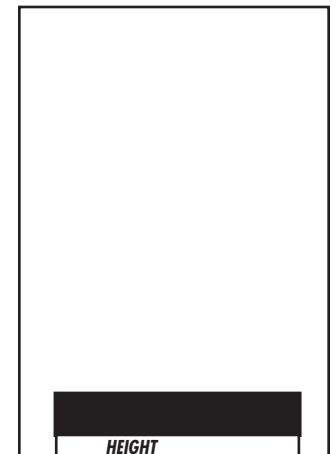

HEIGHT:  
WIDTH:  
THICK:  
WEIGHT:

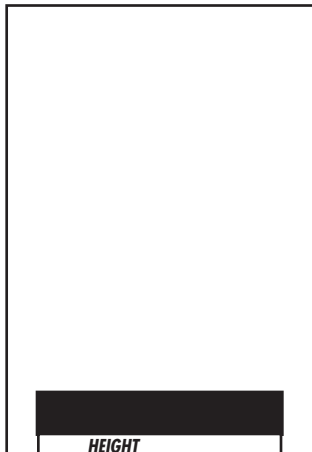

HEIGHT:  
WIDTH:  
THICK:  
WEIGHT:

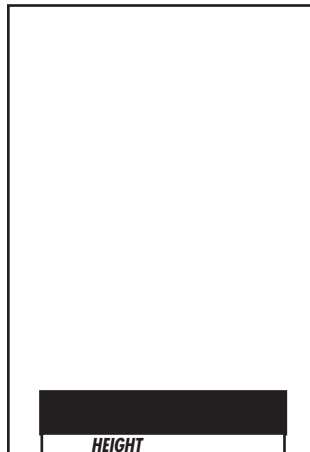

HEIGHT:  
WIDTH:  
THICK:  
WEIGHT:



HEIGHT:  
WIDTH:  
THICK:  
WEIGHT:

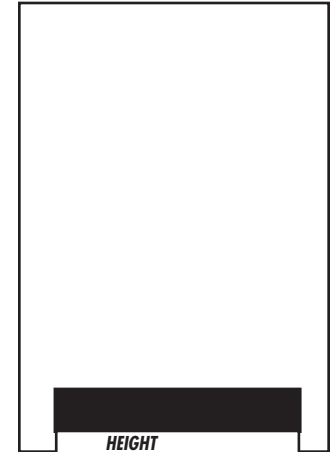

HEIGHT:  
WIDTH:  
THICK:  
WEIGHT:

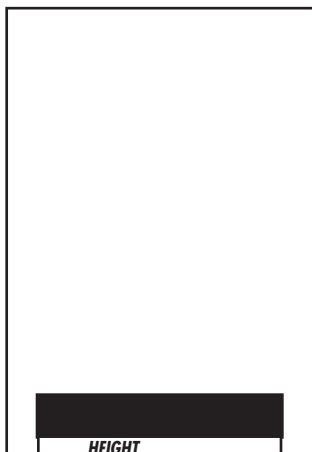

HEIGHT:  
WIDTH:  
THICK:  
WEIGHT:

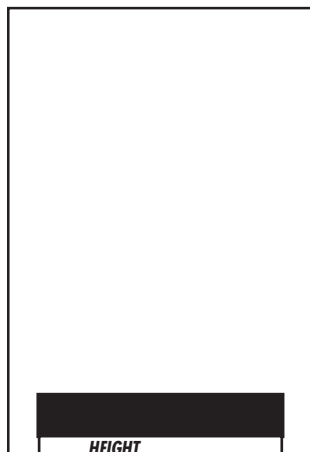

HEIGHT:  
WIDTH:  
THICK:  
WEIGHT:

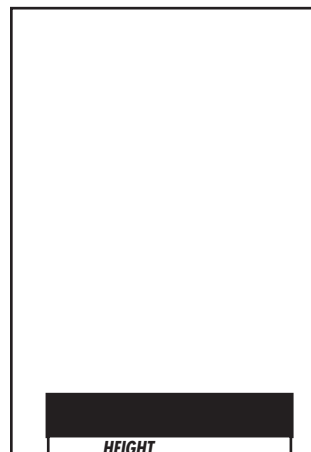

HEIGHT:  
WIDTH:  
THICK:  
WEIGHT:

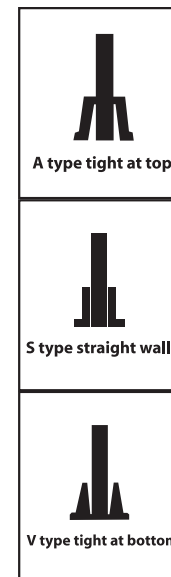

A type tight at top

S type straight walls

V type tight at bottom

Section:  
**Flanges:**  
**Square Hole**

Toll Free (800) 527-1318  
 (972) 286-2368  
 Fax: (972) 557-4727



**8480** 1 1/4"  
 OLD 48

HOLE IS 1 1/4 IN. SQUARE.

HEIGHT	3 IN	7.6 CM
WIDTH	3 IN	7.6 CM
THICK	1 1/4 IN	3.2 CM
WEIGHT	0.3 LBS	0.1 KGS

**8481** 1 1/4"  
 NEW

TOP VIEW  
 HOLE IS 1 1/4 INCH SQUARE. BOLT DOWN HOLE TAPPERS DOWN TO 3/16 INCH DIAMETER.

HEIGHT	3 1/4 IN	8.3 CM
WIDTH	3 1/4 IN	8.3 CM
THICK	1/4 IN	0.6 CM
WEIGHT	0.1 LBS	0.05 KGS

**8494** 1 1/2"  
 NEW

HOLE IS 1 1/2 IN. SQUARE.

HEIGHT	3 3/8 IN	8.6 CM
WIDTH	2 3/8 IN	6.0 CM
THICK	3/4 IN	1.9 CM
WEIGHT	0.2 LBS	0.1 KGS

**8496** 1 1/2"  
 NEW

HOLE IS 1 1/2 IN. SQUARE.

HEIGHT	3 3/8 IN	8.6 CM
WIDTH	2 3/8 IN	6.0 CM
THICK	3/4 IN	1.9 CM
WEIGHT	0.2 LBS	0.1 KGS

**8498** 1 1/2"  
 NEW

HEAVY DUTY  
 PIECE HAS A TAPORED HOLE  
 1 5/8 INCH OPENING AT TOP  
 1 1/2 INCH OPENING AT BOTTOM

HEIGHT	4 1/8 IN	10.5 CM
WIDTH	4 1/8 IN	10.5 CM
THICK	2 IN	5.1 CM
WEIGHT	1.1 LBS	0.5 KGS

**8497** 1 1/2"  
 NEW

HOLE IS 1 1/2 IN. SQUARE.

HEIGHT	3 3/4 IN	9.5 CM
WIDTH	3 3/4 IN	9.5 CM
THICK	5/8 IN	1.6 CM
WEIGHT	0.3 LBS	0.2 KGS

**8490** 1 1/2"  
 OLD 49

HOLE IS 1 1/2 IN. SQUARE.

HEIGHT	3 5/8 IN	4.4 CM
WIDTH	3 5/8 IN	4.4 CM
THICK	1 IN	2.5 CM
WEIGHT	0.3 LBS	0.1 KGS

**8491** 1 1/2"  
 NEW

TOP VIEW  
 HOLE IS 1 1/2 INCH SQUARE. BOLT DOWN HOLE TAPPERS DOWN TO 3/16 INCH DIAMETER.

HEIGHT	3 5/8 IN	4.4 CM
WIDTH	3 5/8 IN	4.4 CM
THICK	1/4 IN	0.6 CM
WEIGHT	0.2 LBS	0.07 KGS

**8500** 2"  
 OLD 50

HOLE IS 2 IN. SQUARE.

HEIGHT	4 3/4 IN	12.1 CM
WIDTH	4 3/4 IN	12.1 CM
THICK	1 5/8 IN	4.1 CM
WEIGHT	0.5 LBS	0.2 KGS

**8507** 2"  
 NEW

HOLE IS 2 IN. SQUARE.

HEIGHT	4 3/4 IN	12.1 CM
WIDTH	4 3/4 IN	12.1 CM
THICK	3/4 IN	1.9 CM
WEIGHT	0.5 LBS	0.2 KGS

**8508** 2"  
 OLD 50X8

HOLE IS 2 IN. SQUARE.

HEIGHT	3 3/4 IN	12.1 CM
WIDTH	3 3/4 IN	12.1 CM
THICK	1 1/8 IN	1.9 CM
WEIGHT	0.4 LBS	0.2 KGS

**8509** 2"  
 NEW

HOLE IS 2 INCHES SQUARE  
 SCALE: 3 INCHES = 1 FOOT

HEIGHT	3 5/8 IN	9.2 CM
WIDTH	3 5/8 IN	9.2 CM
THICK	1/4 IN	0.6 CM
WEIGHT	0.2 LBS	0.1 KGS

REVISION DATE: 01/30/95

SCALE: 1 INCH = 1 FOOT UNLESS NOTED





# Alloy Casting

## ALUMINUM CASTINGS

Toll Free (800) 527-1318

(972) 286-2368

Fax: (972) 557-4727

Section:

Finials

**8006** NEW **3/4"**

TOP VIEW  
SIDE VIEW

STUB IS 1/2 INCH LONG, AND 5/8 INCH SQUARE. SEAT IS ONE INCH SQUARE.

SCALE: 1/2 INCH = 1 INCH.

HEIGHT	1 IN	2.5 CM
WIDTH	1 IN	2.5 CM
THICK	1 IN	2.5 CM
WEIGHT	0.05 LBS	0.02 KGS

**8002** OLD 2F **1"**

TOP VIEW  
SIDE VIEW

STUB IS 3/4 INCH LONG, AND 7/8 INCH SQUARE. IT FITS INTO A 1 INCH SQUARE 16 GAGE TUBING.

SCALE: 1/2 INCH = 1 INCH.

HEIGHT	1 1/2 IN	3.8 CM
WIDTH	1 1/2 IN	3.8 CM
THICK	1 1/8 IN	2.9 CM
WEIGHT	0.1 LBS	0.04 KGS

**9267** NEW **1"**

TOP VIEW  
SIDE VIEW

STUB IS 5/8 INCH LONG, AND 7/8 INCH SQUARE. IT FITS INTO A 1 INCH SQUARE 16 GAGE TUBING.

HEIGHT	1 1/4 IN	3.2 CM
WIDTH	1 1/4 IN	3.2 CM
THICK	1 3/8 IN	3.5 CM
WEIGHT	0.2 LBS	0.07 KGS

**7726** NEW **2"**

TOP VIEW  
SIDE VIEW

HEIGHT	2 1/4 IN	5.7 CM
WIDTH	2 1/4 IN	5.7 CM
THICK	1 3/8 IN	3.5 CM
WEIGHT	0.5 LBS	0.2 KGS

**8020** NEW **1"**

SIDE VIEW. USED AS A LAMBS TOUNGE PIECE.

STUB IS 3/4 INCH SQUARE BY 3/4 INCH LONG. SEAT IS 1 1/4 INCHES SQUARE.

HEIGHT	5 IN	12.7 CM
WIDTH	3 IN	7.6 CM
THICK	1 1/4 IN	2.9 CM
WEIGHT	0.4 LBS	0.2 KGS

**8022** NEW **1 1/2"**

SIDE VIEW. USED AS A LAMBS TOUNGE PIECE.

STUB IS 1 1/4 INCH SQUARE BY 7/8 INCH LONG. SEAT IS 1 3/4 INCHES SQUARE.

HEIGHT	5 5/8 IN	14.3 CM
WIDTH	3 5/8 IN	9.2 CM
THICK	1 3/4 IN	4.4 CM
WEIGHT	0.5 LBS	0.3 KGS

**8024** NEW **1 1/4"**

SIDE VIEW. USED AS A LAMBS TOUNGE PIECE.

STUB IS 1 INCH SQUARE BY 7/8 INCH LONG. SEAT IS 1 1/2 INCHES SQUARE.

HEIGHT	5 5/8 IN	14.3 CM
WIDTH	3 5/8 IN	9.2 CM
THICK	1 3/4 IN	4.4 CM
WEIGHT	0.5 LBS	0.3 KGS

NOTE: OTHER LAMBS TOUNGE PIECES ARE ON PAGE 99. PRICES ARE IN DEVELOPMENT.

**132** **FB**

HAND RAIL END CAP

TOP VIEW  
SIDE VIEW

THIS PIECE IS 1/2 FULL SIZE.

HEIGHT	1 1/8 IN	2.9 CM
WIDTH	2 IN	5.1 CM
THICK	1/2 IN	1.3 CM
WEIGHT	0.1 LBS	0.03 KGS

**133** **FB**

HAND RAIL END CAP

TOP VIEW  
SIDE VIEW

THIS PIECE IS 1/2 FULL SIZE.

HEIGHT	1 IN	2.5 CM
WIDTH	2 5/8 IN	6.7 CM
THICK	1/2 IN	1.3 CM
WEIGHT	0.1 LBS	0.03 KGS

REVISION DATE: 01/30/95

SCALE: 3 INCHES = 1 FOOT UNLESS NOTED



ALUMINUM CASTINGS

**7713**

NEW

**3/4"**



STUB IS 3/4 INCH LONG BY 3/4 INCH SQUARE. SEAT IS 1 INCH SQUARE.

HEIGHT	3 5/8 IN	9.2 CM
WIDTH	1 1/4 IN	3.2 CM
THICK	1 1/4 IN	3.2 CM
WEIGHT	0.2 LBS	0.1 KGS

**8007**

NEW

**1"**



STUB IS 1/2 INCH LONG BY 7/8 INCHES SQUARE. SEAT IS 1 3/4 INCHES SQUARE.

HEIGHT	3 1/4 IN	8.3 CM
WIDTH	1 3/4 IN	4.4 CM
THICK	1 3/4 IN	4.4 CM
WEIGHT	0.5 LBS	0.2 KGS

**8004**

OLD 4F

**1"**



STUB IS 7/8 INCH LONG BY 7/8 INCH SQUARE. SEAT IS 1 1/4 INCHES SQUARE.

HEIGHT	4 1/4 IN	10.8 CM
WIDTH	1 3/4 IN	4.4 CM
THICK	1 3/4 IN	4.4 CM
WEIGHT	0.3 LBS	0.2 KGS

**8019**

NEW

**1"**



STUB IS 5/8 INCH LONG BY 7/8 INCHES SQUARE. SEAT IS 1 INCHES SQUARE.

HEIGHT	4 7/8 IN	12.4 CM
WIDTH	1 1/4 IN	3.2 CM
THICK	1 1/4 IN	3.2 CM
WEIGHT	0.2 LBS	0.1 KGS

**7720**

NEW

**1X2 5/8"**



END VIEW      SIDE VIEW

SEAT IS 2 5/8 INCHES BY 1 3/4 INCHES. STUB IS 1 INCH BY 2 INCHES BY 1 INCH LONG.

HEIGHT	4 3/4 IN	12.1 CM
WIDTH	2 5/8 IN	6.7 CM
THICK	1 3/4 IN	4.4 CM
WEIGHT	0.7 LBS	0.3 KGS

**7752**

NEW

**1 1/4"**



SEAT IS 1 3/4 INCHES SQUARE. STUB IS 1 1/4 INCHES SQUARE BY 3/4 INCH LONG.

HEIGHT	4 7/8 IN	12.4 CM
WIDTH	1 3/4 IN	4.4 CM
THICK	1 3/4 IN	4.4 CM
WEIGHT	0.7 LBS	0.3 KGS

**8011**

NEW

**1 1/4"**



TOP VIEW



SIDE VIEW

STUB IS 3/8 INCH LONG BY 1 1/8 INCHES SQUARE. SEAT IS 1 7/8 INCHES SQUARE.

HEIGHT	1 1/4 IN	3.2 CM
WIDTH	1 7/8 IN	4.8 CM
THICK	1 7/8 IN	4.8 CM
WEIGHT	0.2 LBS	0.1 KGS

**8008**

NEW

**1 1/4"**

AND

**1 1/2"**



TWO SQUARE STUB STEPS. BOTH STEPS ARE 1/2 INCH LONG. THE FIRST IS 1/4 BY 1 1/4 INCHES. SECOND IS 1 BY 1 INCH SQUARE. SEAT IS 1 3/4 INCHES SQUARE.

HEIGHT	3 7/8 IN	9.8 CM
WIDTH	1 3/4 IN	4.4 CM
THICK	1 3/4 IN	4.4 CM
WEIGHT	0.6 LBS	0.3 KGS

**8012**

NEW

**1 1/4"**

AND

**1 1/2"**



TWO SQUARE STUB STEPS. BOTH STEPS ARE 3/8 INCH LONG. THE FIRST IS 1 1/4 BY 1 1/4 INCHES. SECOND IS 1 BY 1 INCH SQUARE. SEAT IS 1 3/4 INCHES SQUARE.

HEIGHT	4 7/8 IN	12.4 CM
WIDTH	1 3/4 IN	4.4 CM
THICK	1 3/4 IN	4.4 CM
WEIGHT	0.5 LBS	0.2 KGS

**8009**

NEW

**1 1/2"**



TOP VIEW



SIDE VIEW

STUB IS 1/2 INCH LONG BY 1 1/4 INCHES SQUARE. SEAT IS 1 5/8 INCHES SQUARE.

HEIGHT	3 1/4 IN	8.3 CM
WIDTH	1 3/4 IN	4.4 CM
THICK	1 3/4 IN	4.4 CM
WEIGHT	0.5 LBS	0.2 KGS

**8013**

NEW

**1 1/2"**



TOP VIEW



SIDE VIEW

STUB IS 1/2 INCH LONG BY 1 3/8 INCHES SQUARE AND TAPERED. SEAT IS 1 7/8 INCHES SQUARE.

HEIGHT	1 1/8 IN	2.9 CM
WIDTH	1 3/4 IN	4.4 CM
THICK	1 3/4 IN	4.4 CM
WEIGHT	0.2 LBS	0.1 KGS

**8010**

NEW

**2 1/4"**



NOT TO SCALE

STUB IS 3/8 INCH LONG BY 2 1/8 INCHES SQUARE. SEAT IS 3 INCHES SQUARE.

HEIGHT	9 3/4 IN	24.8 CM
WIDTH	3 IN	7.6 CM
THICK	3 IN	7.6 CM
WEIGHT	2.6 LBS	1.2 KGS

134

2"



COLONIAL  
FLANGE SET

HOLE IS 2 IN. DIAMETER. THIS PIECE WITH NO. 137  
MAY BE USED AS A PAIR. SEE SKETCH TO RIGHT.

HEIGHT	4 1/2 IN	12.1 CM
WIDTH	4 IN	10.2 CM
THICK	1 1/4 IN	3.2 CM
WEIGHT	0.6 LBS	0.2 KGS

137

3"

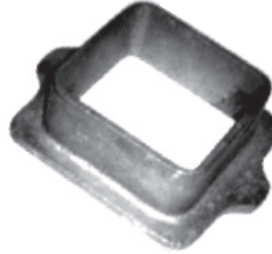

HOLE IS 3 IN. SQUARE. THIS PIECE WITH NO.134  
MAY BE USED AS A PAIR. SEE SKETCH TO RIGHT.

HEIGHT	4 1/2 IN	11.4 CM
WIDTH	5 5/8 IN	14.3 CM
THICK	1 1/2 IN	3.8 CM
WEIGHT	0.6 LBS	0.3 KGS

135

3"

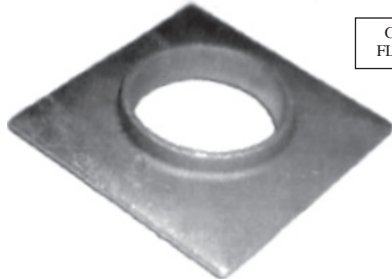

COLONIAL  
FLANGE SET

HOLE IS 3 IN. DIAMETER. THIS PIECE WITH NO.138  
MAY BE USED AS A PAIR. SEE SKETCH TO RIGHT.

HEIGHT	5 3/4 IN	14.6 CM
WIDTH	5 3/4 IN	14.6 CM
THICK	1 3/8 IN	3.5 CM
WEIGHT	1.1 LBS	0.5 KGS

138

4"

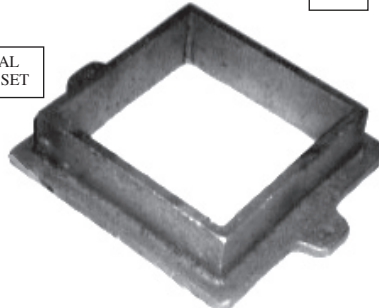

HOLE IS 4 IN. SQUARE. THIS PIECE WITH NO.135  
MAY BE USED AS A PAIR. SEE SKETCH TO RIGHT.

HEIGHT	1 1/2 IN	14.0 CM
WIDTH	6 3/4 IN	17.1 CM
THICK	4 1/2 IN	3.5 CM
WEIGHT	0.9 LBS	0.4 KGS

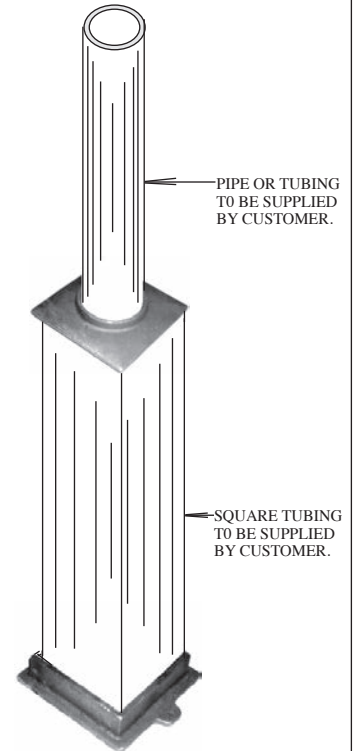

NOTE: THIS AREA NOT TO SCALE.

## COLONIAL FLANGE ASSEMBLY

(USING NO. 135 AND NO. 138)

8512

NEW

3 3/4"

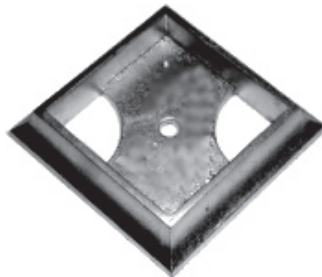

HOLE IS 3 3/4 INCHES SQUARE.  
BOSS IS 3/4 INCH DEEP.

HEIGHT	5 1/8 IN	13.0 CM
WIDTH	5 1/8 IN	13.0 CM
THICK	1 IN	2.5 CM
WEIGHT	0.8 LBS	0.4 KGS

REVISION DATE: 01/23/95

SCALE: 3 INCHES = 1 FOOT UNLESS NOTED





ALUMINUM CASTINGS

Post Caps And Hand Rail Brackets

**3301** 1"  
NEW

TOP VIEW  
SIDE VIEW

HEIGHT	1 3/8 IN	3.5 CM
WIDTH	1 3/8 IN	3.5 CM
THICK	7/8 IN	2.2 CM
WEIGHT	0.1 LBS	0.05 KGS

**3315** 1 1/2"  
NEW

INQUIRY

TOP VIEW  
SIDE VIEW

HEIGHT	1 3/4 IN	4.5 CM
WIDTH	1 3/4 IN	4.5 CM
THICK	3/4 IN	1.9 CM
WEIGHT	0.1 LBS	0.08 KGS

**3302** 2"  
NEW

TOP VIEW  
SIDE VIEW

HEIGHT	2 3/8 IN	6.0 CM
WIDTH	2 3/8 IN	6.0 CM
THICK	1 IN	2.5 CM
WEIGHT	0.2 LBS	0.1 KGS

**3325** 2 1/2"  
NEW

TOP VIEW  
SIDE VIEW

HEIGHT	3 IN	7.6 CM
WIDTH	3 IN	7.6 CM
THICK	1 IN	2.5 CM
WEIGHT	0.3 LBS	0.1 KGS

**3303** 3"  
NEW

TOP VIEW  
SIDE VIEW

HEIGHT	3 IN	7.6 CM
WIDTH	3 IN	7.6 CM
THICK	1 1/4 IN	3.2 CM
WEIGHT	0.3 LBS	0.1 KGS

**7744** 3 1/2"  
NEW

TOP VIEW  
SIDE VIEW

HEIGHT	3 7/8 IN	9.8 CM
WIDTH	3 7/8 IN	9.8 CM
THICK	1 1/2 IN	3.8 CM
WEIGHT	0.2 LBS	0.1 KGS

**3304** 4"  
NEW

INQUIRY- NOT TO SCALE

TOP VIEW  
SIDE VIEW

HEIGHT	4 1/2 IN	11.4 CM
WIDTH	4 1/2 IN	11.4 CM
THICK	1 1/2 IN	3.8 CM
WEIGHT	0.5 LBS	0.2 KGS

**9286** 2 1/2 x 5 1/4"  
NEW

TOP VIEW  
SIDE VIEW

STUB IS 1/2 INCH LONG BY 2 1/2 INCH BY 5 1/4 INCHES. SEAT IS 6 INCHES BY 3 1/8 INCHES.

HEIGHT	6 IN	15.2 CM
WIDTH	3 1/8 IN	7.9 CM
THICK	2 1/8 IN	4.5 CM
WEIGHT	0.8 LBS	0.4 KGS

**130** **DF**  
FLAT HAND RAIL BRACKET

HOLE DIAMETER IS 3/16 INCH.  
1 1/4 INCHES  
2 1/4 INCHES WALL TO CENTERLINE OF RAIL HOLES.  
HOLE DIAMETER IS 5/16 INCH.  
SCALE: 1 INCH = 3 INCHES

HEIGHT	3 IN	7.6 CM
WIDTH	2 3/8 IN	6.0 CM
THICK	2 7/8 IN	7.3 CM
WEIGHT	0.2 LBS	0.1 KGS

**131** **DF**  
CURVED HAND RAIL BRACKET

HOLE DIAMETER IS 3/16 INCH.  
1 1/4 INCHES  
2 1/4 INCHES WALL TO CENTERLINE OF RAIL HOLES.  
HOLE DIAMETER IS 7/16 INCH.  
SCALE: 1 INCH = 3 INCHES

HEIGHT	3 IN	7.6 CM
WIDTH	2 3/8 IN	6.0 CM
THICK	2 7/8 IN	7.3 CM
WEIGHT	0.2 LBS	0.1 KGS

**8021** **DF**  
OLD 21F  
TOP RAIL, WALL MOUNTED

1 1/16 INCHES  
1 3/4 INCHES  
NOTE: SCALE IS 1 INCH = 6 INCHES

HEIGHT	3 5/8 IN	9.2 CM
WIDTH	2 1/4 IN	5.7 CM
THICK	1 IN	2.5 CM
WEIGHT	0.2 LBS	0.1 KGS

REVISION DATE: 12/29/94

ON MOST POST CAPS THE TUBE OR POST WILL WEDGE FIT INTO THE CAP AND ENTER APPROXIMATELY 5/8 OF AN INCH.

SCALE: 3 INCH = 1 FOOT UNLESS NOTED





# Alloy Casting

## ALUMINUM CASTINGS

Toll Free (800) 527-1318

(972) 286-2368

Fax: (972) 557-4727

Section:

Spears,  
Plug In Type

**8262**  
NEW

**1/2"**



SEAT IS 1 1/8 INCHES SQUARE. STUB SIZE IS 15/32 INCH SQUARE AND IS OVERALL, 1 3/16 INCHES LONG.

HEIGHT	6 1/2 IN	16.5 CM
WIDTH	4 IN	10.2 CM
THICK	1 1/8 IN	2.9 CM
WEIGHT	0.3 LBS	0.1 KGS

**8212**  
NEW

**5/8"**



SEAT IS 1 1/8 INCHES SQUARE. BOTTOM STUB IS APPROXIMATELY 1/2 INCH SQ. AND IS OVERALL, 1 3/4 INCHES LONG.

HEIGHT	7 IN	17.8 CM
WIDTH	4 IN	10.2 CM
THICK	1 1/8 IN	2.9 CM
WEIGHT	0.3 LBS	0.1 KGS

**7731**  
NEW

**5/8"**



STUB IS 5/8 INCH DIAMETER AND IS 1 1/2 INCHES LONG. SEAT IS APPROX. 3/4 INCH SQUARE.

HEIGHT	6 1/4 IN	15.9 CM
WIDTH	1 3/8 IN	3.5 CM
THICK	1 3/8 IN	3.5 CM
WEIGHT	0.2 LBS	0.1 KGS

**8214**  
NEW

**5/8"**



SEAT IS 3/4 INCH SQUARE. STUB SIZE IS 1/2 INCH SQUARE AND IS 1 1/8 INCHES LONG.

HEIGHT	4 7/8 IN	12.4 CM
WIDTH	7/8 IN	2.2 CM
THICK	7/8 IN	2.2 CM
WEIGHT	0.3 LBS	0.2 KGS

**8201**  
NEW

**3/4"**



SEAT IS 1 INCH SQUARE. STUB IS TAPERED AND IS 5/8 INCH SQUARE, 7/8 INCHES LONG.

HEIGHT	4 1/2 IN	11.4 CM
WIDTH	2 1/8 IN	5.4 CM
THICK	1 IN	2.5 CM
WEIGHT	0.2 LBS	0.1 KGS

**7727**  
NEW

**1"**



STUB IS 5/8 INCH LONG BY 7/8 INCH SQUARE. SEAT IS 1 3/8 INCHES SQUARE.

HEIGHT	4 1/4 IN	10.8 CM
WIDTH	1 5/8 IN	4.1 CM
THICK	1 5/8 IN	4.1 CM
WEIGHT	0.2 LBS	0.1 KGS

**8202**  
OLD 2S

**1"**



SEAT IS 1 INCH SQUARE. STUB IS 7/8 INCH SQUARE AND 7/8 INCH LONG.

HEIGHT	4 1/4 IN	10.8 CM
WIDTH	2 1/4 IN	5.7 CM
THICK	1 IN	2.5 CM
WEIGHT	0.2 LBS	0.1 KGS

**8208**  
OLD 8S

**1"**



SEAT IS 1 3/4 INCHES SQUARE. STUB IS 7/8 INCH SQUARE AND 1 1/4 INCHES LONG.

HEIGHT	6 1/2 IN	16.5 CM
WIDTH	2 3/4 IN	7.0 CM
THICK	2 IN	5.1 CM
WEIGHT	0.6 LBS	0.3 KGS

**8268**  
NEW

**1"**

FOR 1/8" WALL



SEAT IS 1 INCH SQUARE. STUB IS TAPERED AND IS 7/8 INCH SQUARE, 7/8 INCHES LONG.

HEIGHT	3 7/8 IN	9.8 CM
WIDTH	1 1/8 IN	2.9 CM
THICK	1 1/8 IN	2.9 CM
WEIGHT	0.1 LBS	0.07 KGS

**8261**  
NEW

**1"**



SEAT IS 1 1/2 INCHES SQUARE. STUB SIZE IS 3/4 INCH SQUARE AND IS 9/16 INCH LONG.

HEIGHT	1 7/8 IN	4.8 CM
WIDTH	1 1/2 IN	3.8 CM
THICK	1 1/2 IN	3.8 CM
WEIGHT	0.1 LBS	0.06 KGS

**9275**  
NEW

**1"**



DRIVE IN STUB IS 3/4 INCH SQUARE AND 2 3/8 INCHES LONG.

SCALE: 1 1/2 INCHES = 1 FOOT

HEIGHT	10 3/8 IN	26.4 CM
WIDTH	2 1/2 IN	6.4 CM
THICK	2 1/2 IN	6.4 CM
WEIGHT	1.2 LBS	0.5 KGS

REVISION DATE: 12/29/94

SCALE: 3 INCHES = 1 FOOT UNLESS NOTED

Section:  
Spears  
Plug In Type

Toll Free (800) 527-1318

(972) 286-2368

Fax: (972) 557-4727



**7718**  
NEW

**3/4"**



STUB IS 1 1/4 INCH LONG BY 5/8 INCH SQUARE. SEAT IS 1 INCH DIAMETER.

HEIGHT	7 1/4 IN	18.4 CM
WIDTH	2 1/4 IN	5.7 CM
THICK	1 1/4 IN	3.2 CM
WEIGHT	0.4 LBS	0.2 KGS

**8209**  
NEW

**1"**



SEAT IS 1 INCH IN DIAMETER. STUB IS 3/4 INCH IN DIAMETER AND 2 3/4 INCHES LONG

HEIGHT	11 3/4 IN	29.8 CM
WIDTH	2 3/4 IN	7.0 CM
THICK	1 3/4 IN	4.4 CM
WEIGHT	0.7 LBS	0.3 KGS

**8211**  
NEW

**1"**



THIS PIECE WAS USED WITH CATALOG NUMBER 9237 (AS SHOWN ON PAGE 47) AT THE VISITORS CENTER, THE WHITE HOUSE, WASHINGTON, D.C.

SEAT IS 7/8 INCH IN DIAMETER. STUB IS 3/4 INCH DIAMETER AND 1 1/2 INCHES LONG.

HEIGHT	10 3/4 IN	27.3 CM
WIDTH	3 IN	7.6 CM
THICK	1 1/2 IN	3.8 CM
WEIGHT	1.1 LBS	0.5 KGS

**7760**  
NEW

**1 1/2"**



STUB IS 1 1/4 INCHES SQUARE BY 3/4 INCHES LONG. SEAT IS 1 5/8 INCHES SQUARE.

SCALE: 3 INCHES = 1 FOOT

HEIGHT	4 7/8 IN	12.4 CM
WIDTH	1 3/4 IN	4.4 CM
THICK	1 3/4 IN	4.4 CM
WEIGHT	0.4 LBS	0.2 KGS

REVISION DATE: 01/30/95

SCALE: 6 INCHES = 1 FOOT UNLESS NOTED



# ALLOY CASTING

Aluminum

Toll Free (800) 527-1318

(972) 286-2368

Fax (972) 557-4727

## SPEARS

## SLIP OVER TYPE

DOUBLE FACE 3/8"  $\square$



INQUIRY

**8238**

HEIGHT 4 5/8"  
WIDTH: 1 1/8"  
THICK: 1 1/8"  
WEIGHT: .2 lbs

DOUBLE FACE 1/2"  $\square$



**8203**

HEIGHT 4 1/4"  
WIDTH: 2 1/4"  
THICK: 7/8"  
WEIGHT: .2 lbs

DOUBLE FACE 1/2"  $\square$



**8204**

HEIGHT 4 1/2"  
WIDTH: 2"  
THICK: 7/8"  
WEIGHT: .2 lbs

DOUBLE FACE 1/2"  $\square$



**8205**

HEIGHT 6 1/4"  
WIDTH: 3 3/4"  
THICK: 1"  
WEIGHT: .4 lbs

DOUBLE FACE 1/2"  $\square$



**8206**

HEIGHT 4 5/8"  
WIDTH: 1 1/8"  
THICK: 1 1/4"  
WEIGHT: 0.2 lbs

DOUBLE FACE 1/2"  $\square$



**8207**

HEIGHT 4 3/8"  
WIDTH: 1 1/4"  
THICK: 1 1/4"  
WEIGHT: 0.1 lbs

DOUBLE FACE 5/8"  $\square$



**8213**

HEIGHT 4 1/4"  
WIDTH: 2"  
THICK: 1"  
WEIGHT: 0.3 lbs

DOUBLE FACE 5/8"  $\square$



**8256**

HEIGHT 4 1/4"  
WIDTH: 1 1/2"  
THICK: 1 1/4"  
WEIGHT: 0.2 lbs

DOUBLE FACE 3/4"  $\square$



SMALL

**634**

HEIGHT 4 1/8"  
WIDTH: 1 1/8"  
THICK: 1 1/8"  
WEIGHT: 0.2 lbs

DOUBLE FACE 3/4"  $\square$



LARGE

**8264**

HEIGHT 6"  
WIDTH: 1 7/8"  
THICK: 1 7/8"  
WEIGHT: 0.4 lbs

DOUBLE FACE 3/4"  $\square$



SMALL

**8223**

HEIGHT 4"  
WIDTH: 2 1/8"  
THICK: 1 1/8"  
WEIGHT: 0.2 lbs

DOUBLE FACE 3/4"  $\square$



LARGE

**8215**

HEIGHT 5 3/8"  
WIDTH: 2 3/4"  
THICK: 1 3/8"  
WEIGHT: 0.3 lbs

Section:  
Spears

Toll Free (800) 527-1318  
(972) 286-2368  
Fax: (972) 557-4727



**9270**  
NEW

**3/4"**



SCALE: 1 1/2 INCHES = 1 FOOT  
MAY BE USED WITH 9269 ON PAGE 59

HEIGHT	8 1/2 IN	21.6 CM
WIDTH	2 1/2 IN	6.4 CM
THICK	2 1/2 IN	6.4 CM
WEIGHT	1.7 LBS	0.5KGS

**8266**  
NEW

**1"**



HEIGHT	7 7/8 IN	20.0 CM
WIDTH	2 1/8 IN	5.4 CM
THICK	2 1/8 IN	5.4 CM
WEIGHT	0.8 LBS	0.4KGS

**8253**  
NEW

**1"**



HEIGHT	6 1/8 IN	15.6 CM
WIDTH	3 1/8 IN	7.9 CM
THICK	1 3/4 IN	4.4 CM
WEIGHT	0.6 LBS	0.3 KGS

**8210**  
OLD 10S



PIECE IS FLAT ON THE BOTTOM

HEIGHT	6 IN	15.2 CM
WIDTH	1 IN	2.5 CM
THICK	1 IN	2.5 CM
WEIGHT	0.3 LBS	0.1 KGS

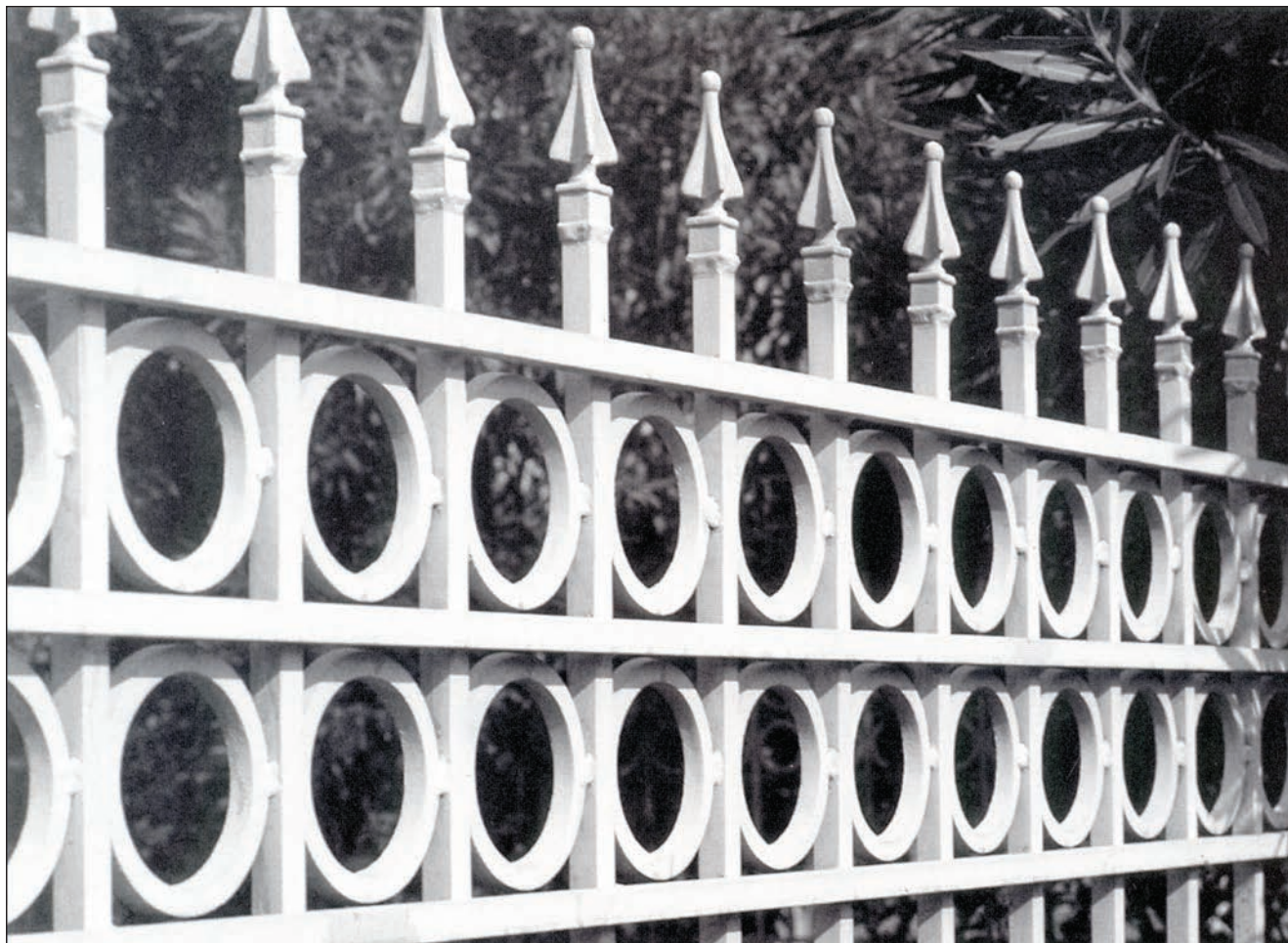

Spear point #8206, circle #7144 and ball finial #8001 in an aluminum fence section.

REVISION DATE: 01/30/95

SCALE: 3 INCHES = 1 FOOT UNLESS NOTED





# Alloy Casting

## ALUMINUM CASTINGS

Toll Free (800) 527-1318

(972) 286-2368

Fax: (972) 557-4727

Section:

Collars

**164**  
NEW

**1/2"**

SIDE VIEW      TOP VIEW

HEIGHT 1 1/2 IN	3.8 CM
WIDTH 1 1/2 IN	3.8 CM
THICK 1 3/4 IN	4.4 CM
WEIGHT 0.2 LBS	0.07 KGS

**165**  
NEW

**5/8"**

SIDE VIEW      TOP VIEW

HEIGHT 1 1/2 IN	3.8 CM
WIDTH 1 1/2 IN	3.8 CM
THICK 1 3/4 IN	4.4 CM
WEIGHT 0.2 LBS	0.07 KGS

**7765**  
NEW

**5/8"**

SIDE VIEW      TOP VIEW

HEIGHT 1 1/8 IN	2.9 CM
WIDTH 1 1/8 IN	2.9 CM
THICK 5/8 IN	1.6 CM
WEIGHT 0.1 LBS	0.05 KGS

**143**  
NEW

**3/4"**

SIDE VIEW      TOP VIEW

HEIGHT 1 1/8 IN	2.9 CM
WIDTH 1 1/8 IN	2.9 CM
THICK 5/8 IN	1.6 CM
WEIGHT 0.1 LBS	0.05 KGS

**140**  
NEW

**1"**

SIDE VIEW      TOP VIEW

HEIGHT 2 1/4 IN	3.8 CM
WIDTH 2 1/4 IN	3.8 CM
THICK 2 1/4 IN	4.4 CM
WEIGHT 0.5 LBS	0.07 KGS

**9332**  
NEW

**2"**

THIS PIECE MATCHES "BALL CAP"  
NUMBER 9333 ON PAGE 86.

SIDE VIEW      TOP VIEW

HEIGHT 3 IN	7.6 CM
WIDTH 3 IN	7.6 CM
THICK 1 3/8 IN	1.9 CM
WEIGHT 0.4 LBS	0.2 KGS



Spear point #8206, collar #0143, and diamond pattern #530 in a short wall fence top.

**141**  
NEW

**1/2"**

SIDE VIEW      TOP VIEW

HEIGHT 1 3/8 IN	3.5 CM
WIDTH 1 3/8 IN	3.3 CM
THICK 7/8 IN	2.2 CM
WEIGHT 0.1 LBS	0.03 KGS

**142**  
NEW

**1/2"**

SIDE VIEW      TOP VIEW

HEIGHT 1 3/8 IN	3.5 CM
WIDTH 1 3/8 IN	3.5 CM
THICK 1 5/8 IN	4.1 CM
WEIGHT 0.1 LBS	0.03 KGS

**30**

**3"**

SCHEMATIC TOP VIEW

TWO PIECES ARE REQUIRED PER ASSEMBLY WHICH FITS AROUND A 3 INCH PIPE. PIECE HAS SCREW LUGS OR PIECES CAN BE WELDED TOGETHER.

HEIGHT 5 IN	12.7 CM
WIDTH 5 3/8 IN	13.6 CM
THICK 5 3/8 IN	13.6 CM
WEIGHT 0.7 LBS	0.3 KGS

REVISION DATE: 01/23/95

SCALE: NONE

# BALL CAPS

Toll Free (800) 527-1318  
 (972) 286-2368  
 Fax (972) 557-4727

## ALLOY CASTING

Aluminum



DOUBLE FACE 3/4"



BALL DIA IS 7/8" HOLE 7/8 SQ.

**3407**

HEIGHT	1 3/4"
WIDTH:	1 1/8"
THICK:	1 1/8"
WEIGHT:	0.2 lbs

DOUBLE FACE 1"



BALL DIA IS 1 1/8"  
 PHOTO NOT TO SCALE

**3410**

HEIGHT	2 3/8"
WIDTH:	1 1/2"
THICK:	1 1/2"
WEIGHT:	0.2 lbs

DOUBLE FACE 1 1/2"



BALL DIA IS 1 5/8"

**3415**

HEIGHT	2 5/8"
WIDTH:	2"
THICK:	2"
WEIGHT:	.7 lbs

DOUBLE FACE 2"



BALL DIA IS 1 3/4"

**3420**

HEIGHT	3 3/4"
WIDTH:	2 3/8"
THICK:	2 3/8"
WEIGHT:	0.6 lbs

DOUBLE FACE 2"



BALL DIA IS 1 1/2" AND PIECE  
 MATCHES COLLAR #9332  
 SHOWN ON PAGE 85

**9333**

HEIGHT	5 1/4"
WIDTH:	3"
THICK:	3"
WEIGHT:	1.5 lbs

DOUBLE FACE 2 1/2"



BALL DIA IS 2"

**3425**

HEIGHT	4"
WIDTH:	3"
THICK:	3"
WEIGHT:	0.8 lbs

DOUBLE FACE 3"



BALL DIA IS 2"

**3430**

HEIGHT	4 3/4"
WIDTH:	3 5/8"
THICK:	3 5/8"
WEIGHT:	1.5 lbs

DOUBLE FACE 4"



BALL DIA IS 2 1/2"

**3440**

HEIGHT	5 1/8"
WIDTH:	4 3/8"
THICK:	4 3/8"
WEIGHT:	2.2 lbs

**NEW**

DOUBLE FACE 4"



BALL DIA IS 4"

**3441**

HEIGHT	6"
WIDTH:	4 5/8"
THICK:	4 5/8"
WEIGHT:	2.3 lbs

**NEW**

DOUBLE FACE 6"



BALL DIA IS 5"

**3460**

HEIGHT	8 1/2"
WIDTH:	6 1/2"
THICK:	6 1/2"
WEIGHT:	4.0 lbs

**NEW**

DOUBLE FACE



**3418**

HEIGHT	18"
WIDTH:	18"
THICK:	1/2" wall
WEIGHT:	30.00 lbs

**NEW**

DOUBLE FACE 4"

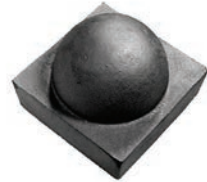

SEMI SPHERE TOP 4" DIA  
 AND 2 1/4" HIGH

**3204**

HEIGHT	3 3/4"
WIDTH:	5 1/8"
THICK:	5 1/8"
WEIGHT:	1.9 lbs



# ALLOY CASTING

Aluminum

Toll Free (800) 527-1318

(972) 286-2368

Fax (972) 557-4727

## BALL FINIALS

DOUBLE FACE ∅



PIECE HAS A FLAT BASE 1 1/8" DIA  
BALL IS 1 1/4" DIA

**8001**

HEIGHT	1 7/8"
WIDTH:	1 1/4"
THICK:	1 1/4"
WEIGHT:	0.2 lbs

DOUBLE FACE 3/4" ■



BALL IS 13/16" DIA  
TUBE SEAT IS 1" SQ.  
STUB IS 9/16 SQ AND 3/4" LONG

**8003**

HEIGHT	1 7/8"
WIDTH:	3/4"
THICK:	3/4"
WEIGHT:	.06 lbs

DOUBLE FACE 1" ■



BALL IS 1" DIA.  
TUBE SEAT IS 15/16" SQ.  
STUB IS 7/8" SQ. AND 5/8" LONG

**7717**

HEIGHT	2 3/8"
WIDTH:	1 1/4"
THICK:	1 1/4"
WEIGHT:	0.2 lbs

**NEW**

DOUBLE FACE 1 1/2" ■



BALL IS 1 5/8" DIA  
SET IS 1 5/8" IN SQ.  
STUB IS 1 1/8" SQ BY 1" LONG

**7792**

HEIGHT	3 1/2"
WIDTH:	1 5/8"
THICK:	1 5/8"
WEIGHT:	0.5 lbs

DOUBLE FACE 1 1/2" ■



BALL IS 1 1/2" DIA  
TUBE SEAT IS 1 5/8" SQ.  
STUB IS 1 1/4 SQ AND 1/2" LONG

**7759**

HEIGHT	2 5/8"
WIDTH:	1 5/8"
THICK:	1 5/8"
WEIGHT:	0.4 lbs

DOUBLE FACE 1 1/2" ■



BALL IS 1" DIA  
TUBE SEAT IS 1 1/2" SQ.  
STUB IS 1 3/8 SQ AND 1/2" LONG

**1409**

HEIGHT	2 3/4"
WIDTH:	1 1/2"
THICK:	1 1/2"
WEIGHT:	0.2 lbs

DOUBLE FACE 2" ■



BALL IS 2" DIA  
TUBE SEAT IS 2 1/4" SQ.  
STUB IS 1 7/8 SQ AND 1" LONG

**8005**

HEIGHT	4"
WIDTH:	2 1/4"
THICK:	2 1/4"
WEIGHT:	1.0 lbs

**NEW**

DOUBLE FACE



BALL IS 1 3/4" DIA  
TUBE SEAT IS 1 1/8" SQ.  
STUB IS 5/8 SQ AND 3/4" LONG

**8057**

HEIGHT	3 1/4"
WIDTH:	1 3/4"
THICK:	1 3/4"
WEIGHT:	0.4 lbs

**NEW**

∅



BALL IS 1 17/8" DIA  
BASE IS 1 1/2" DIA

**8054**

HEIGHT	2 7/8"
WIDTH:	1 7/8"
THICK:	1 7/8"
WEIGHT:	0.4 lbs

**NEW**

∅



BALL IS 2 1/2" IN DIA.  
BASE IS 1 1/2" IN DIA.

**8055**

HEIGHT	2 3/4"
WIDTH:	2 1/8"
THICK:	2 1/8"
WEIGHT:	0.6 lbs

**NEW**

∅



BALL IS 2 1/4" IN DIA.

**8040**

HEIGHT:	2 3/4"
WIDTH:	2 1/4"
THICK:	2 1/4"
WEIGHT:	0.6 lbs

**NEW**



BALL IS 1 3/8" IN DIA  
STUB 1/2" DIA. X 3/8" LONG

**9072**

HEIGHT	3 3/4"
WIDTH:	2 1/4"
THICK:	2 1/4"
WEIGHT:	0.4 lbs

# BALL FINIALS

Toll Free (800) 527-1318  
 (972) 286-2368  
 Fax (972) 557-4727

## ALLOY CASTING

Aluminum



**NEW**

DOUBLE FACE  $\emptyset$



PIECE HAS A BASE 2 7/8 " DIA  
 BALL IS 3" DIA

**8033**

HEIGHT 3 3/4"  
 WIDTH: 3"  
 THICK: 3"  
 WEIGHT: 1.8

**NEW**

DOUBLE FACE  $\emptyset$



PIECE HAS A BASE 1 1/2 " DIA  
 BALL IS 2 1/4" DIA

**8075**

HEIGHT 2 3/4"  
 WIDTH: 2 1/4"  
 THICK: 2 1/4"  
 WEIGHT: 0.6

HEIGHT  
 WIDTH:  
 THICK:  
 WEIGHT:

HEIGHT  
 WIDTH:  
 THICK:  
 WEIGHT:

HEIGHT  
 WIDTH:  
 THICK:  
 WEIGHT:

HEIGHT  
 WIDTH:  
 THICK:  
 WEIGHT:

HEIGHT  
 WIDTH:  
 THICK:  
 WEIGHT:

HEIGHT  
 WIDTH:  
 THICK:  
 WEIGHT:

HEIGHT  
 WIDTH:  
 THICK:  
 WEIGHT:

HEIGHT  
 WIDTH:  
 THICK:  
 WEIGHT:

HEIGHT  
 WIDTH:  
 THICK:  
 WEIGHT:

HEIGHT  
 WIDTH:  
 THICK:  
 WEIGHT:







ALUMINUM CASTINGS

**8304**  
NEW

**DF**



HEIGHT 8 5/8 IN 21.9 CM  
WIDTH 5 1/2 IN 14.0 CM  
THICK 1 IN 2.5 CM  
WEIGHT 0.4 LBS 0.2 KGS

**8305**  
NEW

**DF**



HEIGHT 8 3/8 IN 21.3 CM  
WIDTH 5 1/4 IN 13.3 CM  
THICK 1 1/8 IN 2.9 CM  
WEIGHT 0.4 LBS 0.2 KGS

**8306**  
NEW

**DF**



HEIGHT 8 IN 21.9 CM  
WIDTH 3 3/8 IN 8.6 CM  
THICK 1 1/8 IN 2.9 CM  
WEIGHT 0.4 LBS 0.2 KGS

**8307**  
NEW

**DF**



HEIGHT 9 IN 22.9 CM  
WIDTH 4 IN 10.2 CM  
THICK 1 1/8 IN 2.9 CM  
WEIGHT 0.4 LBS 0.2 KGS

**8309**  
NEW

**DF**



HEIGHT 8 3/4 IN 22.2 CM  
WIDTH 4 1/8 IN 10.5 CM  
THICK 1 IN 2.5 CM  
WEIGHT 0.3 LBS 0.2 KGS

**8310**  
NEW

**DF**



HEIGHT 8 1/2 IN 21.6 CM  
WIDTH 5 IN 12.7 CM  
THICK 1 1/4 IN 3.2 CM  
WEIGHT 0.4 LBS 0.2 KGS

**8311**  
NEW

**DF**



HEIGHT 8 3/8 IN 21.3 CM  
WIDTH 3 5/8 IN 9.2 CM  
THICK 1 1/8 IN 2.9 CM  
WEIGHT 0.2 LBS 0.1 KGS

**8314**  
NEW

**DF**



HEIGHT 8 7/8 IN 22.5 CM  
WIDTH 5 1/2 IN 14.0 CM  
THICK 1 1/8 IN 2.9 CM  
WEIGHT 0.4 LBS 0.2 KGS

**8316**  
NEW

**DF**



HEIGHT 8 3/4 IN 22.2 CM  
WIDTH 3 1/2 IN 8.9 CM  
THICK 1 1/8 IN 2.9 CM  
WEIGHT 0.3 LBS 0.1 KGS

**8317**  
NEW

**DF**



HEIGHT 8 5/8 IN 21.9 CM  
WIDTH 5 1/2 IN 14.0 CM  
THICK 1 IN 2.5 CM  
WEIGHT 0.4 LBS 0.2 KGS

**8319**  
NEW

**DF**



HEIGHT 6 1/2 IN 16.5 CM  
WIDTH 6 1/2 IN 16.5 CM  
THICK 1/2 IN 1.3 CM  
WEIGHT 0.2 LBS 0.1 KGS



# Alloy Casting

ALUMINUM CASTINGS

Toll Free (800) 527-1318

(972) 286-2368

Fax: (972) 557-4727

Section:

Roof Crestings  
And Marquees

**9243** **FB**  
NEW

HEIGHT 32 3/4 IN 83.3 CM  
WIDTH 12 5/8 IN 32.1 CM  
THICK 3/4 IN 1.9 CM  
WEIGHT 9.6 LBS 4.4 KGS

**8562** **FB**  
NEW

HEIGHT 18 IN 45.7 CM  
WIDTH 18 1/8 IN 46.0 CM  
THICK 1/4 IN 1.0 CM  
WEIGHT 2.2 LBS 1.0 KGS

**8561** **FB**  
NEW

HEIGHT 20 1/2 IN 52.1 CM  
WIDTH 16 3/4 IN 42.5 CM  
THICK 1/4 IN 0.6 CM  
WEIGHT 1.1 LBS 0.5 KGS

**835** **FB**  
NEW

HEIGHT 15 1/8 IN 38.4 CM  
WIDTH 17 3/4 IN 45.1 CM  
THICK 3/8 IN 1.0 CM  
WEIGHT 2.1 LBS 1.0 KGS

**454** **FB**  
NEW

HEIGHT 19 5/8 IN 50.0 CM  
WIDTH 16 1/4 IN 41.3 CM  
THICK 1 7/8 IN 4.8 CM  
WEIGHT 1.9 LBS ET. 0.9 KGS

**452** **FB**  
NEW

HEIGHT 18 1/2 IN 47.0 CM  
WIDTH 5 5/8 IN 14.3 CM  
THICK 2 IN 5.1 CM  
WEIGHT 1.9 LBS EST 0.9 KGS

**9247** **FB**  
NEW

NOTE: THIS IS A "MARQUEE" CASTING

HEIGHT 15 7/8 IN 40.3 CM  
WIDTH 19 IN 48.3 CM  
THICK 3/4 IN 1.9 CM  
WEIGHT 8.8 LBS 4.0 KGS

**9134** **FB**  
NEW

NOTE: THIS IS A "MARQUEE" CASTING

HEIGHT 18 IN 47.0 CM  
WIDTH 13 IN 32.1 CM  
THICK 1 1/4 IN 3.2 CM  
WEIGHT 8.0 LBS 3.7 KGS

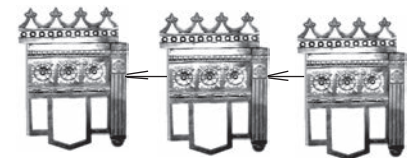

NOTE: ALL "MARQUEE" CASTINGS "NEST" AS SHOWN.

REVISION DATE: 12/30/94

SCALE: 1 INCH = 1 FOOT UNLESS NOTED

Section:

**Shelf Brackets And  
Decorative Items**

Toll Free (800) 527-1318

(972) 286-2368

Fax: (972) 557-4727



**ALUMINUM CASTINGS**

**71 DF**



HEIGHT 10 IN	25.4 CM
WIDTH 6 3/4 IN	17.1 CM
THICK 1 3/8 IN	3.5 CM
WEIGHT 0.5 LBS	0.2 KGS

**72 DF**

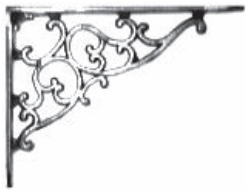

HEIGHT 5 3/4 IN	14.6 CM
WIDTH 7 1/2 IN	19.0 CM
THICK 7/8 IN	2.2 CM
WEIGHT 0.3 LBS	0.2 KGS

**73 DF**



HEIGHT 6 1/4 IN	15.9 CM
WIDTH 5 1/2 IN	14.0 CM
THICK 11/16 IN	1.7 CM
WEIGHT 0.3 LBS	0.2 KGS

**590 DF**



HEIGHT 9 IN	22.9 CM
WIDTH 9 IN	22.9 CM
THICK 3/4 IN	1.9 CM
WEIGHT 0.5 LBS	0.2 KGS

**9154 DF**  
NEW



RAMS HEAD

SCALE: 1 INCH = 4 INCHES



NOTE: TOP VIEW, PIECE FITS AROUND A CORNER.

HEIGHT 5 IN	12.7 CM
WIDTH 4 3/8 IN	11.1 CM
THICK 2 3/4 IN	7.0 CM
WEIGHT 1.1 LBS	0.5 KGS

**9184 FB**  
NEW



GRIFFIN

HEIGHT 4 3/4 IN	12.1 CM
WIDTH 11 1/2 IN	29.2 CM
THICK 1/4 IN	0.6 CM
WEIGHT 0.6 LBS	0.3 KGS

**7768 DF**  
NEW

WINGED LADY



FRONT VIEW      PROFILE SIDE VIEW

HEIGHT 11 IN	27.9 CM
WIDTH 5 1/2 IN	14.0 CM
THICK 3 1/8 IN	7.9 CM
WEIGHT 1.6 LBS	0.7 KGS

**9113 DF**  
NEW

SET



SCALE: 1 INCH = 4 INCHES

HEIGHT 4 3/8 IN	6.0 CM
WIDTH 2 IN	5.1 CM
THICK 1 1/8 IN	2.9 CM
WEIGHT 0.3 LBS	0.1 KGS

**9202 FB**  
NEW



PIECE HAS 4 MOUNTING BOSSES ON THE BACK SIDE.

HEIGHT 13 1/8 IN	33.3 CM
WIDTH 23 IN	58.4 CM
THICK 1 1/2 IN	3.8 CM
WEIGHT 4.3 LBS	2.0 KGS

**9203 FB**  
NEW



PIECE HAS 4 MOUNTING BOSSES ON THE BACK SIDE.

HEIGHT 9 3/4 IN	24.8 CM
WIDTH 30 IN	76.2 CM
THICK 1 1/2 IN	3.8 CM
WEIGHT 5.1 LBS	2.3 KGS

**191 DF**  
NEW



PICTURE FRAME

NOTE: SCALE 1 INCH = 1 FOOT

HEIGHT 14 3/4 IN	37.5 CM
WIDTH 10 IN	25.4 CM
THICK 5/8 IN	1.6 CM
WEIGHT 0.6 LBS	0.3 KGS

REVISION DATE:11/12/94

SCALE:1/2 INCH = 1 FOOT UNLESS NOTED





# Alloy Casting

## ALUMINUM CASTINGS

Toll Free (800) 527-1318

(972) 286-2368

Fax: (972) 557-4727

Section:

Furniture Pieces

### 68 TABLE LEG

NEW



NOTE: THIS PIECE IS NOT TO SCALE

FRONT VIEW

SIDE VIEW

HEIGHT	26 1/4 IN	66.7 CM
WIDTH	7 IN	17.8 CM
THICK	5 1/2 IN	14.0 CM
WEIGHT	2.3 LBS	1.0 KGS

### 70 TABLE LEG

NEW

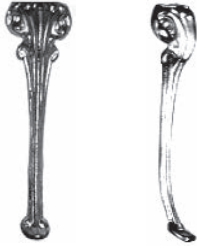

FRONT VIEW

SIDE VIEW

HEIGHT	15 IN	38.1 CM
WIDTH	5 IN	12.7 CM
THICK	2 7/8 IN	7.3 CM
WEIGHT	1.2 LBS	0.6 KGS

### 9255 TABLE LEG

NEW



FRONT VIEW

SIDE VIEW

HEIGHT	17 5/8 IN	44.8 CM
WIDTH	3 7/8 IN	9.8 CM
THICK	4 IN	10.2 CM
WEIGHT	8.1 LBS	3.7 KGS

### 74 TABLE LEG

NEW



HEIGHT	16 IN	40.6 CM
WIDTH	5 1/4 IN	13.3 CM
THICK	1 1/4 IN	3.2 CM
WEIGHT	1.0 LBS	0.5 KGS

### 69 TABLE TOP

NEW



HEIGHT	13 IN	33.0 CM
WIDTH	13 IN	33.0 CM
THICK	3/8 IN	1.0 CM
WEIGHT	1.5 LBS	0.7 KGS

### 2070 TABLE TOP

NEW



HEIGHT	12 IN	30.5 CM
WIDTH	12 IN	30.5 CM
THICK	7/8 IN	2.2 CM
WEIGHT	1.9 LBS	0.8 KGS

### 75 TABLE TOP

NEW



HEIGHT	12 3/4 IN	32.3 CM
WIDTH	12 3/4 IN	32.3 CM
THICK	5/16 IN	0.8 CM
WEIGHT	2.1 LBS	0.9 KGS

Cocktail table with polished seashell #3725 and table legs 9255.

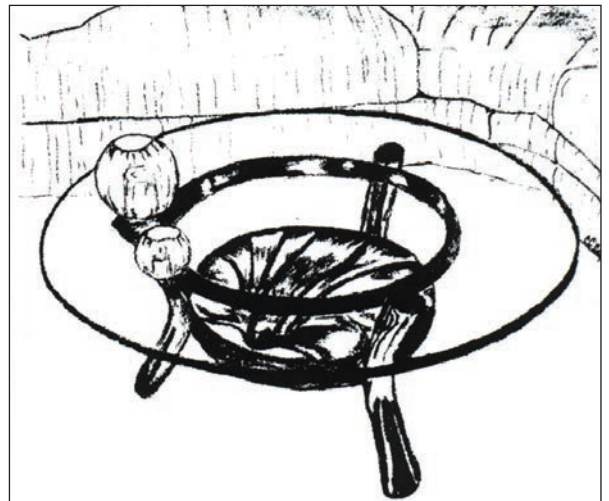

REVISION DATE: 03/28/95

SCALE: 1 INCH = 1 FOOT UNLESS NOTED

Section:

Assemblies:  
Flower Pot

Toll Free (800) 527-1318

(972) 286-2368

Fax: (972) 557-4727



ALUMINUM CASTINGS

**110**

**DF**

NEW



TOP VIEW



SIDE VIEW

SCALE: 1 INCH = 4 INCHES

HEIGHT	2 3/8 IN	6.0 CM
WIDTH	3 1/4 IN	8.3 CM
THICK	2 3/4 IN	7.0 CM
WEIGHT	0.3 LBS	0.1 KGS

**111**

**DF**

NEW



SCALE: 1 INCH = 4 INCHES

HEIGHT	5 1/2 IN	14.0 CM
WIDTH	6 1/2 IN	16.5 CM
THICK	1/2 IN	1.3 CM
WEIGHT	0.3 LBS	0.1 KGS

**112**

**DF**

NEW



TOP VIEW



SIDE VIEW

SCALE: 1 INCH = 4 INCHES

HEIGHT	3 IN	7.6 CM
WIDTH	4 1/2 IN	11.4 CM
THICK	3 5/8 IN	9.2 CM
WEIGHT	0.4 LBS	0.3 KGS

**113**

**DF**

NEW



HEIGHT	6 3/4 IN	17.1 CM
WIDTH	7 1/2 IN	19.0 CM
THICK	5/8 IN	1.6 CM
WEIGHT	0.3 LBS	0.2 KGS

**114**

**DF**

NEW



TOP VIEW



SIDE VIEW

SCALE: 1 INCH = 4 INCHES

HEIGHT	4 1/2 IN	11.4 CM
WIDTH	5 1/8 IN	13.0 CM
THICK	4 IN	10.1 CM
WEIGHT	1.0 LBS	0.4 KGS

**115**

**DF**

NEW



HEIGHT	10 1/2 IN	26.7 CM
WIDTH	9 1/8 IN	23.2 CM
THICK	5/8 IN	1.6 CM
WEIGHT	1.0 LBS	0.4 KGS

**90**

**FB**

NEW

TOP HOLE IS FOR A 1/4 INCH SCREW.



"FLOWER POT BACK" CAN BE USED WITH POTS 110, 112, OR 114.

HEIGHT	13 IN	33.0 CM
WIDTH	6 1/4 IN	15.9 CM
THICK	3/8 IN	1.0 CM
WEIGHT	1.2 LBS	0.5 KGS

**83**

**DF**

NEW

CM



TOP VIEW



SIDE VIEW

POT

HEIGHT	11 1/8 IN	28.3 CM
WIDTH	6 3/4 IN	17.1 CM
THICK	3 1/4 IN	8.3 CM
WEIGHT	1.1 LBS	0.5 KGS

**116 DF**

NEW



TOP VIEW



SIDE VIEW

SCALE: 1 INCH = 4 INCHES

HEIGHT	4 5/8 IN	28.3 CM
WIDTH	6 1/4 IN	15.9 CM
THICK	5 1/2 IN	14.0 CM
WEIGHT	1.2 LBS	0.5 KGS

REVISION DATE: 02/02/95

SCALE: 1 INCH = 1 FOOT UNLESS NOTED



# Alloy Casting

## ALUMINUM CASTINGS

Toll Free (800) 527-1318

(972) 286-2368

Fax: (972) 557-4727

Section:

## Assemblies and Sundials

**7701**      **DF**  
NEW

7701, 7712 AND 7735 WILL MAKE A BELL ASSEMBLY IF DESIRED.



**SET**

**7712**  

CLAPPER FOR BELL

SCALE: 3 INCHES = 1 FOOT

HEIGHT 4 1/2 IN	11.4 CM
WIDTH 5 7/8 IN	14.9 CM
THICK 5 7/8 IN	14.9 CM
WEIGHT 1.2 LBS	0.6 KGS

**7735**      **DF**  
NEW



THIS PIECE MAY BE USED AS PART OF A BELL ASSEMBLY, OR A WALL HANGING BRACKET OR ONE PART OF A GUN RACK.

HEIGHT 10 IN	25.4 CM
WIDTH 7 1/4 IN	18.4 CM
THICK 5 1/2 IN	14.0 CM
WEIGHT 1.0 LBS	0.4 KGS

**7730**      **DF**  
NEW



- INSCRIPTION-  
"GROW OLD ALONG WITH ME  
THE BEST IS YET TO BE"

FOR THIS SUN DIAL FACE.  
USE 7742 AS A POINTER.

HEIGHT 10 IN	25.4 CM
WIDTH 10 IN	25.4 CM
THICK 3/8IN	1.0 CM
WEIGHT 1.2 LBS	0.6 KGS

**7794**      **DF**  
NEW



USE SUN DIAL FACE 7730 WITH THIS POINTER.

SCALE: 3 INCHES = 1 FOOT

HEIGHT 4 1/4 IN	5.1 CM
WIDTH 4 1/4 IN	5.1 CM
THICK 1/2 IN	1.3 CM
WEIGHT 0.05 LBS	0.02 KGS

**7750**      **DF**  
NEW



**SET**

SUN DIAL FACE. USE 7707 AS A POINTER.

HEIGHT 7 1/2 IN	19.0 CM
WIDTH 7 1/2 IN	19.0 CM
THICK 1/4 IN	0.6 CM
WEIGHT 0.6 LBS	0.3 KGS

**7707**      **DF**  
NEW



USE SUN DIAL FACE 7750 WITH THIS POINTER.

SCALE: 3 INCHES = 1 FOOT

HEIGHT 3 1/4 IN	8.3 CM
WIDTH 4 1/4 IN	10.8 CM
THICK 1/2 IN	1.3 CM
WEIGHT 0.1LBS	0.04 KGS

**7755**      **FB**  
NEW

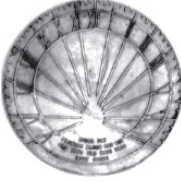

- INSCRIPTION-  
"HOURS FLY  
FLOWERS BLOOM AND DIE  
OLD DAYS OLD WAYS PASS  
LOVE STAYS"

HEIGHT 11 IN	27.9 CM
WIDTH 11 IN	27.9 CM
THICK 3/8IN	0.9 CM
WEIGHT 1.5 LBS	0.7 KGS

**7707**      **DF**  
NEW



USE SUN DIAL FACE 7755 WITH THIS POINTER.

SCALE: 3 INCHES = 1 FOOT

HEIGHT 3 1/4 IN	8.3 CM
WIDTH 4 1/4 IN	10.8 CM
THICK 1/2 IN	1.3 CM
WEIGHT 0.1 LBS	0.04 KGS

Section:  
Assemblies

Toll Free (800) 527-1318  
(972) 286-2368  
Fax: (972) 557-4727



**3744**  
NEW

**DF**

**SET**

HEIGHT 4 3/8 IN  
WIDTH 13 3/8 IN  
THICK 1 1/4 IN  
WEIGHT 0.5 LBS

WIND VANE DIRECTIONAL ARM

11.1 CM  
34.0 CM  
3.2 CM  
0.2 KGS

**3745**  
NEW

**DF**

HEIGHT 4 3/8 IN  
WIDTH 13 3/8 IN  
THICK 1 1/4 IN  
WEIGHT 0.5 LBS

WIND VANE DIRECTIONAL ARM

11.1 CM  
34.0 CM  
3.2 CM  
0.2 KGS

**3746**  
NEW

**DF**

**SET**

HEIGHT 2 1/2 IN  
WIDTH 23 1/2 IN  
THICK 1 1/4 IN  
WEIGHT 0.9 LBS

WIND VANE POST

5.4 CM  
60.3 CM  
3.2 CM  
0.4 KGS

**3742**  
NEW

**DF**

HEIGHT 6 5/8 IN  
WIDTH 28 1/2 IN  
THICK 1 1/4 IN  
WEIGHT 1.7 LBS

WIND VANE PIVOT ARM

18.2 CM  
72.4 CM  
3.2 CM  
0.8 KGS

**3743**  
NEW

**DF**

HEIGHT 8 3/4 IN  
WIDTH 17 3/4 IN  
THICK 7/8 IN  
WEIGHT 1.3 LBS

WIND VANE PIVOT ARM

22.2 CM  
45.1 CM  
2.2 CM  
0.6 KGS

**8618**  
NEW

**DF**

HEIGHT 10 IN  
WIDTH 17 1/2 IN  
THICK 3/4 IN  
WEIGHT 1.0 LBS

WIND VANE PIVOT ARM

25.4 CM  
44.4 CM  
1.9 CM  
0.5 KGS

**81**  
NEW

**DF**

HEIGHT 9 5/8 IN  
WIDTH 8 1/4 IN  
THICK 2 3/8 IN  
WEIGHT 1.5 LBS

FOOT SCRAPER

24.3 CM  
21.0 CM  
6.0 CM  
0.7 KGS

**3736**  
NEW

**DF**

CANDLE STICK HOLDER, TO BE WALL MOUNTED.

HEIGHT 3 3/4 IN  
WIDTH 7 1/2 IN  
THICK 3 IN  
WEIGHT 0.3 LBS

INQUIRY

9.5 CM  
19.0 CM  
7.6 CM  
0.1 KGS



## BENCH ENDS

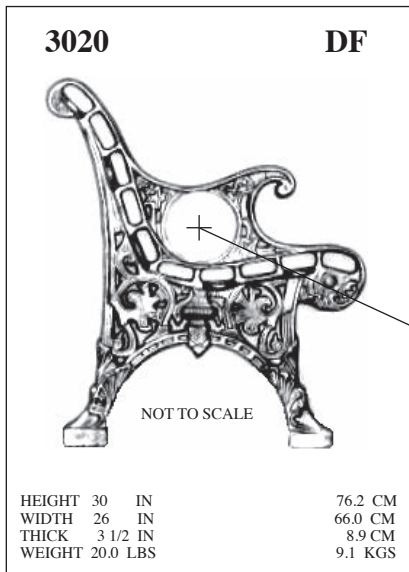

The flexibility of the green sand casting system used at ALLOY CASTING allows freedom in designing special items for your customers. On this page are examples of how you may use this freedom to specialize Bench Ends unique to you or your customer. Shown are several interchangeable symbols that represent some of the various designs that can be used. Each insert is 5 5/8 inches in diameter. Additionally your designs can be inlaid into floor grates, tree grates, ballister columns, trash containers, security windows and many other systems as your needs might dictate. Let us help develop your ideas. See page 43 for other standard circles that fit into the arm of this bench end piece.



**3025**

## **BENCH ASSEMBLY RUST FREE**

(INQUIRY)

Benches include two ends with your choice of circles (see note above) welded into the arms (which are powder coated) 10 wooden slats that are nominally 46 inches long, 20 stainless steel carriage bolts powder coated to match bench arms. Wood for the bench ends are pre drilled for easy assembly. Prices may vary because of the volatility of the price of wood. Instructions for assembly are provided. Tools required for assembly are a small hammer and a 9/16 inch wrench.

Section:  
Lockboxes

Toll Free (800) 527-1318  
(972) 286-2368  
Fax: (972) 557-4727



**ALUMINUM LOCKBOXES**  
**ALLOY 5052 - 1/8 INCH THICK**

LOCKSET HOLES ARE 2 1/8 INCHES IN DIAMETER FOR 2 3/8 INCHES BACK SET  
BOXES COME WITH STAINLESS STEEL SCREWS FOR STRIKE PLATE

**WELDABLE ONE HOLE - WITH GUARD**

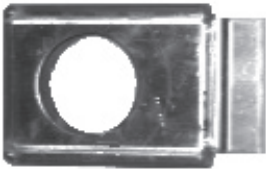
	CATALOG NO.	<b>1182</b>		<b>1183</b>		<b>1184</b>		<b>1188</b>	
	THICKNESS	<b>1 1/4</b> IN	3.2 CM	<b>1 3/8</b> IN	3.5 CM	<b>1 1/2</b> IN	3.8 CM	<b>2</b> IN	5.1 CM
	HEIGHT	3 3/8 IN	17.2 CM	3 3/8 IN	17.2 CM	3 3/8 IN	17.2 CM	3 3/8 IN	17.2 CM
	WIDTH	4 1/4 IN	10.8 CM	4 1/4 IN	10.8 CM	4 1/4 IN	10.8 CM	4 1/4 IN	10.8 CM
	WEIGHT	0.4 LB	0.19 KG	0.4 LB	0.20 KG	0.4 LB	0.21 KG	0.4 LB	0.22 KG

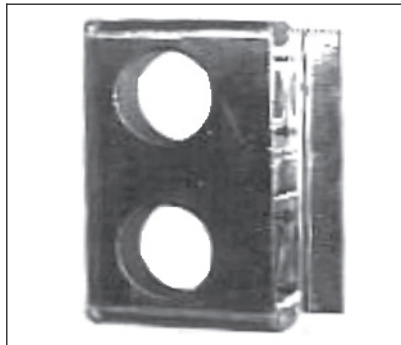

**WELDABLE TWO HOLE - WITH GUARD**

CATALOG NO.	<b>1283</b>		<b>1284</b>		<b>1286</b>		<b>1288</b>	
THICKNESS	<b>1 3/8</b> IN	3.5 CM	<b>1 1/2</b> IN	3.8 CM	<b>1 3/4</b> IN	4.4 CM	<b>2</b> IN	5.1 CM
HEIGHT	6 7/8 IN	18.3 CM	6 7/8 IN	18.3 CM	6 7/8 IN	18.3 CM	6 7/8 IN	18.3 CM
WIDTH	4 1/4 IN	10.8 CM	4 1/4 IN	10.8 CM	4 1/4 IN	10.8 CM	4 1/4 IN	10.8 CM
WEIGHT	0.9 LB	0.39 KG	0.9 LB	0.39 KG	0.9 LB	0.39 CM	0.9 LB	0.39 KG

## ALUMINUM LOCKBOXES ALLOY 5052 - 1/8 INCH THICK

BOXES COME WITH STAINLESS STEEL SCREWS FOR STRIKE PLATE

### BOLT ON - ONE HOLE - WITH GUARD

CAN BE USED WITH PREPAINTED TUBING

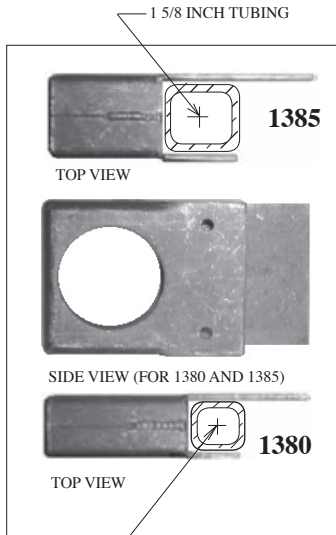

NOTE: ON THE 1385 (1 5/8 INCH TUBING) AND THE 1388 (2 INCH TUBING), LOCK SETS WITH EXTRA LONG TANGS MUST BE USED.

CATALOG NO.	1380		1385		1388	
TUBING	1"		1 5/8"		2"	
THICKNESS	1 1/4 IN	5.7 CM	1 7/8 IN	4.8 CM	2 IN	3.2 CM
HEIGHT	3 1/4 IN	17.2 CM	3 1/4 IN	8.3 CM	3 1/4 IN	8.3 CM
WIDTH	5 3/16 IN	11.1 CM	5 3/4 IN	14.6 CM	5 IN	13.5 CM
WEIGHT	0.3 LB	0.2 KG	0.4 LB	0.2 KG	0.4 LB	0.2 KG
HOLES	4 @ 1/4 IN DIAM.		4 @ 1/4 IN DIAM.		4 @ 13/64 IN SQUARE	
BACKSET	2 3/8		2 3/4		2 3/8	

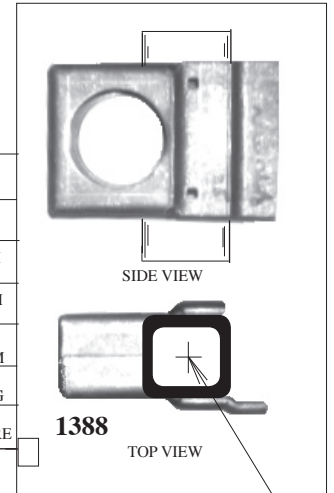

NOTE: THE 1388 LOCK BOX FITS OVER STANDARD 2 INCH ALUMINUM TUBING. HOLES ON THE SIDE OF THE LOCKBOX ARE 13/64 INCH SQUARE FOR USE WITH 3/16 INCH CARRIAGE BOLTS (4 PLACES). 2 INCH TUBING MUST BE CUT OUT, 7/8 INCH BY 3 1/4 INCHES, TO SLIP IN (AND OVER) THE LOCK BOX.

### BOLT ON - TWO HOLE - WITH GUARD

CAN BE USED WITH PREPAINTED TUBING

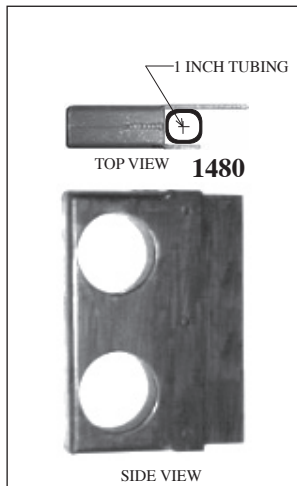

NOTE: ON THE 1485 (1 1/2 INCH TUBING), LOCK SETS WITH EXTRA LONG TANGS MUST BE USED.

CATALOG NO.	1480		1485	
TUBING	1"		1 5/8"	
THICKNESS	1 1/4 IN	3.2 CM	1 7/8 IN	4.8 CM
HEIGHT	6 7/8 IN	17.5 CM	6 7/8 IN	17.5 CM
WIDTH	5 1/4 IN	13.3 CM	5 3/4 IN	14.6 CM
WEIGHT	0.7 LB	0.3 KG	0.8 LB	0.4 KG
HOLES	6 @ 1/4 IN DIAM.		6 2 1/4 IN DIAM	
BACKSET	2 3/8		2 3/4	

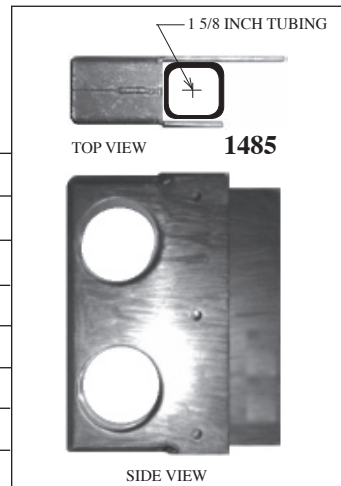

ALL ALUMINUM HARDWARE  
CAST ALUMINUM PLATES

**1066** **FB**  
NEW



HEIGHT	6 IN	15.2 CM
WIDTH	6 IN	15.2 CM
THICK	3/8 IN	1.0 CM
WEIGHT	1.4LBS	0.6 KGS

**1044** **FB**  
NEW

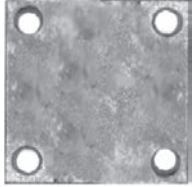

HEIGHT	4 IN	0.2 CM
WIDTH	4 IN	10.2 CM
THICK	3/8 IN	1.0 CM
WEIGHT	0.6 LBS	0.3 KGS

**1033** **FB**  
NEW

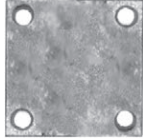

HEIGHT	3 IN	7.6 CM
WIDTH	3 IN	7.6 CM
THICK	3/8 IN	1.0 CM
WEIGHT	0.3 LBS	0.2 KGS

NOTE : ALL CORNER HOLES IN THE PLATES ARE TAPERED. (1/2 INCH DIAMETER AT THE TOP AND ARE 3/8 IN. DIAMETER AT THE BOTTOM).

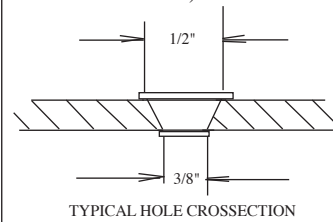

WELDABLE ALUMINUM BUTT HINGES

**1091**  
NEW

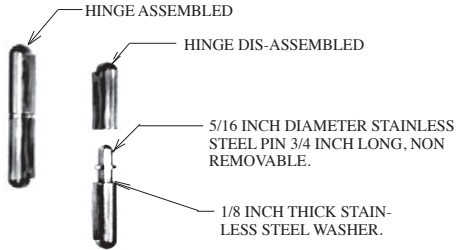

LIFT OFF HINGE, UNIVERSAL LEFT AND RIGHT HAND.

HINGE IS 3 5/32 INCHES TALL. HEIGHT, INCLUDING WELD TAB IS 5/8 INCHES. NOMINAL DIAMETER IS 1/2 INCH.

**1098/1099**  
NEW

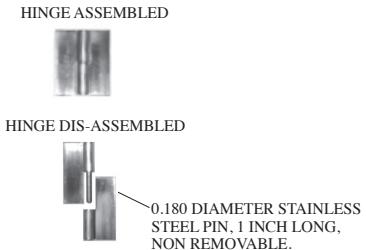

LIFT OFF HINGE, LEFT HAND AND RIGHT HAND.

RIGHT HAND LIFT OFF HINGE IS SHOWN (NO. 1099), LEFT HAND HINGE NOT SHOWN (NO. 1098). BOTH HINGES ARE 2 INCHES HIGH AND 1 3/4 INCHES WIDE BY 3/8 INCH HIGH.

**1095**  
NEW

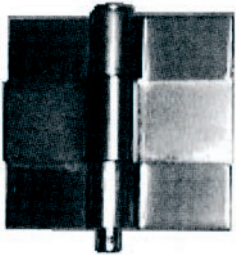

PIN IS 1/2" DIAMETER, GALVANIZED STEEL. REMOVABLE. LEAF IS 0.180 INCH THICK.

HEIGHT	5 IN	12.7 CM
WIDTH	4 3/4 IN	12.1 CM
THICK	1 IN	2.5 CM
WEIGHT	0.9 LB	0.43 KG

**1093**  
NEW



PIN IS 5/32" DIAMETER, ALUMINUM, NON REMOVABLE. LEAF IS 0.090 INCH THICK.

HEIGHT	3 IN	7.6 CM
WIDTH	3 IN	7.6 CM
THICK	3/8 IN	1.0 CM
WEIGHT	0.1 LB	0.05 KG

**1092**  
NEW



PIN IS 1/8" DIAMETER, ALUMINUM, NON REMOVABLE. LEAF IS 0.050 INCH THICK.

HEIGHT	2 IN	5.9 CM
WIDTH	2 IN	5.9 CM
THICK	1/4 IN	0.6 CM
WEIGHT	0.01 LB	0.005 KG

**2080**  
OLD H208 AL



WELDABLE TAB

HEIGHT	2 5/8 IN	6.7 CM
WIDTH	2 IN	5.1 CM
THICK	1/4 IN	0.6 CM
WEIGHT	0.1 LB	0.05 KG





# ALUMINUM CASTINGS

Toll Free (800) 527-1318

(972) 286-2368

Fax: (972) 557-4727

Section:

Late Additions

**8016** 1 1/2"  
NEW

TOP VIEW

SIDE VIEW

STUB IS 3/4 INCH LONG BY 1 3/8 INCHES SQUARE AND TAPERED. SEAT IS 2 1/8 INCHES SQUARE.

HEIGHT	1 3/8 IN	3.5 CM
WIDTH	2 1/8 IN	5.4 CM
THICK	2 1/8 IN	5.4 CM
WEIGHT	0.2 LBS	0.1 KGS

**1400** 1"  
NEW

TOP VIEW

SIDE VIEW

TUBE SEAT IS 2 INCHES SQUARE. STUB IS 1 INCH SQUARE ("X" SHAPED") AND 1/4 INCH LONG.

HEIGHT	2 IN	5.1 CM
WIDTH	2 IN	5.1 CM
THICK	1 3/8 IN	3.5 CM
WEIGHT	0.1 LBS	0.05 KGS

**8298** 1/2"  
NEW

HEIGHT	6 1/4 IN	15.9 CM
WIDTH	3 1/2 IN	8.9 CM
THICK	1 1/4 IN	3.2 CM
WEIGHT	0.4 LBS	0.2 KGS

**9298** **DF**

SEE PAGE 105

NOTE: THIS PIECE IN DEVELOPMENT. IF INTERESTED PLEASE CONTACT US BY PHONE.

HEIGHT 36 IN 91.4 CM  
WIDTH 12 IN 28.6 CM  
THICK 1 7/8 IN 4.8 CM  
WEIGHT 5.1 LBS 2.3 KGS

CENTERLINE OF 7/8 INCH SQUARE HOLE IN THIS PIECE. (TOP AND BOTTOM)  
SCALE: 2 INCHES = 1 FOOT

**8030** 1"

INQUIRY

STUB IS 1/2 INCH LONG BY 1 INCH SQUARE AND TAPERED. SEAT IS 1 3/4 INCHES SQUARE.

HEIGHT	6 1/2 IN	16.5 CM
WIDTH	3 3/4 IN	9.5 CM
THICK	1 3/4 IN	4.4 CM
WEIGHT	0.9 LBS	0.4 KGS

**8031** 1"

INQUIRY

STUB IS 1/2 INCH LONG BY 1 INCH SQUARE AND TAPERED. SEAT IS 1 3/4 INCHES SQUARE.

HEIGHT	7 7/8 IN	20.0 CM
WIDTH	3 7/8 IN	9.8 CM
THICK	1 3/4 IN	4.4 CM
WEIGHT	0.9 LBS	0.4 KGS

**BASKET**

AVAILABLE

NOTE: THIS PIECE IN DEVELOPMENT. IF INTERESTED PLEASE CONTACT US BY PHONE.

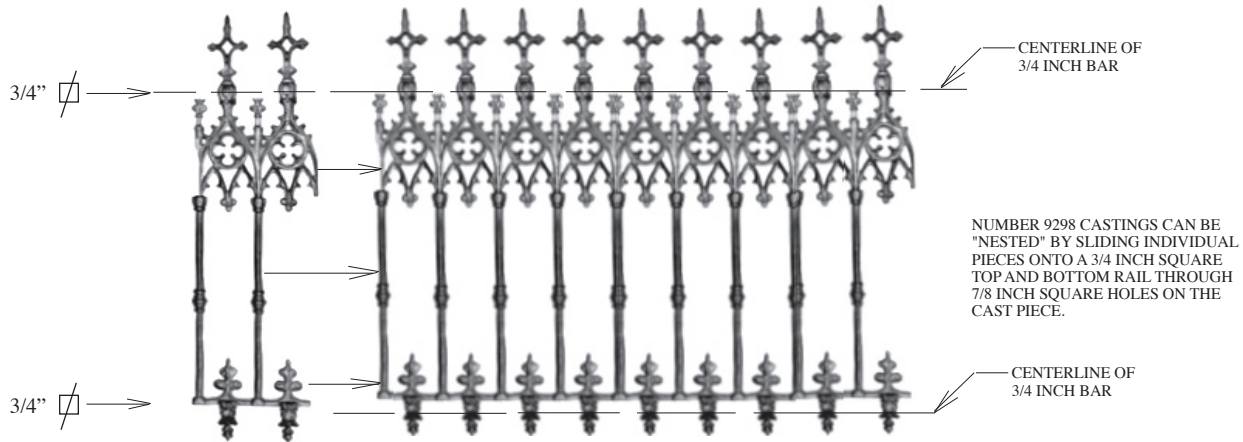

REVISION DATE: 02/28/95

SCALE: 3 INCHES = 1 FOOT UNLESS NOTED

## Technical Definitions , Abbreviations and Symbols

### Symbols:

- ] x [ Normally used in connection with picket castings to indicate the width of the bar ("x" inches) onto which the picket casting will fit.
- ⊠ indicates the size of the hole in the casting and will fit onto a square bar of that size. The opening will be oversized. If the tubing or bar size designated is 1 inch square the hole will typically be 1/16 inch oversized.
- ⊠ indicates the size of tubing into which the casting will fit. If the tubing size designated is 1 inch square the stub on the casting will be typically 7/8 inch square, tapered and will wedge into a 1 inch tube that has a nominal 16 gage wall thickness.
- ⊙ indicates the size of the hole in the casting and will fit onto a round tube or bar of that size. The opening will be oversized. If the tubing or bar size designated is 1 inch round the hole will typically be 1/16 inch oversized.
- ⊙ indicates the size of tubing into which the casting will fit. If the tubing size designated is 1 inch round the stub on the casting will be typically 7/8 inch round, tapered and will wedge into a 1 inch tube that has a nominal 16 gage wall thickness.

### Definitions:

1. **Clips** -- Steel pieces (clips) are cast into the aluminum casting in order to be able to weld the casting to steel. The clips can be placed in the casting at almost any location and are of two basic arrangements.

**Flat clips** -- Those clips that when the casting is placed on a flat surface the clips are parallel to the surface of the casting.



**Vertical Clips** -- Those clips called vertical clips or "pushed clips" or "ninety degree clips", and are clips that when the casting is placed on a flat surface the clips are vertical to the casting.

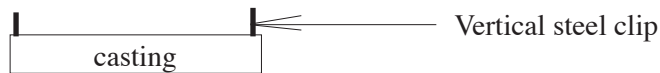

2. **Drafts** -- That slope on the vertical face of a pattern. A positive draft allows the pattern to be pulled cleanly from the sand in the mold.

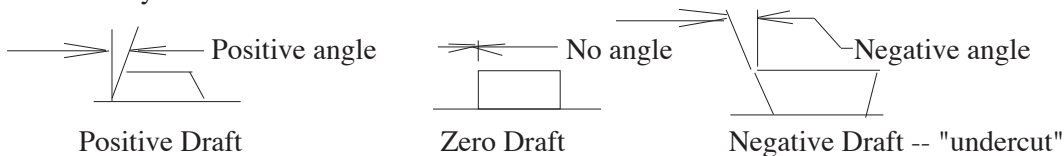

3. **Loose** -- When a casting is molded "loose" it is done without the support of a pattern board. Although the individual piece price is higher, a few items can be made at a lower per piece cost by avoiding the more expensive cost of permanent tooling. However pieces made by this method do not have a quality as good as those made with permanent tooling.
4. **Master Pattern** -- The original piece. A carving or sample from which the permanent production tooling will be created

## Technical Definitions , Abbreviations and Symbols (Continued)

### Definitions

5. **Match Plate** -- The permanent production tooling which has been created from the master pattern.
6. **Nested** -- the nesting concept has two or more castings that have been designed to interlock on a bar to provide a continuous design when they are placed (nested) in a series.
7. **Parting Line** -- That line developed on the casting where the two halves of a sand mold come together. Normally the widest part of the casting's cross section.

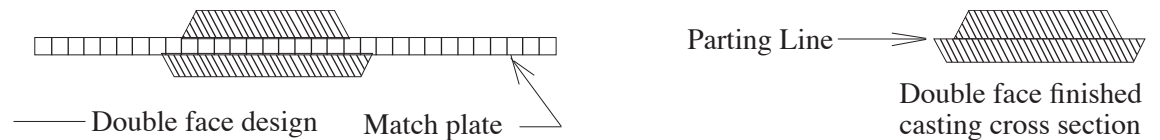

8. **Stub** -- The stub is that part of a spear or finial that fits into a tube opening. The stub is most always tapered and contains drafts. i.e. the stub may be a tapered 7/8 inch square to fit into a 1 inch tubing that has 1/16 inch wall thickness,

### Abbreviations:

1. **lbs** -- Weight of the casting in pounds.
2. **Kgs** -- Weight of the casting in kilograms.
3. **in** -- Dimension of the casting in inches.
4. **cm** -- Dimension of the casting in centimeters.
5. **DF** -- Double face. Indicates that the casting has the similar type of surface and design on both sides of the piece.



6. **SF** -- Single face. Indicates that the casting may have some detail on the back side of the piece, but much less than the front side of the piece.



7. **FB** -- Flat back. Indicates that the casting is flat on the back side.



8. **SBO** -- Side Backed Out. Indicates that the casting has been lightened by "scooping" out the back side of the piece. The back side has no detail or design.



Section:

Toll Free (800) 527-1318

Terms and  
Conditions

(972) 286-2368

Fax: (972) 557-4727



## Terms and Conditions of Sale

### "Quality Castings on Time"

#### **1. Payment Terms --**

Established accounts net 30 days.

New accounts are shipped COD until a credit application has been submitted and approved. A credit application (faxable) is enclosed, see page 103. Credit evaluations can be made within a week.

No statements will be sent. Please pay from invoice rendered.

#### **2. Shipping --**

All merchandise is shipped FOB factory in Mesquite, Texas, with goods being at the transit risk of the purchaser.

Shipping is via specified air carrier, common carrier, motor express, bus, or UPS.

#### **3. Warranty --**

Material and workmanship of aluminum castings upon receipt. Castings received in an unacceptable condition will be replaced.

Castings are made with substantial hand working in the forming and cleaning process.

Because of this every casting is not exactly the same, and there will be minor differences between castings of the same design.

#### **4. Damages/Shortages --**

All merchandise is shipped on pallets, pallet boxes, in fiber drums, boxes, or cardboard wrapped to reduce the impact of rough handling during shipment.

Any claims for damages are the responsibility of the purchaser and must be filed against the carrier at the receiving end. Alloy Casting will assist at any time.

#### **5. Returned Goods --**

No merchandise is to be returned without prior approval. A credit or check will be issued upon receipt of the goods at the factory in Mesquite, Texas. There is no restocking charge for standard inventory items.

#### **6 Pricing --**

All prices will be subject to change without advance notice. Ask for price information at time of placing the order. All price commitments will be honored.

#### **7. Minimum Order --**

There is no minimum order. All orders will receive immediate personal attention and will be shipped promptly.

#### **8. Back Orders --**

All casting orders will be shipped complete.

If an expedited order is required, a partial order will be shipped upon request.

#### **9. M S D S --**

Material Safety Data Sheets are available upon request.





# Alloy Casting

ALUMINUM CASTINGS

Toll Free (800) 527-1318

(972) 286-2368

Fax: (972) 557-4727

Section:  
**Credit Application**

## "Quality Castings on Time"

### Credit Application

Business Name \_\_\_\_\_ Partnership \_\_\_\_\_

Business Address \_\_\_\_\_ Proprietorship \_\_\_\_\_  
Corporation \_\_\_\_\_

Phone ( ) \_\_\_\_\_

Name of Key Officer or Principal \_\_\_\_\_

Home Address \_\_\_\_\_

Home Phone ( ) \_\_\_\_\_ Driver's License \_\_\_\_\_

Number of years in Present Business \_\_\_\_\_

Bank Reference: Name of Bank \_\_\_\_\_

Address \_\_\_\_\_

Phone ( ) \_\_\_\_\_

Name of Bank Officer \_\_\_\_\_

Trade References:

(1)

(2)

(3)

(4)

Company Name \_\_\_\_\_

Address \_\_\_\_\_

Fax Number ( ) \_\_\_\_\_ ( ) \_\_\_\_\_ ( ) \_\_\_\_\_ ( ) \_\_\_\_\_

Person to Contact:

\_\_\_\_\_

Date Applied \_\_\_\_\_

**Signature**

Toll Free (800) 527-1318

(972) 286-2368

Fax: (972) 557-4727



**Alloy Casting**

**ALUMINUM CASTINGS**

DOUBLE FACED



**4478**

HEIGHT: 13 3/4" 34.9 cm  
 WIDTH: 12" 30.5 cm  
 THICK: 3/4" 1.9 cm  
 WEIGHT: 2.3 lbs 5.8 kgs

FLAT BACK



**3757/3777**

HEIGHT: 15 1/2" 39.4 cm  
 WIDTH: 11 1/2" 29.2 cm  
 THICK: 1/4" 0.64 cm  
 WEIGHT: 1.5 lbs 3.8 kgs

SIDE BACKED OUT

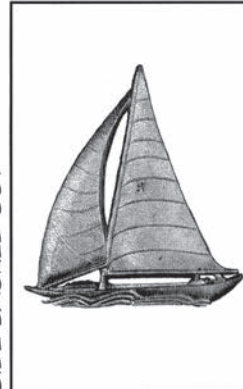

**4489**

HEIGHT: 11 1/2" 29.2 cm  
 WIDTH: 10 3/8" 26.4 cm  
 THICK: 1/2" 1.27 cm  
 WEIGHT: 1.3 lbs 3.3 kgs

SIDE BACKED OUT

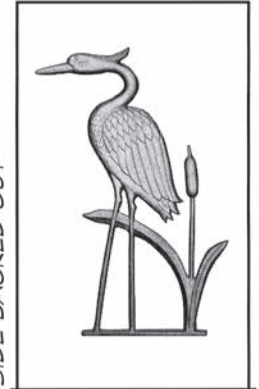

**4463**

HEIGHT: 21.63" 54.94 cm  
 WIDTH: 12" 30.48 cm  
 THICK: 0.75" 1.91 cm  
 WEIGHT: 2.2 lbs 5.59 kgs

PELICAN PAIR

FLAT BACK

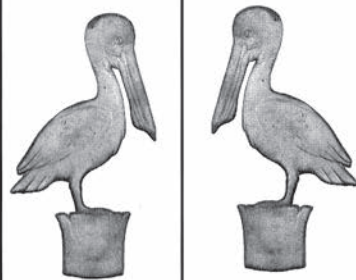

**3755/3775**

HEIGHT: 16 3/4" 42.6 cm  
 WIDTH: 9 1/4" 23.5 cm  
 THICK: 1/4" 0.64 cm  
 WEIGHT: 1.3 lbs 3.3 kgs

FLAT BACK

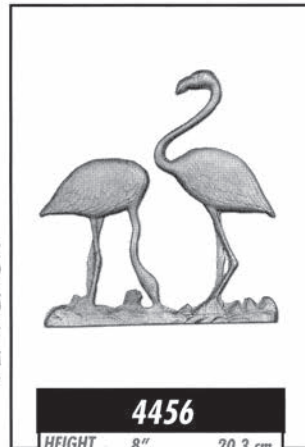

**4456**

HEIGHT: 8" 20.3 cm  
 WIDTH: 8 1/2" 21.6 cm  
 THICK: 5/8" 1.6 cm  
 WEIGHT: 0.9 lbs 2.29 kgs

FLAT BACK

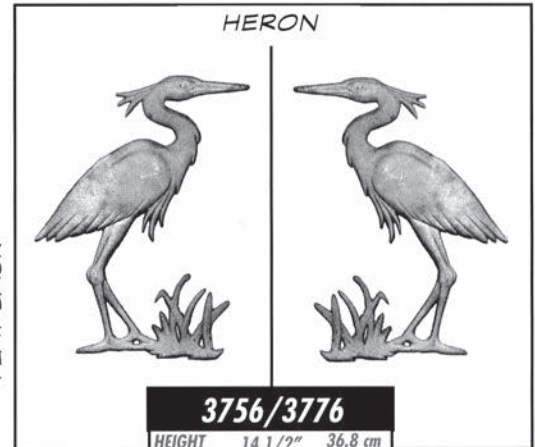

HERON

**3756/3776**

HEIGHT: 14 1/2" 36.8 cm  
 WIDTH: 11 1/2" 29.2 cm  
 THICK: 3/8" 0.97 cm  
 WEIGHT: 1.2 lbs 3.05 kgs

Revision Date: 05/01/99

DOUBLE FACED

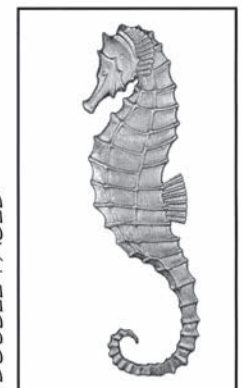

**4468**

HEIGHT: 21 1/2" 54.6 cm  
 WIDTH: 6" 15.2 cm  
 THICK: 3/4" 1.9 cm  
 WEIGHT: 3.1 lbs 7.9 kgs

FLAT BACK

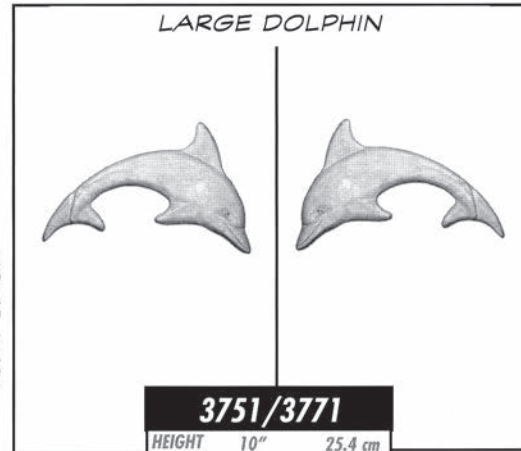

LARGE DOLPHIN

**3751/3771**

HEIGHT: 10" 25.4 cm  
 WIDTH: 15 1/2" 39.4 cm  
 THICK: 1/4" 0.64 cm  
 WEIGHT: 1.5 lbs 3.81 kgs

FLAT BACK

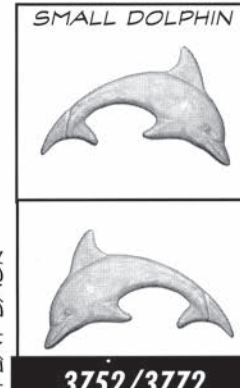

SMALL DOLPHIN

**3752/3772**

Top / Bottom  
 HEIGHT: 6 1/2" 16.5 cm  
 WIDTH: 10" 25.4 cm  
 THICK: 1/4" 0.64 cm  
 WEIGHT: 0.6 lbs 1.5 kgs

DOUBLE FACED



SAIL FISH

**4471**

HEIGHT: 8 1/4" 21.0 cm  
 WIDTH: 8 3/4" 22.2 cm  
 THICK: 5/8" 1.6 cm  
 WEIGHT: 0.9 lbs 2.29 kgs



# Alloy Casting



## ALUMINUM CASTINGS

Toll Free (800) 527-1318

(972) 286-2368

Fax: (972) 557-4727

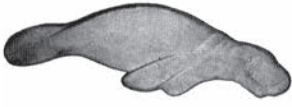
**LARGE MANATEE**

**3753/3773**  
Top /Bottom

HEIGHT	5 1/2"	13.97 cm
WIDTH:	17 3/4"	45.09 cm
THICK:	1/4"	0.64 cm
WEIGHT:	1.0 lbs	2.54 kgs

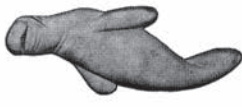

**SMALL MANATEE**

**3754/3774**  
Top /Bottom

HEIGHT:	4 1/2"	11.43 cm
WIDTH:	11"	27.9 cm
THICK:	1/4"	0.64 cm
WEIGHT:	0.5 lbs	1.27 kgs

**STAINLESS STEEL SLIDE LATCH**

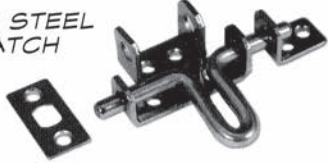
**1139**

HEIGHT:	3.0"	7.62 cm
WIDTH:	1.0"	2.54 cm
THICK:		
WEIGHT:		

2 5/8"  $\phi$



**993**

HEIGHT	5 3/4"	14.61 cm
WIDTH:	5 1/4" DIA	13.34 cm
WEIGHT:	2.4"	6.10 kgs

for 2 piece set

3"  $\phi$



**34**

HEIGHT:	4 3/4"	12.07 cm
WIDTH:	5 5/8" DIA	14.29 cm
WEIGHT:	2.2 lbs	5.59 kgs

for 2 piece set

3"  $\phi$



**35**

HEIGHT:	3 3/8"	8.57 cm
WIDTH:	4 7/8" DIA	12.38 cm
WEIGHT:	0.6 lbs	1.52 kgs

for 2 piece set

**ALUMINUM LATCH**



**1138**

HEIGHT:	3.0"	7.62 cm
WIDTH:	1.0"	2.54 cm
THICK:		
WEIGHT:		

## ALUMINUM BASKETS

BOTH ENDS ARE 1 1/4"



BAR STOCK IS MADE FROM 5/8"  $\square$

**1125**

HEIGHT	8 3/4"	22.23 cm
WIDTH:	3 3/4" DIA	9.53 cm
THICK:	3 3/4"	9.53 cm
WEIGHT:	1.5 lbs	3.81 kgs

BOTH ENDS ARE 1" SQ



BASKET IS MADE FROM 1/2" BAR STOCK

**1100**

HEIGHT	8 3/4"	22.23 cm
WIDTH:	3 3/4" DIA	9.53 cm
THICK:	3 3/4"	9.53 cm
WEIGHT:	1.0 lbs	2.54 kgs

BOTH ENDS ARE 3/4" SQ. AND MATCH UP TO A 3/4" SQ. PICKET



3/4"  $\square$  ENDS

BASKET IS MADE FROM 3/8" BAR STOCK

**1340**

HEIGHT	7"	17.8 cm
WIDTH:	2 1/4" DIA	5.7 cm
THICK:	2 1/4"	5.7 cm
WEIGHT:	0.4 lbs	0.2 kgs

BOTH ENDS ARE 5/8" SQ



BASKET IS MADE FROM 5/16" BAR STOCK

**1580**

HEIGHT	7"	17.8 cm
WIDTH:	2 1/4"	5.7 cm
THICK:	2 1/4"	5.7 cm
WEIGHT:	0.4 lbs	0.2 kgs

BOTH ENDS ARE 1/2" SQ



BASKET IS MADE FROM 1/4" BAR STOCK

**1120**

HEIGHT	7"	17.78 cm
WIDTH:	2 1/4" DIA	5.72 cm
THICK:	2 1/4"	5.72 cm
WEIGHT:	0.6 lbs	0.3 kgs

Revision Date: 05/01/99



Toll Free (800) 527-1318

(972) 286-2368

Fax: (972) 557-4727



**ALUMINUM CASTINGS**

**1090**

HEIGHT: 5"	12.7 cm
WIDTH: 10"	25.4 cm
THICK:	
WEIGHT:	

**1132**

HEIGHT: 5.5"	13.97 cm
WIDTH: 11"	27.9 cm
THICK: 1.75"	4.45 cm
WEIGHT: 1.0 lbs	2.54 kgs

**1191**

HEIGHT: 5.88"	14.94 cm
WIDTH: 0.75" DIA	1.91 cm
THICK:	
WEIGHT:	

4" WELDABLE BUTT HINGE

Non removable Aluminum Pin  
3/16" DIA  
Leaf 1/8" Thick

**1094**

HEIGHT: 4"	10.16 cm
WIDTH: 4"	10.16 cm
THICK: 1/2"	1.27 cm
WEIGHT: 0.2 lbs	0.51 kgs

SIMPLEX LOCK BOX

**1197**

HEIGHT: 5.5"	13.97 cm
WIDTH: 4"	10.2 cm
THICK: 1.75"	4.45 cm
WEIGHT: 0.5 lbs	1.27 kgs

ALUMINUM BLOCK HINGE  
1 1/4" X 1 3/4" RECTANGULAR

S.S. BALL  
5/8" DIA

5/8" DIA STAINLESS STEEL PIN

3 1/2"

GREASE FITTING

**1087**

HEIGHT: 7 1/8"	18.11 cm
WIDTH: 1 3/4"	4.45 cm
THICK: 1 1/4"	3.18 cm
WEIGHT: 1.8 lbs	4.57 kgs

SIMPLEX LOCK BOX

**1297**

HEIGHT: 8.5"	21.59 cm
WIDTH: 4.63"	11.76 cm
THICK: 1.75"	4.45 cm
WEIGHT: 0.8 lbs	2.03 kgs

ALUMINUM BLOCK HINGE 1 1/2"

5/8" DIA S.S. BALL

5/8" DIA STAINLESS PIN

3"

GREASE FITTING

**1086**

HEIGHT: 6 1/8"	15.57 cm
WIDTH: 1 1/2"	3.81 cm
THICK: 1 1/2"	3.81 cm
WEIGHT: 1.5 lbs	3.81 kgs

Revision Date: 05/01/99





# Alloy Casting

## ALUMINUM CASTINGS

Toll Free (800) 527-1318

(972) 286-2368

Fax: (972) 557-4727



<b>1122</b>	
HEIGHT	1" 2.54 cm
WIDTH:	3 5/8" 9.22 cm
THICK:	2 1/4" 5.72 cm
WEIGHT:	0.1 lbs 0.25 kgs

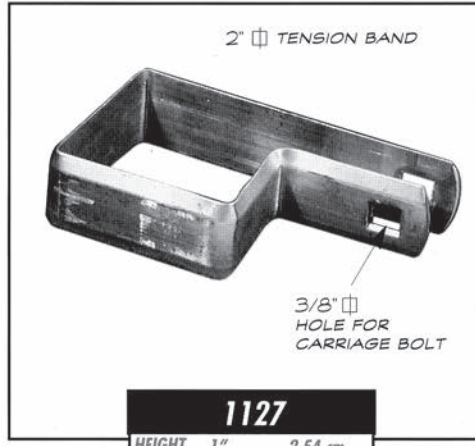

<b>1127</b>	
HEIGHT	1" 2.54 cm
WIDTH:	4" 10.16 cm
THICK:	2 1/4" 5.72 cm
WEIGHT:	0.1 lbs 0.25 kgs



<b>1123</b>	
HEIGHT	1 1/4" 3.18 cm
WIDTH:	9" 22.86 cm
THICK:	5" 12.7 cm
WEIGHT:	0.4 lbs 1.02 kgs

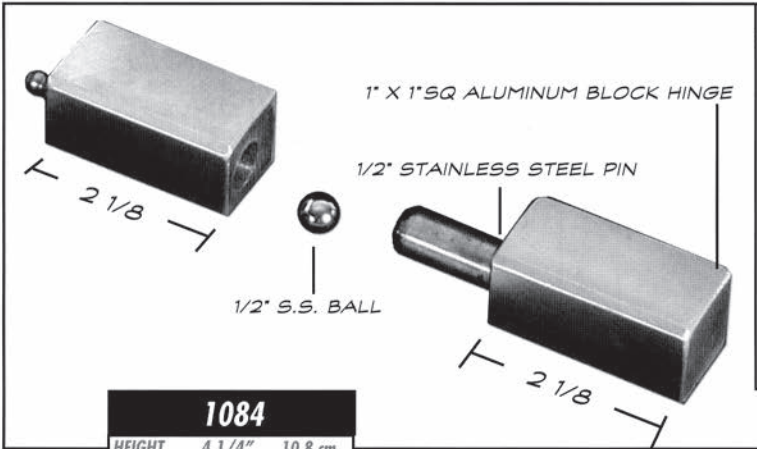

<b>1084</b>	
HEIGHT	4 1/4" 10.8 cm
WIDTH:	1" 2.54 cm
THICK:	1" 2.54 cm
WEIGHT:	0.5 lbs 1.27 kgs

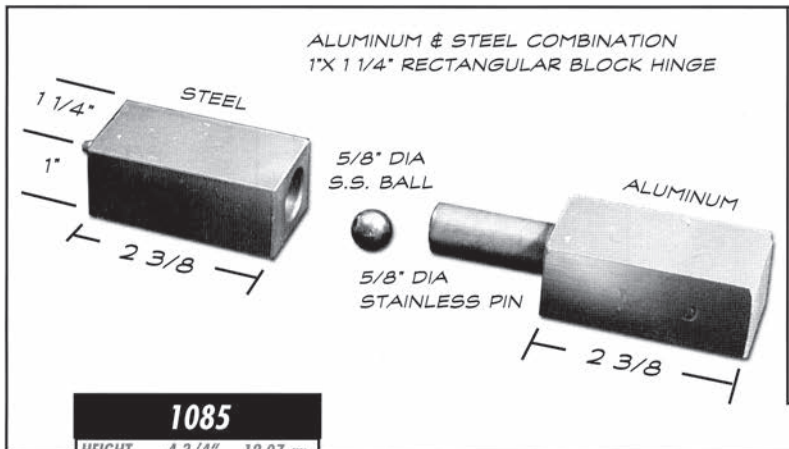
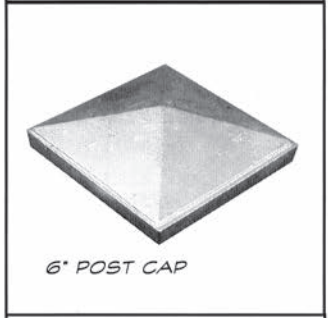
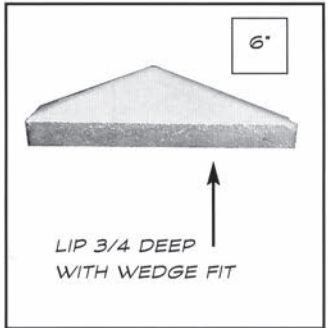
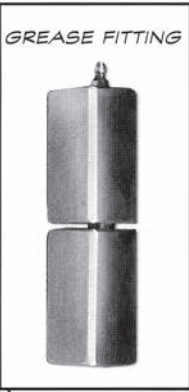

<b>1085</b>	
HEIGHT	4 3/4" 12.07 cm
WIDTH:	1 1/4" 3.18 cm
THICK:	1" 2.54 cm
WEIGHT:	1.2 lbs 3.05 kgs

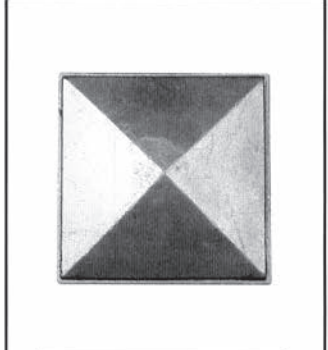
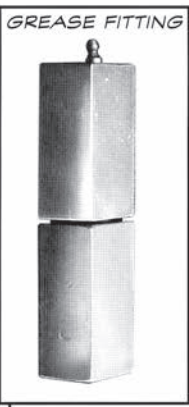

<b>3306</b>	
HEIGHT	2" 5.08 cm
WIDTH:	6 3/4" 17.15 cm
DEPTH:	6 3/4" 17.15 cm
WEIGHT:	1.3 lbs 3.30 kgs

Revision Date: 05/01/99

Toll Free (800) 527-1318

(972) 286-2368

Fax: (972) 557-4727



ALUMINUM CASTINGS

10" BALL AND BASE

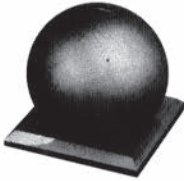

**1710**

HEIGHT:	
WIDTH:	
THICK:	
WEIGHT:	18.8 lbs 47.75 kgs

BASE FOR 10" BALL

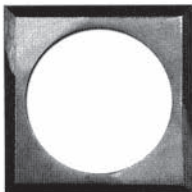

**1711**

HEIGHT:	10 3/8" 26.35 cm
WIDTH:	10 3/8" 26.35 cm
THICK:	1" 2.54 cm
WEIGHT:	3.0 lbs 7.62 kgs

10" BALL

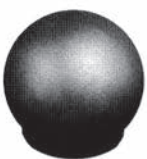

**1712**

HEIGHT:	8 1/2" 21.59 cm
WIDTH:	10" DIA 25.4 cm
THICK:	1/2" wall 1.27 cm
WEIGHT:	15.8 lbs 40.13 kgs

STAMPED ALUMINUM LEAVES 1/16" FLAT



DOUBLE FACED

**NOT AVAILABLE**

**1271**

HEIGHT:	5 1/2" 13.97 cm
WIDTH:	3" 7.62 cm
THICK:	1/16" 0.16 cm

STAMPED ALUMINUM LEAVES 1/16" FLAT



DOUBLE FACED

**NOT AVAILABLE**

**1272**

HEIGHT:	5 1/2" 13.97 cm
WIDTH:	3" 7.62 cm
THICK:	1/16" 0.16 cm

6" BALL AND BASE

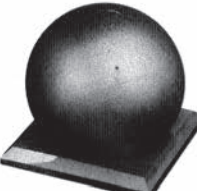

**1760**

HEIGHT:	
WIDTH:	
THICK:	
WEIGHT:	5.8 lbs 14.73 kgs

BASE FOR 6" BALL

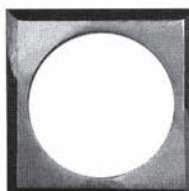

**1761**

HEIGHT:	6" 15.24 cm
WIDTH:	6" 15.24 cm
THICK:	5/8" 0.63 cm
WEIGHT:	1.0 lbs 2.54 kgs

6" BALL

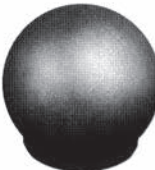

**1762**

HEIGHT:	4 1/2" 11.43 cm
WIDTH:	6" DIA 15.24 cm
THICK:	1/2" wall 1.27 cm
WEIGHT:	4.8 lbs 12.19 kgs

STAMPED ALUMINUM LEAVES 1/16" FLAT



DOUBLE FACED

**NOT AVAILABLE**

**1276**

HEIGHT:	9" 22.86 cm
WIDTH:	2 7/8" 7.30 cm
THICK:	1/16" 0.16 cm

STAMPED ALUMINUM LEAVES 1/16" CURVED 1/2" HIGH



DOUBLE FACED

**NOT AVAILABLE**

**1274**

HEIGHT:	9" 22.86 cm
WIDTH:	2 5/8" 6.67 cm
THICK:	1/16" 0.16 cm



5/8"  $\phi$  STUB

**2779**

HEIGHT:	6" 15.24 cm
WIDTH:	2.5" 6.35 cm
THICK:	1.0" 2.54 cm
WEIGHT:	0.3 lbs 0.76 kgs



3/4"  $\phi$  STUB

**2777**

HEIGHT:	5.38" 13.67 cm
WIDTH:	2.75" 6.99 cm
THICK:	0.88" 2.24 cm
WEIGHT:	0.3 lbs 0.76 kgs



1/2"  $\phi$  STUB

**2776**

HEIGHT:	4.38" 11.13 cm
WIDTH:	2.25" 5.72 cm
THICK:	0.75" 1.91 cm
WEIGHT:	0.15 lbs 0.38 kgs

STAMPED ALUMINUM LEAVES 1/16" FLAT



DOUBLE FACED

**NOT AVAILABLE**

**1275**

HEIGHT:	9 1/2" 24.13 cm
WIDTH:	3 1/2" 8.89 cm
THICK:	1/16" 0.16 cm

STAMPED ALUMINUM LEAVES 1/16" FLAT



DOUBLE FACED

**NOT AVAILABLE**

**1278**

HEIGHT:	4 3/4" 12.07 cm
WIDTH:	4" 10.16 cm
THICK:	1/16" 0.16 cm

Revision Date: 05/01/99



# Alloy Casting

## ALUMINUM CASTINGS

Toll Free (800) 527-1318

(972) 286-2368

Fax: (972) 557-4727

FORGED ALUMINUM  
LEAVES 1/8" THICK

**2711**

HEIGHT: 4.75"	12.07 cm
WIDTH: 2.0"	5.08 cm
THICK: 0.125"	0.32 cm
DEPTH: 0.75"	1.91 cm
WEIGHT: 0.1 lbs	0.25 kgs

FORGED ALUMINUM  
LEAVES 1/8" THICK

**2712**

HEIGHT: 4.75"	12.07 cm
WIDTH: 2.0"	5.08 cm
THICK: 0.125"	0.32 cm
DEPTH: 0.75"	1.91 cm
WEIGHT: 0.1 lbs	0.25 kgs

**2703**

HEIGHT: 8.88"	22.56 cm
WIDTH: 4.75"	12.07 cm
THICK: 0.5"	1.27 cm
WEIGHT: 0.3 lbs	0.76 kgs

**2704**

HEIGHT: 11.44"	29.06 cm
WIDTH: 4.75"	12.07 cm
THICK: 0.5"	1.27 cm
WEIGHT: 0.4 lbs	1.02 kgs

**2705**

HEIGHT: 14.75"	37.47 cm
WIDTH: 4.75"	12.07 cm
THICK: 0.5"	1.27 cm
WEIGHT: 0.2 lbs	0.51 kgs

FORGED ALUMINUM  
LEAVES 1/8" THICK

**2714**

HEIGHT: 2.5"	6.35 cm
WIDTH: 2.25"	5.72 cm
THICK: 0.094"	0.24 cm
DEPTH: 0.88"	2.24 cm
WEIGHT: 0.1 lbs	0.25 kgs

FORGED ALUMINUM  
LEAVES 1/8" THICK

**2715**

HEIGHT: 2.5"	6.35 cm
WIDTH: 2.25"	5.72 cm
THICK: 0.094"	0.24 cm
DEPTH: 0.88"	2.24 cm
WEIGHT: 0.1 lbs	0.25 kgs

**2709**

HEIGHT: 7.25"	18.42 cm
WIDTH: 3.5"	8.89 cm
THICK: 0.5"	1.27 cm
WEIGHT: 0.3 lbs	0.76 kgs

**2710**

HEIGHT: 4.5"	11.43 cm
WIDTH: 2.5"	6.35 cm
THICK: 0.5"	1.27 cm
WEIGHT: 0.15 lbs	0.38 kgs

**2721**

HEIGHT: 5.5"	13.97 cm
WIDTH: 11"	27.9 cm
THICK: 1.75"	4.45 cm
WEIGHT: 1.0 lbs	2.54 kgs

**1466**

HEIGHT: 240"	609.6 cm
WIDTH: 1 3/4"	4.45 cm
THICK: 1/4"	0.64 cm

**1464**

HEIGHT: 240"	609.6 cm
WIDTH: 1 3/4"	4.45 cm
THICK: 1/4"	0.64 cm

**2671**

HEIGHT: 34 1/4"	87 cm
WIDTH: 13 3/4"	34.93 cm
THICK: 1 1/4"	3.18 cm
WEIGHT: 1.8 lbs	4.57 kgs

**2672**

HEIGHT: 28 5/16"	71.91 cm
WIDTH: 9 1/4"	23.50 cm
THICK: 1 1/4"	3.18 cm
WEIGHT: 1.1 lbs	2.79 kgs

Revision Date: 05/01/99



Toll Free (800) 527-1318

(972) 286-2368

Fax: (972) 557-4727



**ALUMINUM CASTINGS**



**1172**

HEIGHT: 72" 182.9 cm  
WIDTH: 2" 5.08 cm  
THICK: 3/8" 0.36 cm  
WEIGHT:

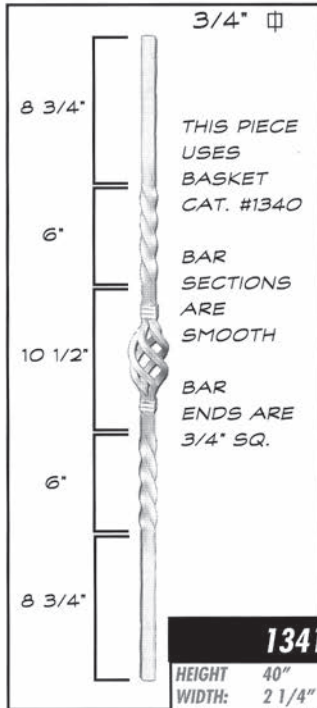

**1341**

HEIGHT 40" 101.6 cm  
WIDTH: 2 1/4" 5.7 cm  
THICK: 2 1/4" 5.7 cm  
WEIGHT: 2.3 lbs 5.84 kgs

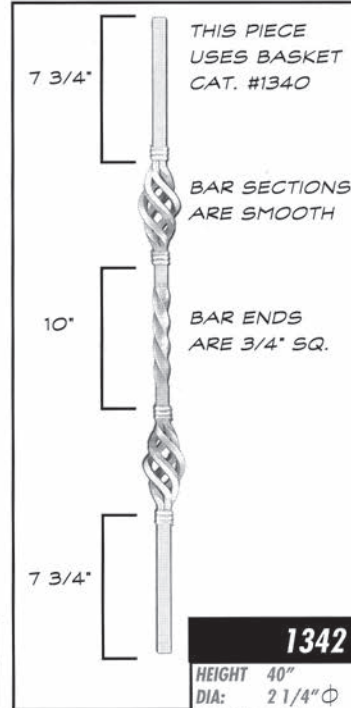

**1342**

HEIGHT 40" 101.6 cm  
DIA: 2 1/4"  $\Phi$  5.7 cm  
WEIGHT: 2.5 lbs 6.35 kgs

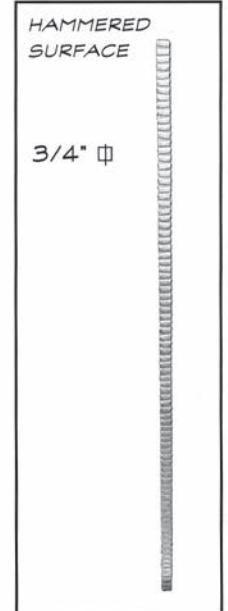

**1347**

HEIGHT 40" 101.6 cm  
WIDTH: 3/4" 1.91 cm  
THICK: 3/4" 1.91 cm  
WEIGHT: 2.2 lbs 5.59 kgs



**1131**

HEIGHT 1" 2.54 cm  
WIDTH: 4" 10.16 cm  
THICK: 4" 10.16 cm  
WEIGHT: 0.1 lbs 0.25 kgs



**1134**

HEIGHT 2" 5.08 cm  
WIDTH: 13" 33.02 cm  
THICK: 3/4" 1.91 cm  
WEIGHT: 0.3 lbs 0.76 kgs

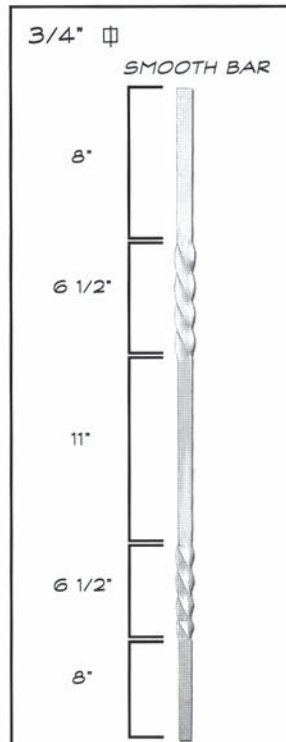

**1348**

HEIGHT 40" 101.6 cm  
WIDTH: 1" 2.54 cm  
THICK: 1" 2.54 cm  
WEIGHT: 2.2 lbs 5.59 kgs

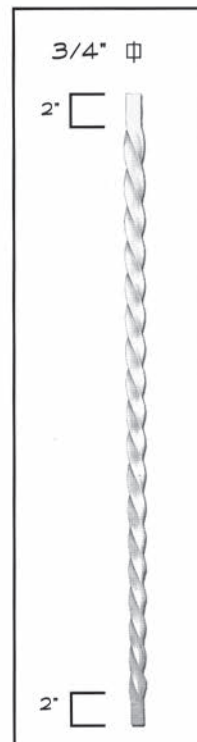

**1349**

HEIGHT 40" 101.6 cm  
WIDTH: 1" 2.54 cm  
THICK: 1" 2.54 cm  
WEIGHT: 2.2 lbs 5.59 kgs

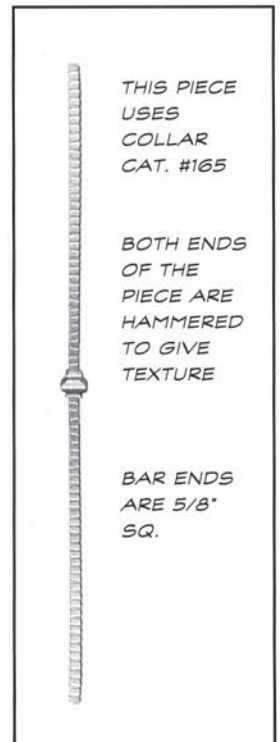

**1583**

HEIGHT 40" 101.6 cm  
WIDTH: 2 1/4" 5.7 cm  
THICK: 2 1/4" 5.7 cm  
WEIGHT: 1.5 lbs 0.7 kgs

Revision Date: 05/01/99





# Alloy Casting

## ALUMINUM CASTINGS

Toll Free (800) 527-1318

(972) 286-2368

Fax: (972) 557-4727

THIS PIECE USES BASKET CAT. #1580

BASKET IS MADE FROM 4 PIECES OF 5/16" ALUMINUM

BAR SECTIONS ARE SMOOTH

BAR ENDS ARE 5/8" SQ.

**1581**

HEIGHT	40"	101.6 cm
WIDTH:	2 1/4" DIA AT BASKET	5.7 cm
THICK:	2 1/4" DIA AT BASKET	5.7 cm
WEIGHT:	1.6 lbs	4.06 kgs

THIS PIECE USES BASKET CAT. #1580

BASKET IS MADE FROM 4 PIECES OF 5/16" ALUMINUM

BAR SECTIONS ARE SMOOTH

BAR ENDS ARE 5/8" SQ.

**1582**

HEIGHT	40"	101.6 cm
WIDTH:	2 1/4" DIA AT BASKET	5.7 cm
THICK:	2 1/4" DIA AT BASKET	5.7 cm
WEIGHT:	1.7 lbs	4.32 kgs

THIS PIECE USES BASKETCAT. 1580

BOTH ENDS OF THE PIECE ARE HAMMERED TO GIVE TEXTURE

BAR ENDS ARE 5/8" SQ.

**1584**

HEIGHT	40"	101.6 cm
WIDTH:	2 1/4" DIA AT BASKET	5.7 cm
THICK:	2 1/4" DIA AT BASKET	5.7 cm
WEIGHT:	1.6 lbs	0.7 kgs

THIS PIECE USES BASKET CAT. 1580

BASKET IS MADE FROM 4 PIECES OF 5/16" ALUMINUM

PICKET IS HAMMERED TO GIVE TEXTURE

BAR ENDS ARE 5/8" SQ.

**1585**

HEIGHT	40"	101.6 cm
WIDTH:	2 1/4" DIA AT BASKET	5.7 cm
THICK:	2 1/4" DIA AT BASKET	5.7 cm
WEIGHT:	1.7 lbs	4.32 kgs

BOTH ENDS OF THE PIECE ARE HAMMERED TO GIVE TEXTURE

BAR ENDS ARE 5/8" SQ.

**1587**

HEIGHT	40"	101.6 cm
WIDTH:	5/8"	1.6 cm
THICK:	5/8"	1.6 cm
WEIGHT:	1.5 lbs	3.81 kgs

BAR ENDS ARE 5/8" SQ.

**1588**

HEIGHT	40"	101.6 cm
WIDTH:	5/8"	1.6 cm
THICK:	5/8"	1.6 cm
WEIGHT:	1.5 lbs	3.81 kgs

FULL TWIST

BAR ENDS ARE 5/8" SQ.

**1589**

HEIGHT	40"	101.6 cm
WIDTH:	2 1/4" DIA AT BASKET	5.7 cm
THICK:	2 1/4" DIA AT BASKET	5.7 cm
WEIGHT:	1.7 lbs	0.8 kgs

Revision Date: 05/01/99

Toll Free (800) 527-1318

(972) 286-2368

Fax: (972) 557-4727



ALUMINUM CASTINGS

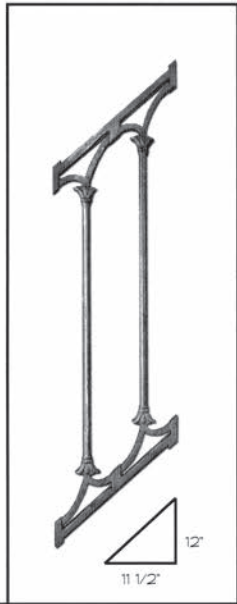

**937**  
 HEIGHT: 37" 93.98 cm  
 WIDTH: 8" 2.54 cm  
 THICK: 5/8" 0.625 cm  
 WEIGHT: 3.3 lbs 8.38 kgs

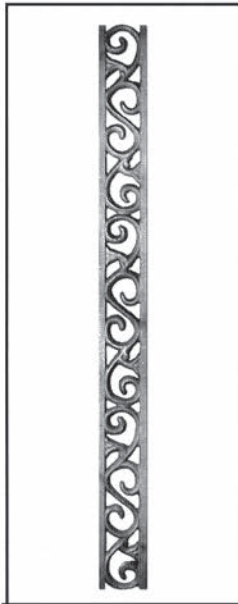

**938**  
 HEIGHT: 3 1/4" 8.26 cm  
 WIDTH: 41 1/4" 104.8 cm  
 THICK: 5/8" 0.63 cm  
 WEIGHT: 4.5 lbs 11.43 kgs



**482**  
 HEIGHT: 4 1/8" 10.48 cm  
 WIDTH: 25 3/4" 65.41 cm  
 THICK: 3/4" 1.91 cm  
 WEIGHT: 2.0 lbs 5.08 kgs

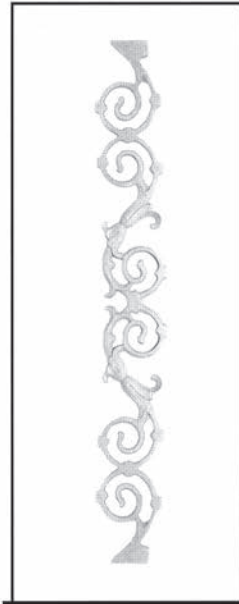

**483**  
 HEIGHT: 4 1/8" 10.48 cm  
 WIDTH: 31 7/8" 80.96 cm  
 THICK: 3/4" 1.91 cm  
 WEIGHT: 2.4 lbs 6.10 kgs

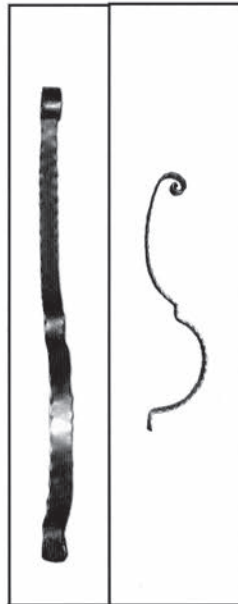

**2693**  
 HEIGHT: 39" 99.06 cm  
 WIDTH: 9 1/2" 24.13 cm  
 THICK: 2" 5.08 cm  
 WEIGHT: 2.8 lbs 7.11 kgs

Revision Date: 05/01/99



**1141**  
 HEIGHT: 40" 101.6 cm  
 DIA: 1 1/4" 3.18 cm  
 WEIGHT: 2.5 lbs 6.35 kgs

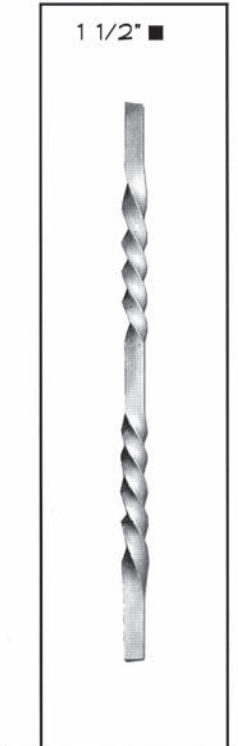

**9320**  
 HEIGHT: 40" 101.6 cm  
 WIDTH: 5/8" 1.6 cm  
 THICK: 5/8" 1.6 cm  
 WEIGHT: 1.5 lbs 3.81 kgs

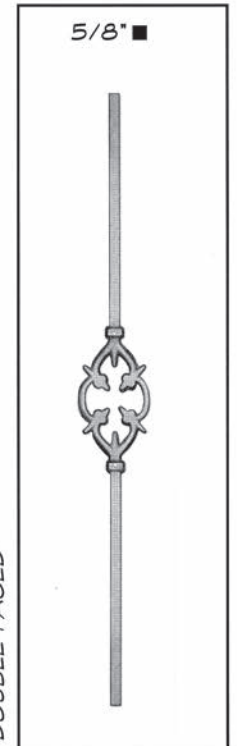

**158**  
 HEIGHT: 37 1/4" 94.62 cm  
 WIDTH: 4 1/2" 11.43 cm  
 THICK: 1 1/8" 2.54 cm  
 WEIGHT: 2.4 lbs 6.10 kgs

DOUBLE FACED



**159**  
 HEIGHT: 41 1/2" 105.4 cm  
 WIDTH: 4 3/8" 11.11 cm  
 THICK: 1 1/8" 2.86 cm  
 WEIGHT: 2.7 lbs 6.86 kgs

DOUBLE FACED

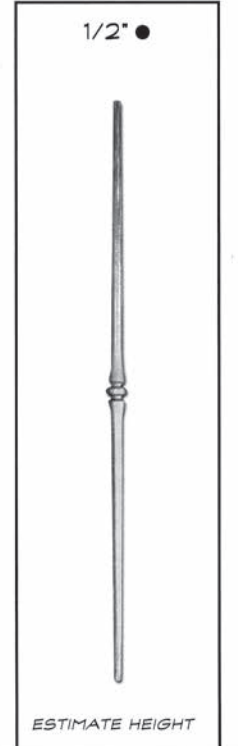

**161**  
 HEIGHT: 40" 101.6 cm  
 WIDTH: 2 1/4" 5.7 cm  
 THICK: 2 1/4" 5.7 cm  
 WEIGHT: 0.4 lbs 0.2 kgs

ESTIMATE HEIGHT



# ALLOY CASTING

Aluminum

Toll Free (800) 527-1318  
 (972) 286-2368  
 Fax (972) 557-4727

# BALLISTERS

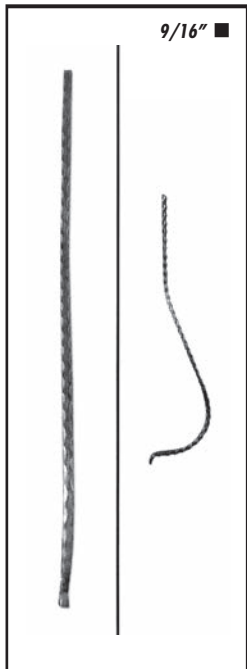

**2694**  
 HEIGHT 39"  
 WIDTH: 9"  
 THICK: 9/16"  
 WEIGHT: 1.2 lbs

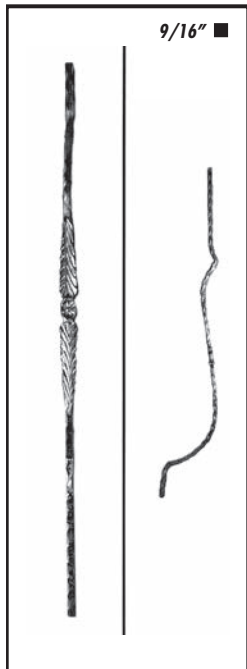

**2686**  
 HEIGHT 39 1/4"  
 WIDTH: 1 1/4"  
 THICK: 9/16"  
 WEIGHT: 1.2 lbs

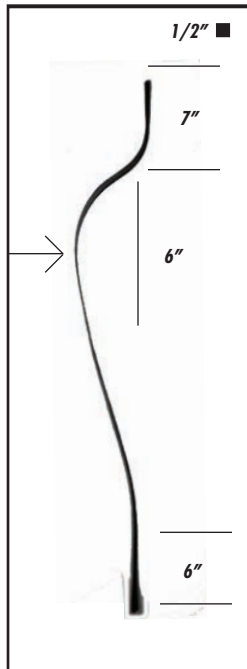

**1460**  
 HEIGHT 45 1/2"  
 WIDTH: 6 1/2"  
 THICK: 1/2"  
 WEIGHT: 1.2 lbs

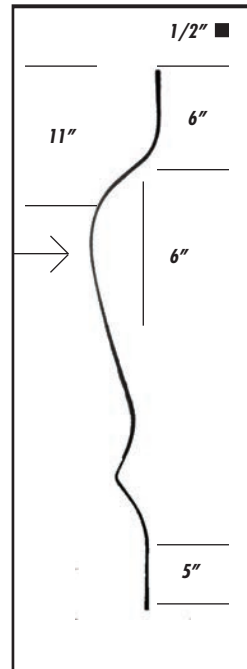

**1463**  
 HEIGHT 45"  
 WIDTH: 6"  
 THICK: 1/2"  
 WEIGHT: 1.1 lbs

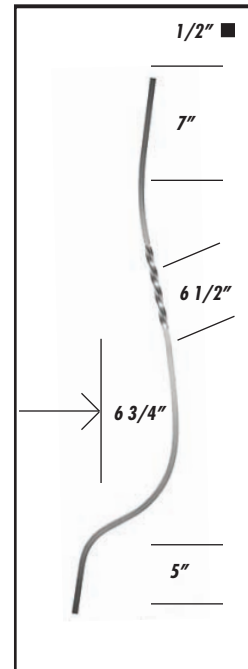

**1467**  
 HEIGHT 44 1/2"  
 WIDTH: 7"  
 THICK: 1/2"  
 WEIGHT: 1.1 lbs

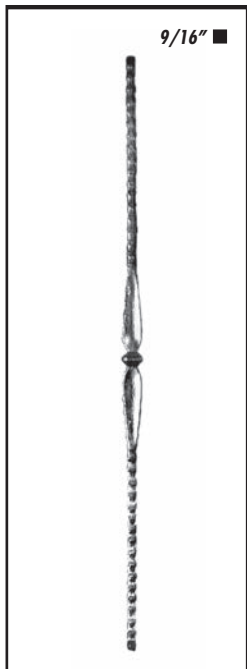

**1458**  
 HEIGHT 39"  
 WIDTH: 1 3/8"  
 THICK: 1 3/8"  
 WEIGHT: 1.3 lbs

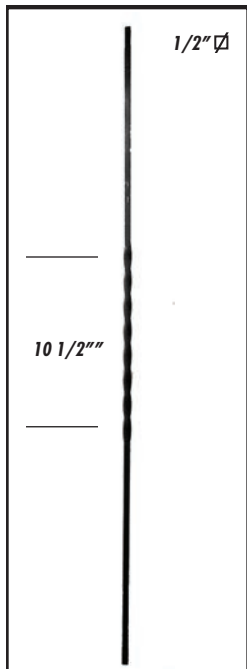

**1468**  
 HEIGHT 40"  
 WIDTH: 1/2"  
 THICK: 1/2"  
 WEIGHT: 1.0 lbs

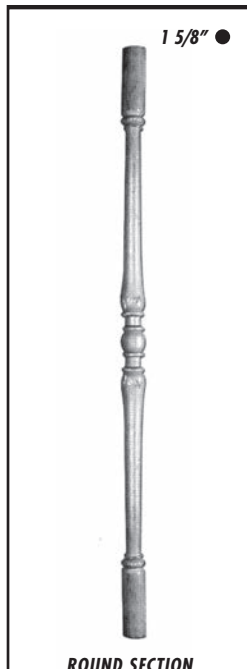

**9055**  
 HEIGHT 40 5/8"  
 WIDTH: 1 5/8"  
 THICK: 1 5/8"  
 WEIGHT: 5.2 lbs

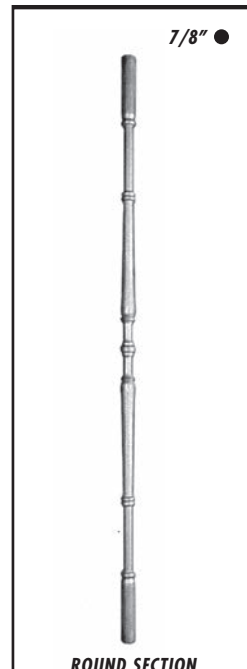

**9056**  
 HEIGHT 41"  
 WIDTH: 1" DIA  
 THICK: 1"  
 WEIGHT: 5.2 lbs

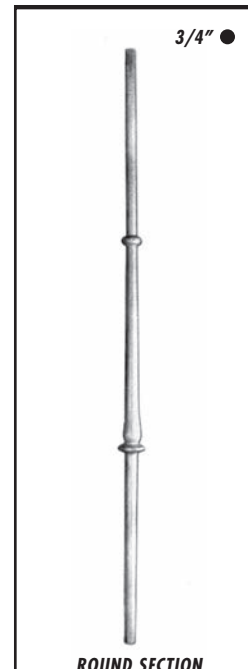

**9057**  
 HEIGHT 7"  
 WIDTH: 2 1/4"  
 THICK: 2 1/4"  
 WEIGHT: 0.4 lbs

Toll Free (800) 527-1318

(972) 286-2368

Fax: (972) 557-4727



ALUMINUM CASTINGS

2 PIECE POST TOP



2 PIECE POST BOTTOM



SET

**9571**

HEIGHT: 24.25"	61.6 cm
WIDTH: 4.63"	11.76 cm
THICK: 2.25"	5.72 cm
WEIGHT: 7.5 lbs	19.05 kgs

**9572**

HEIGHT: 23.5"	59.7 cm
WIDTH: 5.13"	13.03 cm
THICK: 2.5"	6.35 cm
WEIGHT: 11.0 lbs	27.9 kgs

2 PIECE POST



2 PIECE CROWN TOP FOR #9660



**9660**

HEIGHT: 29.88"	75.9 cm
WIDTH: 3.75"	9.53 cm
THICK: 1.75"	4.45 cm
WEIGHT: 9.4 lbs	23.88 kgs

**9661**

HEIGHT: 11.5"	29.21 cm
WIDTH: 5.63"	14.30 cm
THICK: 5.63"	14.30 cm
WEIGHT: 3.0 lbs	7.62 kgs

2 PIECE BOTTOM EXTENSION FOR #9660



**9662**

HEIGHT: 10"	25.4 cm
WIDTH: 3.75"	9.53 cm
THICK: 1.75"	4.45 cm
WEIGHT: 5.0 lbs	12.7 kgs

2 PIECE HOLLOW POST



NOT AVAILABLE

**9440**

HEIGHT: 32 1/2"	59.7 cm
WIDTH: 6" DIA	15.24 cm
THICK:	
WEIGHT: 17.0 lbs	43.18 kgs

SHOE FOR #9440

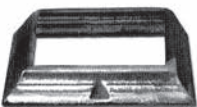

NOT AVAILABLE

**9435**

HEIGHT: 8.0"	20.32 cm
WIDTH: 8.0"	20.32 cm
THICK: 1 1/4"	3.18 cm
WEIGHT: 1.0 lbs est	2.54 kgs



SOLID

**160**

HEIGHT: 32 3/4"	83.19 cm
WIDTH: 2 7/8"	7.30 cm
THICK: 2 7/8"	7.30 cm
WEIGHT: 17 lbs	43.18 kgs

SET OR SINGLES

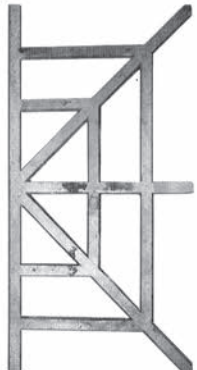
SAFE 4" SAFE

**7791**

HEIGHT: 30 1/2"	77.47 cm
WIDTH: 14 3/4"	37.47 cm
THICK: 1"	2.54 cm
WEIGHT: 10.6 lbs	26.9 kgs

**7797**

HEIGHT: 30 1/2"	77.47 cm
WIDTH: 15 1/2"	39.37 cm
THICK: 1"	2.54 cm
WEIGHT: 13.6 lbs	34.54 kgs

Revision Date: 05/01/99

DOUBLE FACED





# Alloy Casting





Toll Free (800) 527-1318

(972) 286-2368

Fax: (972) 557-4727





## ALUMINUM CASTINGS

### INDITAL ALUMINUM FORGINGS

				
<b>2685</b>	<b>2680</b>	<b>2684</b>	<b>2683</b>	<b>2687</b>
HEIGHT: 39 1/4" 99.70 cm WIDTH: 1 1/8" 2.86 cm THICK: 5/8" 0.63 cm WEIGHT: 1.1 lbs 2.79 kgs	HEIGHT: 47 3/4" 121.3 cm WIDTH: 1 3/8" 3.49 cm THICK: 7/8" 2.22 cm WEIGHT: 4.2 lbs 10.7 kgs	HEIGHT: 39 1/4" 99.70 cm WIDTH: 1 1/4" 3.18 cm THICK: 9/16" 1.44 cm WEIGHT: 1 lbs 2.54 kgs	HEIGHT: 39 1/4" 99.70 cm WIDTH: 5 1/4" 13.34 cm THICK: 1" 2.54 cm WEIGHT: 1.3 lbs 3.30 kgs	HEIGHT: 39 1/4" 99.70 cm WIDTH: 4 3/4" 12.07 cm THICK: 1 1/2" 3.81 cm WEIGHT: 1.5 lbs 3.81 kgs

ALL FORGINGS ON THIS PAGE ARE 9/16" ■

### INDITAL ALUMINUM FORGINGS

				
<b>2695</b>	<b>2696</b>	<b>2689</b>	<b>2688</b>	<b>2691</b>
HEIGHT: 40" 101.6 cm WIDTH: 7 1/2" 1.6 cm THICK: 5/8" 1.6 cm WEIGHT: 1.5 lbs 3.81 kgs	HEIGHT: 40" 101.6 cm WIDTH: 11 7/8" 5.7 cm THICK: 2 1/4" 5.7 cm WEIGHT: 1.5 lbs 0.7 kgs	HEIGHT: 39 1/4" 99.70 cm WIDTH: 8 1/4" 20.96 cm THICK: 1 1/2" 3.81 cm WEIGHT: 1.8 lbs 4.57 kgs	HEIGHT: 39 1/4" 99.70 cm WIDTH: 8 7/8" 22.54 cm THICK: 1" 2.54 cm WEIGHT: 1.9 lbs 4.83 kgs	HEIGHT: 39 1/4" 99.70 cm WIDTH: 9 1/4" 23.50 cm THICK: 1 1/2" 3.81 cm WEIGHT: 2.1 lbs 5.33 kgs

Revision Date: 05/01/99

Toll Free (800) 527-1318

(972) 286-2368

Fax: (972) 557-4727



ALUMINUM CASTINGS



**1346**

HEIGHT:	42 1/4"	107.3 cm
WIDTH:	6"	15.24 cm
THICK:	0.5"	1.27 cm
WEIGHT:	1.0 lbs	2.54 lbs

APPROXIMATE DIMENSIONS



**1143**

HEIGHT:	40"	101.6 cm
DIA:	3/4"	1.91 cm
WEIGHT:	1.0 est. lbs	2.54 kgs

NEW PRODUCTS

Revision Date: 05/01/99

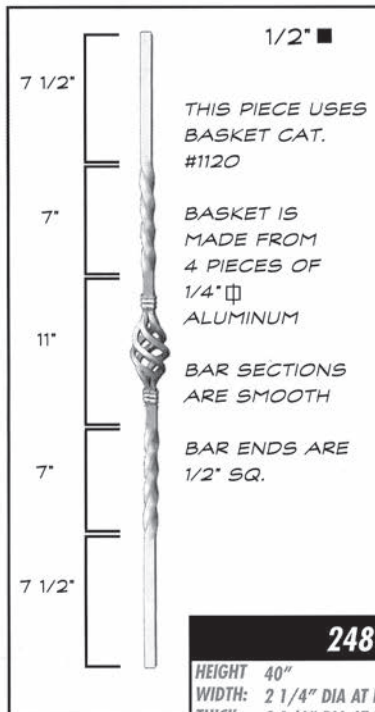

**2481**

HEIGHT	40"	101.6 cm
WIDTH:	2 1/4" DIA AT BASKET	5.7 cm
THICK:	2 1/4" DIA AT BASKET	5.7 cm
WEIGHT:	1.6 lbs	4.06 kgs

APPROXIMATE DIMENSIONS

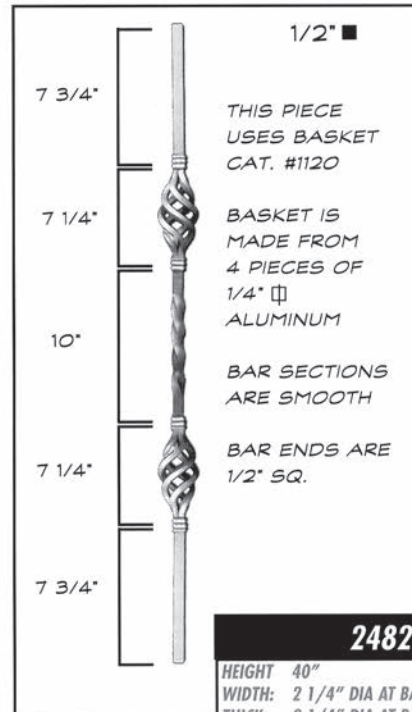

**2482**

HEIGHT	40"	101.6 cm
WIDTH:	2 1/4" DIA AT BASKET	5.7 cm
THICK:	2 1/4" DIA AT BASKET	5.7 cm
WEIGHT:	1.7 lbs	4.32 kgs

APPROXIMATE DIMENSIONS



**ALUMINUM CASTINGS**

**Call Toll Free : 800.527.1318 • Fax 972.557.4727**

**2004**  
**Spring Supplement-B**

**Visit [www.alloynet.com](http://www.alloynet.com)  
to view entire product catalog**

# Alloy Casting Supplement A - Index

PART	PG.	PART	PG.	PART	PG.	PART	PG.
#0082.....	131	#4387.....	124	#7776.....	126	#9307.....	130
#0091TX.....	138	#4399.....	127	#7806.....	132	#9319.....	125
#0091U.....	138	#4402.....	130	#7808.....	132	#9334.....	119
#0092.....	138	#4404.....	129	#7816.....	132	#9350.....	122,141
#0092TX.....	138	#4405.....	121	#7840.....	119	#9365.....	127
#0092U.....	138	#4420.....	120	#8025.....	141	#9366.....	127
#0142.....	127	#4428.....	120	#8042.....	141	#9382.....	123
#0144.....	127	#4432.....	120	#8045.....	141	#9386.....	135
#0145.....	127	#4434.....	131	#8060.....	127	#9410.....	135
#0146.....	127	#4446.....	122	#8061.....	141	#9437.....	133,141
#0148.....	127	#4452.....	131	#8160.....	132	#9513.....	141
#0154.....	125	#4453.....	120	#8164.....	132	#9527.....	123
#0156.....	125	#4457.....	130	#8165.....	132	#9528.....	123
#0162.....	124	#4460.....	133	#8166.....	132	#9530.....	132
#0163.....	122	#4465.....	133	#8218.....	128	#9549.....	134
#0166.....	122	#4466.....	133	#8219.....	128	#9570.....	141
#0168.....	123	#4470.....	130	#8226.....	128	#9583.....	120
#0169.....	124	#4473.....	131	#8234.....	128	#9584.....	120
#0178.....	124	#4474.....	120	#8235.....	128	#9605.....	127
#0181.....	122,131	#4494.....	133	#8241.....	128	#9609.....	141
#0562.....	141	#4701.....	133	#8243.....	128	#9655.....	132
#0591.....	141	#4705.....	125	#8245.....	129	#9675.....	126
#0719.....	125	#4707.....	124	#8255.....	129	#9677.....	120
#0721.....	130	#4709.....	125	#8272.....	128	#9688.....	120
#0722.....	130	#4710.....	125	#8273.....	128	#9713.....	120
#0723.....	130	#4712.....	124	#8281.....	128	#9716.....	120
#0724.....	130	#4714.....	121	#8282.....	128	#9733.....	141
#0770.....	122	#4716.....	121	#8283.....	129	#9734.....	130
#0866.....	121	#4718.....	120	#8284.....	129	#9756.....	123
#0906.....	135	#4719.....	133	#8291.....	128	#9775.....	119
#0939.....	133	#4721.....	133	#8294.....	129	#AL535-0140.....	140
#0997.....	122,141	#4722.....	134	#8298.....	128	#AL535-0143.....	140
#0998.....	141	#4726.....	121	#8299.....	129	#AL535-0164.....	140
#1244.....	126	#4731.....	121	#8340.....	126	#AL535-0165.....	140
#1245.....	126	#4739.....	120	#8344.....	126	#AL535-0634.....	140
#1246.....	126	#4762W/4768.....	131	#8345.....	126	#AL535-1030.....	140
#1248.....	126	#4768W/4762.....	131	#8346.....	126	#AL535-1035.....	140
#1443.....	127	#4787W/4806.....	131	#8380.....	127	#AL535-3301.....	140
#1800.....	121	#4788.....	131	#8384.....	127	#AL535-3302.....	140
#1803.....	141	#4806/4787.....	131	#8385.....	127	#AL535-3303.....	140
#1804.....	121	#7010.....	119	#8386.....	127	#AL535-3304.....	140
#1852.....	141	#7022.....	119	#8406.....	133	#AL535-3306.....	140
#1861F.....	138	#7140.....	119	#8442.....	130	#AL535-3315.....	140
#1861U.....	138	#7240.....	119	#8445.....	130	#AL535-3325.....	140
#1902.....	124	#7327.....	118	#8844.....	123	#AL535-3410.....	140
#1922.....	119	#7371.....	118	#8846.....	123	#AL535-3415.....	140
#2088.....	141	#7372.....	118	#8847.....	123	#AL535-3420.....	140
#2161.....	122	#7373.....	118	#8848.....	123	#AL535-3425.....	140
#3331.....	125	#7374.....	118	#8849.....	123	#AL535-3430.....	140
#3332.....	125	#7375.....	118	#9030.....	122	#AL535-3440.....	140
#3333.....	125	#7376.....	118	#9032.....	135	#AL535-7134.....	140
#3430.....	141	#7377.....	118	#9080.....	124	#AL535-7137.....	140
#3440.....	141	#7378.....	118	#9125.....	130	#AL535-7140.....	140
#3441.....	141	#7379.....	118	#9245.....	132	#AL535-7144.....	140
#3460.....	141	#7440.....	119	#9256.....	141	#AL535-7152.....	140
#3530.....	141	#7510.....	119	#9258.....	141	#AL535-7157.....	140
#3531.....	141	#7540.....	119	#9291.....	132	#AL535-8215.....	140
#3735.....	131	#7550.....	119	#9299.....	124	#AL535-8223.....	140
#3738.....	131	#7640.....	119	#9300.....	122,141	#AL535-8264.....	140
#3741.....	131	#7774.....	124	#9304.....	127		
#3750.....	133,141	#7775.....	126	#9305.....	127		



# Aluminum Castings

**Catalog # 106B - Supplement B - Spring 2004**



Product #930 and #939 in a deck rail

## CONTENTS

Allomet.....	140	Palm, Bananas.....	133
Ballisters.....	124,125	Panel Scrolls.....	121
Big Tex.....	135	Plaques.....	138,139
Circles.....	118-120	Posts.....	122,123
Collars-Round.....	129	Sign And Mailbox.....	141
Collars-Square.....	126	Spears-Slip Over.....	128
Fab Cad/Auto Cad.....	136	Stars/Western.....	130
Gate Designs.....	137	Sea Shells.....	132
Horses.....	131	Spears-Drive In.....	129
Maps.....	142	Sales Tax-Texas.....	142

**OVER  
250 NEW!  
PRODUCTS!**

 **Alloy Casting**  
ALUMINUM CASTINGS

**Call Toll Free : 800.527.1318**

**Fax : 972.557.4727**



**NEW**  
DOUBLE FACE



SAFE 4" SAFE

DONUT  
5/8" DIA SECTION

**7327**

HEIGHT 3 7/8" DIA  
 WIDTH: 5/8"  
 THICK: 5/8"  
 WEIGHT: 0.3 lbs

**NEW**  
DOUBLE FACE



SAFE 4" SAFE

CENTER RIDGE

**7371**

HEIGHT 3 7/8" DIA  
 WIDTH: 9/16"  
 THICK: 3/4"  
 WEIGHT: 0.3 lbs

**NEW**  
DOUBLE FACE



SAFE 4" SAFE

**7372**

HEIGHT 3 7/8" DIA"  
 WIDTH: 3/4"  
 THICK: 3/4"  
 WEIGHT: 0.3 lbs

**NEW**  
DOUBLE FACE



SAFE 4" SAFE

BAMBOO

**7373**

HEIGHT 3 7/8" DIA"  
 WIDTH: 3/4"  
 THICK: 3/4"  
 WEIGHT: 0.3 lbs

**NEW**  
DOUBLE FACE



SAFE 4" SAFE

REED AND RIBBON

**7374**

HEIGHT 3 7/8" DIA  
 WIDTH: 7/8"  
 THICK: 5/8"  
 WEIGHT: 0.3 lbs

**NEW**  
DOUBLE FACE



SAFE 4" SAFE

HAMMERED EDGES

**7375**

HEIGHT 3 7/8" DIA  
 WIDTH: 5/8"  
 THICK: 3/4"  
 WEIGHT: 0.3 lbs

**NEW**  
DOUBLE FACE



SAFE 4" SAFE

TWISTED ROPE

**7376**

HEIGHT 3 7/8" DIA  
 WIDTH: 5/8"  
 THICK: 1/2"  
 WEIGHT: 0.3 lbs

**NEW**  
DOUBLE FACE



SAFE 4" SAFE

DIAMOND

**7377**

HEIGHT 3 7/8" DIA  
 WIDTH: 5/8"  
 THICK: 1/2"  
 WEIGHT: 0.3 lbs

**NEW**  
DOUBLE FACE



SAFE 4" SAFE

RIVETS

**7378**

HEIGHT 3 7/8" DIA  
 WIDTH: 5/8"  
 THICK: 3/4"  
 WEIGHT: 0.3 lbs

**NEW**  
DOUBLE FACE



SAFE 4" SAFE

RIDGES

**7379**

HEIGHT 3 7/8" DIA  
 WIDTH: 5/8"  
 THICK: 1/2"  
 WEIGHT: 0.3 lbs



# ALLOY CASTING

Aluminum

Toll Free (800) 527-1318

(972) 286-2368

Fax (972) 557-4727

# OVALS/CIRCLES

**NEW**  
FLAT BACK

**7140**  
HEIGHT 4 DIA"  
WIDTH: 4 DIA"  
THICK: 1/2"  
WEIGHT: .25 lbs

**7240**  
HEIGHT 3 7/8"  
WIDTH: 3 7/8"  
THICK: 1/2"  
WEIGHT: 0.2 lbs

**7440**  
HEIGHT 4" DIA  
WIDTH: 4" DIA  
THICK: 1/2"  
WEIGHT: .25 lbs

**7640**  
HEIGHT 3 7/8"  
WIDTH: 3 7/8"  
THICK: 1/2"  
WEIGHT: 0.2 lbs

**7840**  
HEIGHT 3 7/8" DIA  
WIDTH: 3 7/8" DIA  
THICK: 1/2"  
WEIGHT: 0.4 lbs

SINGLE FACE

**7940**  
HEIGHT 3 7/8"  
WIDTH: 3 7/8"  
THICK: 1/2"  
WEIGHT: 0.2 lbs

DOUBLE FACE

**9977**  
HEIGHT 4"  
WIDTH: 3 1/2"  
THICK: 1/2"  
WEIGHT: 0.25 lbs

**NEW**  
FLAT BACK

1" FACE

**7022/7010**  
HEIGHT 22" DIA 10" DIA  
WIDTH: 22" DIA 10" DIA  
THICK: 1/2" 1/2"  
WEIGHT: 3.1 lbs 1.4 lbs

**NEW**  
DOUBLE FACE 3 1/2"  $\varnothing$

1/2" FACE

**9775**  
HEIGHT 3 1/2" DIA  
WIDTH: 3 1/2" DIA  
THICK: 3/4"  
WEIGHT: 0.3 lbs

**NEW**  
DOUBLE FACE 3 1/2"  $\varnothing$

3/4" FACE

**9334**  
HEIGHT 3 1/2" DIA  
WIDTH: 3 1/2" DIA  
THICK: 3/4"  
WEIGHT: 0.4 lbs

**NEW**  
DOUBLE FACE

1/2" FACE BY 1" DEEP

**1922**  
HEIGHT 33"  
WIDTH: 12 1/4"  
THICK: 1"  
WEIGHT: 4.1 lbs

**NEW**  
SINGLE FACE

**7510**  
HEIGHT 10"  
WIDTH: 3 3/4"  
THICK: 1/2"  
WEIGHT: .60 lbs

**NEW**  
SINGLE FACE

**7540**  
HEIGHT 3 13/16"  
WIDTH: 2 3/4"  
THICK: 1/2"  
WEIGHT: .25 lbs

**NEW**  
SINGLE FACE

**7550**  
HEIGHT 5 1/8"  
WIDTH: 3 13/16"  
THICK: 1/2"  
WEIGHT: 0.3 lbs

CIRCLES

Toll Free (800) 527-1318  
 (972) 286-2368  
 Fax (972) 557-4727

ALLOY CASTING

Aluminum



**NEW**

DOUBLE FACE

**4420**

HEIGHT 8 3/8" DIA  
 WIDTH: 8 3/8" DIA  
 THICK: 3/4"  
 WEIGHT: 1.0 lbs

**NEW**

DOUBLE FACE

**4474**

HEIGHT 8" DIA  
 WIDTH: 8" DIA  
 THICK: 3/4"  
 WEIGHT: 1.2 lbs

**NEW**

DOUBLE FACE

9 1/4" DIA - TIP TO TIP

**4453**

HEIGHT 7 3/8" DIA  
 WIDTH: 7 3/8" DIA  
 THICK: 5/8"  
 WEIGHT: 0.9 lbs

**NEW**

DOUBLE FACE

**4739**

HEIGHT 7 5/8" DIA  
 WIDTH: 7 5/8" DIA  
 THICK: 9/16"  
 WEIGHT: 0.9 lbs

**NEW**

DOUBLE FACE

RING 3/8" FACE

**9713**

HEIGHT 13" DIA  
 WIDTH: 13" DIA  
 THICK: 1 1/4"  
 WEIGHT: 7.7 lbs

**NEW**

FLAT BACK

RING 5/8" FACE

**9716**

HEIGHT 15" DIA  
 WIDTH: 15" DIA  
 THICK: 5/8"  
 WEIGHT: 5.0 lbs

**NEW**

DOUBLE FACE

**4718**

HEIGHT 12 7/8"  
 WIDTH: 6 3/8"  
 THICK: 3/8"  
 WEIGHT: 1.0 lbs

**NEW**

DOUBLE FACE

**4432**

HEIGHT 15 1/2"  
 WIDTH: 9"  
 THICK: 1/2"  
 WEIGHT: 1.8 lbs

**NEW**

FLAT BACK

RING 1/2" FACE

**9688**

HEIGHT 18" DIA  
 WIDTH: 18" DIA  
 THICK: 3/4"  
 WEIGHT: 7.5 lbs

**NEW**

DOUBLE FACE

**9677**

HEIGHT 17 3/4"  
 WIDTH: 10 3/4"  
 THICK: 7/8"  
 WEIGHT: 4.4 lbs

**NEW**

FLAT BACK

**9583**

HEIGHT 3 5/8"  
 WIDTH: 32 1/2"  
 THICK: 1/2"  
 WEIGHT: 2.5 lbs

**NEW**

FLAT BACK

**4428**

3 1/2" ID

HEIGHT 4 3/4"  
 WIDTH: 29 3/8"  
 THICK: 1"  
 WEIGHT: 3.5 lbs

**NEW**

FLAT BACK

**9584**

HEIGHT 4 7/8"  
 WIDTH: 31 3/4"  
 THICK: 1/2"  
 WEIGHT: 2.4 lbs





# ALLOY CASTING

Aluminum

Toll Free (800) 527-1318

(972) 286-2368

Fax (972) 557-4727

## PANEL SCROLLS

**NEW**  
DOUBLE FACE



**866**  
HEIGHT 15 1/8"  
WIDTH: 5 7/8"  
THICK: 1"  
WEIGHT: 4.5 lbs

**NEW**  
DOUBLE FACE



**4731**  
HEIGHT 23 3/4"  
WIDTH: 8"  
THICK: 3/8"  
WEIGHT: 1.2 lbs

**NEW**  
DOUBLE FACE



**1804**  
HEIGHT 5 3/8"  
WIDTH: 23 5/8"  
THICK: 3/4"  
WEIGHT: 2.1 lbs

**NEW**  
DOUBLE FACE



RING 1/4" WIDE

**1800**  
HEIGHT 40 1/4"  
WIDTH: 9 1/8"  
THICK: 3/4"  
WEIGHT: 5 lbs

**NEW**  
DOUBLE FACE



**4714**  
HEIGHT 27 3/4"  
WIDTH: 8"  
THICK: 3/8"  
WEIGHT: 1.4 lbs

**NEW**  
SINGLE FACE



**4405**  
HEIGHT 27 1/2"  
WIDTH: 6 3/4"  
THICK: 1/2"  
WEIGHT: 1.3 lbs

**NEW**  
DOUBLE FACE



**4716**  
HEIGHT 29 1/2"  
WIDTH: 8"  
THICK: 1/2"  
WEIGHT: 1.6 lbs

**NEW**  
DOUBLE FACE



**4726**  
HEIGHT 23"  
WIDTH: 7 7/8"  
THICK: 1/2"  
WEIGHT: 1.4 lbs

FLAT BACK



**3788**  
HEIGHT 22 DIA"  
WIDTH: 0  
THICK: 3/4"  
WEIGHT: 9 lbs



SCROLL 3/4" ROUND 4" OK

**941**  
HEIGHT 27 5/8"  
WIDTH: 10 3/4"  
THICK: 7/8"  
WEIGHT: 5.5 lbs

POSTS / BALLISTERS

Toll Free (800) 527-1318  
 (972) 286-2368  
 Fax (972) 557-4727

ALLOY CASTING

Aluminum



**NEW**

DOUBLE FACE 3" Ø

2 PIECE SPLIT POST TO WELD

**9030**

HEIGHT 25 1/4"  
 WIDTH: 6 7/8" DIA  
 THICK: 6 7/8" DIA  
 WEIGHT: 4.1 lbs

**NEW**

DOUBLE FACE 2 3/8" Ø

SINGLE PIECE POST

**997**

HEIGHT 28 1/2"  
 WIDTH: 6 1/2" DIA  
 THICK: 6 1/2" DIA  
 WEIGHT: 17.5 lbs

**NEW**

DOUBLE FACE

OPEN

2 PIECE HOLLOW POST  
 8" OCT BASE

**181**

HEIGHT 38"  
 WIDTH: 1/4"  
 THICK: 1/4"  
 WEIGHT: 14.0 lbs

**NEW**

DOUBLE FACE 3" Ø

SINGLE PIECE POST

SEE PAGE #105 FOR MATCHING COLLAR #35

**9300**

HEIGHT 24"  
 WIDTH: 17 1/4" DIA  
 THICK: 1/4" WALL  
 WEIGHT: 9.0 lbs

**NEW**

DOUBLE FACE 3" Ø

2 PIECE SPLIT POST TO WELD

**9350**

HEIGHT 24"  
 WIDTH: 17 1/4" DIA  
 THICK: 1/4" WALL  
 WEIGHT: 4.3 lbs

**NEW**

DOUBLE FACE

**4446**

HEIGHT 28 3/8"  
 WIDTH: 3 5/8"  
 THICK: 3/4"  
 WEIGHT: 1.8 lbs

**NEW**

DOUBLE FACE

**166**

HEIGHT 32 1/4"  
 WIDTH: 3 1/2"  
 THICK: 1"  
 WEIGHT: 2.8 lbs

**NEW**

DOUBLE FACE

**770**

HEIGHT 41"  
 WIDTH: 9 1/2"  
 THICK: 1 1/2"  
 WEIGHT: 5.0 lbs

**NEW**

DOUBLE FACE

ENDS  
 1/2" Ø

REPLACES #161

**2161**

HEIGHT 40"  
 WIDTH: 1 3/8" DIA  
 THICK: 1 3/8" DIA  
 WEIGHT: 1.7 lbs

**NEW**

DOUBLE FACE

ROUND SHAPE  
 35 1/2" OVAL, SEAT TO SEAT

**163**

HEIGHT 35 1/2"  
 WIDTH: 2" DIA  
 THICK: 2" DIA  
 WEIGHT: 2.7 lbs



# ALLOY CASTING

Aluminum

Toll Free (800) 527-1318

(972) 286-2368

Fax (972) 557-4727

## POSTS/COLLARS

**NEW**



TOP- 2 7/16" DIA, BOTTOM 3" DIA

**168**

HEIGHT 40 1/4"  
WIDTH: 3 1/2" DIA  
THICK: 3 1/2" DIA  
WEIGHT: 22.0 lbs

**NEW**

TOP 3/4" DIA



BASE 2" DIA

**9382**

HEIGHT 35 1/4"  
WIDTH: XXX  
THICK: XXX  
WEIGHT: 5.90 lbs

**NEW**



1 3/8" OCTAGONAL SECTION

**9756**

HEIGHT 40 1/4"  
WIDTH: 2 5/8" DIA  
THICK: 2 5/8" DIA  
WEIGHT: 6.10 lbs

**NEW**

4" Ø



2 PC POST, 4 1/2" ID HOLE

**8849**

HEIGHT 36"  
WIDTH: 10 3/4"  
THICK: 10 3/4"  
WEIGHT: 44.0 lbs

**NEW**

4" Ø



2 PC CAPITAL, 4 1/2" ID

**8844**

HEIGHT 6 1/2"  
WIDTH: 8 3/4" RD  
THICK: 8 3/4" RD  
WEIGHT: 9.0"

**NEW**

4" Ø



2 PIECE RING COLLAR 4 1/2" ID

**8846**

HEIGHT 1 5/8"  
WIDTH: 6 1/8" DIA  
THICK: 3/4"  
WEIGHT: 1.0 lbs

**NEW**



OPENING 1 3/4" DIA, 2 PC TOP

**9527**

HEIGHT 26 1/4"  
WIDTH: 3 5/8"  
THICK: 3 1/4"  
WEIGHT: 6.50 lbs

SET

**NEW**



TOP OPENING 1 3/4" DIA, 2 PC BOTTOM

**9528**

HEIGHT 24 1/4"  
WIDTH: 3 3/4" SQ  
THICK: 3 3/4"  
WEIGHT: 8.0 lbs

**NEW**

4" Ø



2 PC POST BASE, 4 1/2" ID

**8848**

HEIGHT 8"  
WIDTH: 6 3/4" DIA  
THICK: 6 3/4" DIA  
WEIGHT: 8.50"

**NEW**

4" Ø



2 PC POST BASE, 4 1/2" ID

**8847**

HEIGHT 8"  
WIDTH: 8 1/2" RD  
THICK: 8 1/2" RD  
WEIGHT: 8.50 lbs

# BALLISTERS

Toll Free (800) 527-1318  
 (972) 286-2368  
 Fax (972) 557-4727

## ALLOY CASTING

Aluminum



**NEW**  
DOUBLE FACE

**ROUND SECTION**

**7774**

HEIGHT: 20"  
 WIDTH: 3" DIA  
 THICK: 3" DIA  
 WEIGHT: 3.80 lbs

**NEW**  
DOUBLE FACE

**ROUND**

**9080**

HEIGHT: 13 1/2"  
 WIDTH: 4 3/4" DIA  
 THICK: 4 3/4" DIA  
 WEIGHT: 10.50 lbs

**NEW**  
DOUBLE FACE

**4387**

HEIGHT: 28 1/8"  
 WIDTH: 4 5/8"  
 THICK: 1"  
 WEIGHT: 2.70 lbs

**NEW**  
DOUBLE FACE

**SAFE 4" SAFE**

**1902**

HEIGHT: 35 1/2"  
 WIDTH: 9 1/4"  
 THICK: 2"  
 WEIGHT: 7.80 lbs

**NEW**  
DOUBLE FACE

**162**

HEIGHT: 36"  
 WIDTH: 6"  
 THICK: 9/16"  
 WEIGHT: 7.40 lbs

**NEW**  
DOUBLE FACE

**COLLARS  
1 1/2" DIA**

**178**

HEIGHT: 40 1/4"  
 WIDTH: 1 1/4"  
 THICK: 1 1/4"  
 WEIGHT: 4.90 lbs

**NEW**  
DOUBLE FACE

**15" FLUTED L**

**9299**

HEIGHT: 41"  
 WIDTH: 1 1/2"  
 THICK: 1 1/2"  
 WEIGHT: 7.0 lbs

**NEW**  
DOUBLE FACE

**BAR 1/2 "SQ END,  
PINS 1/4" DIA**

**4707**

HEIGHT: 28 1/2"  
 WIDTH: 4 1/4"  
 THICK: 7/8"  
 WEIGHT: 0.80 lbs

**NEW**  
DOUBLE FACE

**ENDS 1/4" X 1/2"**

**4712**

HEIGHT: 27 1/4"  
 WIDTH: 4 1/4"  
 THICK: 7/8"  
 WEIGHT: 0.80 lbs

**NEW**  
DOUBLE FACE

**COLLARS  
1 1/2" DIA**

**169**

HEIGHT: 3 1/2"  
 WIDTH: 2 3/4"  
 THICK: 3/4"  
 WEIGHT: 3.10 lbs





# ALLOY CASTING

Aluminum

Toll Free (800) 527-1318

(972) 286-2368

Fax (972) 557-4727

## BALLISTERS / ROPE



CENTER COLLAR 2" DIA ENDS  
NOMINAL 7/8" DIA

**150**

HEIGHT 39 1/2"  
WIDTH: 2"  
THICK: 2"  
WEIGHT: 3.6 lbs.



DOUBLE FACE

OUTSIDE COLLARS 18 1/2"  
APART MATCHES 1952; ENDS  
ARE NOMINAL 1" DIA

**1951**

HEIGHT 40 1/2"  
WIDTH: 1 7/8" DIA  
THICK: 2"  
WEIGHT: 3.5 lbs.



DOUBLE FACE

OUTSIDE COLLARS 18 1/2"  
APART MATCHES 1951; ENDS  
ARE NOMINAL 1" DIA

**1952**

HEIGHT 40 1/2"  
WIDTH: 1 7/8" DIA  
THICK: 2"  
WEIGHT: 4.2 lbs.

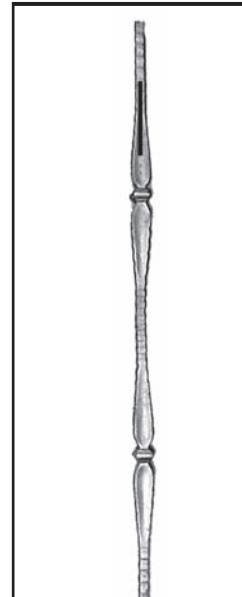

ENDS 5/8" SQUARE

**1457**

HEIGHT 38 3/4"  
WIDTH: 1 1/4"  
THICK: 1 1/2"  
WEIGHT: 1.5 lbs

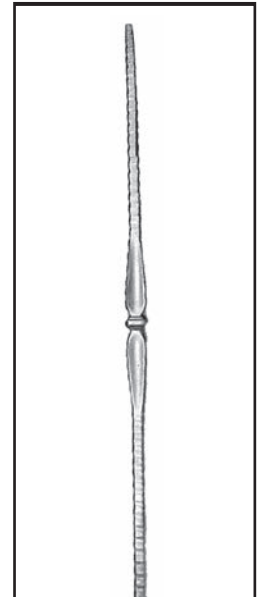

ENDS NOMINAL 1/2" SQUARE

**1458**

HEIGHT 39"  
WIDTH: 1 1/4"  
THICK: 1 1/2"  
WEIGHT: 1.3 lbs



NEW

NOT TO SCALE

FACETED BALL 1 1/4" H BY 1  
1/4" DIA ENDS 5/8" SQ

**1771**

HEIGHT 39 1/4"  
WIDTH: 1 1/4"  
THICK: 1 1/4"  
WEIGHT: 1.5 lbs

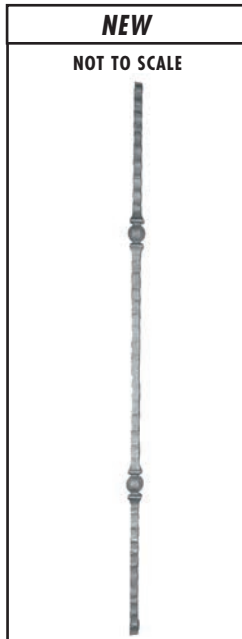

NEW

NOT TO SCALE

FACETED BALL 1 1/4" H BY 1  
1/4" DIA ENDS 5/8" SQ

**1772**

HEIGHT 40 1/2"  
WIDTH: 1 1/4"  
THICK: 1 1/4"  
WEIGHT: 1.7 lbs



NEW

NOT TO SCALE

BAR ENDS 1" SQ BALL DIA  
NOMINAL 2"

**1770**

HEIGHT 40"  
WIDTH: 2"  
THICK: 2"  
WEIGHT: 4.0 lbs

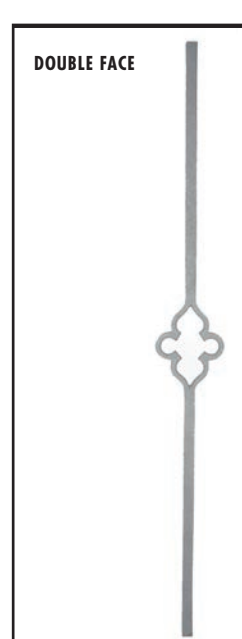

DOUBLE FACE

3/4" SQ. NOMINAL PICKET

**2531**

HEIGHT 42"  
WIDTH: 4 3/4"  
THICK: 3/4"  
WEIGHT: 2.6 lbs

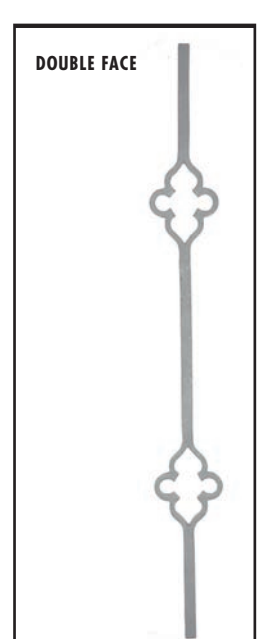

DOUBLE FACE

3/4" SQ. NOMINAL PICKET

**2532**

HEIGHT 42"  
WIDTH: 4 3/4"  
THICK: 3/4"  
WEIGHT: 2.6 lbs

Toll Free (800) 527-1318  
 (972) 286-2368  
 Fax (972) 557-4727

**ALLOY CASTING**

Aluminum



**NEW**  
 NOT TO SCALE  
 DOUBLE FACE

ENDS 1/2" DIA

**2161**

HEIGHT 40"  
 WIDTH: 1 3/8" DIA  
 THICK:  
 WEIGHT: 1.9 lbs.

**NEW**  
 NOT TO SCALE  
 DOUBLE FACE

ENDS 1/2" DIA

**2162**

HEIGHT 40 3/4"  
 WIDTH: 1 3/8" DIA  
 THICK:  
 WEIGHT: 1.9 lbs.

**NEW**  
 NOT TO SCALE

CENTER BALL 1 1/2" DIA END  
 1" DIA

**9208**

HEIGHT 40 1/4"  
 WIDTH: 1 1/2"  
 THICK: 1 1/2"  
 WEIGHT: 3.8 lbs

**NEW**  
 NOT TO SCALE  
 DOUBLE FACE

ENDS 1 1/8"W BY 1 1/4" OVAL

**1887**

HEIGHT 40 3/4"  
 WIDTH: 7/8" DIA  
 THICK: 7/8" DIA  
 WEIGHT: 1.9 lbs

DOUBLE FACE

ENDS 1" ROUND

**167**

HEIGHT 31 1/2"  
 WIDTH: 2 1/4"  
 THICK: 1 3/8"  
 WEIGHT: 2.9 lbs

**NEW**  
 NOT TO SCALE

CENTER COLLAR 1 1/4" DIA ENDS  
 9/16" DIA

**2191**

HEIGHT 44"  
 WIDTH: 1 1/4"  
 THICK: 1 1/4"  
 WEIGHT: 1.2 lbs

**NEW**  
 NOT TO SCALE

CENTER COLLAR 1 1/4" DIA ENDS  
 9/16" DIA

**2192**

HEIGHT 44"  
 WIDTH: 1 1/4"  
 THICK: 1 1/4"  
 WEIGHT: 1.2 lbs

**NEW**  
 NOT TO SCALE

ENDS 9/16" DIA

**2193**

HEIGHT 40"  
 WIDTH: 2 5/8"  
 THICK: 1 1/4"  
 WEIGHT: 1.2 lbs

**NEW**  
 NOT TO SCALE  
 DOUBLE FACE

DIAMOND SHAPED

**2241**

HEIGHT 40 1/4"  
 WIDTH: 9"  
 THICK: 1"  
 WEIGHT: 1.5 lbs

**NEW**  
 NOT TO SCALE  
 DOUBLE FACE

DIAMOND SHAPED CTRS  
 16 3/8" APART

**2242**

HEIGHT 40"  
 WIDTH: 9"  
 THICK: 1"  
 WEIGHT: 1.9 lbs



# ALLOY CASTING

Aluminum

Toll Free (800) 527-1318

(972) 286-2368

Fax (972) 557-4727

## BALLISTERS / ROPE

**NEW**

DOUBLE FACE  
SHORT NOTE HEIGHT

ENDS 1/2" DIA

**4705**

HEIGHT: 28 5/8"  
WIDTH: 1 1/8" DIA  
THICK: 1 1/8" DIA  
WEIGHT: 0.9 lbs.

**NEW**

DOUBLE FACE  
SHORT NOTE HEIGHT

ENDS 1/2" DIA

**4710**

HEIGHT: 29 1/8"  
WIDTH: 2" DIA  
THICK: 2" DIA  
WEIGHT: 1.2 lbs.

**NEW**

DOUBLE FACE  
SHORT NOTE HEIGHT

ENDS 1/2" DIA

**4709**

HEIGHT: 28 1/8"  
WIDTH: 1 3/8"  
THICK: 1 3/8"  
WEIGHT: 0.9 lbs

**NEW**

DOUBLE FACE

ENDS 1/2" SQUARE

**154**

HEIGHT: 41 1/2"  
WIDTH: 2 1/4"  
THICK: 2 1/4"  
WEIGHT: 2.7 lbs

**NEW**

DOUBLE FACE

**156**

HEIGHT: 28 3/8"  
WIDTH: 7 3/4"  
THICK: 3/4"  
WEIGHT: 1.7 lbs

**NEW**

DOUBLE FACE 3/4" ■

**3331**

HEIGHT: 41"  
WIDTH: 2"  
THICK: 2"  
WEIGHT: 2.6 lbs

**NEW**

DOUBLE FACE 3/4" ■

TOP AND BOTTOM COLLARS  
9 1/2" FROM END,

**3332**

HEIGHT: 41"  
WIDTH: 2"  
THICK: 2"  
WEIGHT: 3.2 lbs

**NEW**

DOUBLE FACE 3/4" ■

TOP AND BOTTOM COLLARS  
9 1/2" FROM END,

**3333**

HEIGHT: 41"  
WIDTH: 2"  
THICK: 2"  
WEIGHT: 3.5 lbs

**NEW**

FLAT BACK

2" REPEAT

SEE PRODUCT #1141 AND 1143 FOR FULL ROUND FORGED ROPE

**719**

HEIGHT: 32"  
WIDTH: 2"  
THICK: 1"  
WEIGHT: 3.6 lbs

**NEW**

SINGLE FACE

1 1/2" REPEAT

**9319**

HEIGHT: 41"  
WIDTH: 2 1/2"  
THICK: 7/8"  
WEIGHT: 5.4 lbs

**TRIFECTA GROUP - CAST ON COLLARS**

# COLLARS - SQUARE

Toll Free (800) 527-1318  
 (972) 286-2368  
 Fax (972) 557-4727

**ALLOY CASTING**

Aluminum



**NEW**  
 DOUBLE FACE

5/8"  $\square$

3/4"  $\square$

1/2"  $\square$

1"  $\square$

**8344**  
 HEIGHT 1 3/8"  
 WIDTH: 1 5/8" DIA  
 THICK:  
 WEIGHT: 0.1 lbs

**8345**  
 HEIGHT 1 1/4"  
 WIDTH: 1 1/2" DIA  
 THICK:  
 WEIGHT: 0.1 lbs

**8346/OLD 8050**  
 HEIGHT 1 3/4"  
 WIDTH: 2" DIA  
 THICK:  
 WEIGHT: 0.3 lbs

**8340/INQUIRY**

**NEW**  
 DOUBLE FACE 5/8"  $\square$

**SQUARE SECTION**

**7776**  
 HEIGHT 1 3/8"  
 WIDTH: 1 1/2"  
 THICK: 1 1/2"  
 WEIGHT: 0.2 lbs

**NEW**  
 DOUBLE FACE 5/8"  $\square$

**ROUND SECTION**

**7775**  
 HEIGHT 2 5/8" DIA  
 WIDTH: 2 5/8" DIA  
 THICK:  
 WEIGHT: 0.5 lbs

**NEW**  
 DOUBLE FACE 3/4"  $\square$

**ROUND SECTION**

**9675**  
 HEIGHT 2 5/8"  
 WIDTH: 1 7/8" DIA  
 THICK: 1 7/8" DIA  
 WEIGHT: 0.4 lbs

**NEW**  
 DOUBLE FACE

5/8"  $\square$

3/4"  $\square$

1/2"  $\square$

1"  $\square$

**1244/INQUIRY**

**1245/INQUIRY**

**1246**  
 HEIGHT 2 3/4"  
 WIDTH: 2 1/2" DIA  
 THICK: 2 1/2" DIA  
 WEIGHT: 0.6 lbs est.

**1248/INQUIRY**





# ALLOY CASTING

Aluminum

Toll Free (800) 527-1318

(972) 286-2368

Fax (972) 557-4727

# COLLARS-ROUND

**NEW**

DOUBLE FACE  $5/8"$   $\varnothing$



$3/4"$   $\varnothing$

BALL COLLARS FOR ROUND

$1/2"$   $\varnothing$   $1"$   $\varnothing$

**8384/INQUIRY**

HEIGHT 1 3/8"  
WIDTH: 1 5/8" DIA  
THICK: 1 5/8" DIA  
WEIGHT: 0.1 lbs

**8385**

HEIGHT 1 1/4"  
WIDTH: 1 1/2" DIA  
THICK: 1 1/2" DIA  
WEIGHT: .10 lbs

**8386**

HEIGHT 1 7/8"  
WIDTH: 2" DIA  
THICK: 2" DIA  
WEIGHT: .35 lbs

**8380/INQUIRY**

**NEW**

DOUBLE FACE  $3/4"$   $\varnothing$



**1443**

HEIGHT 3"  
WIDTH: 2" DIA  
THICK: 2" DIA  
WEIGHT: 0.4 lbs

**NEW**

DOUBLE FACE  $1/2"$   $\varnothing$



2" DIA BASE

**8060**

HEIGHT 5 1/2"  
WIDTH: 2 3/4 RD  
THICK: 2" DIA  
WEIGHT: 1.5 lbs

**NEW**

DOUBLE FACE  $5/8"$   $\varnothing$



$3/4"$   $\varnothing$

$1/2"$   $\varnothing$   $1"$   $\varnothing$

**142**

HEIGHT 1 5/8"  
WIDTH: 1 3/8" DIA  
THICK: 1 3/8" DIA  
WEIGHT: 0.1 lbs

**145/INQUIRY**

**146**

HEIGHT 2 3/4"  
WIDTH: 2 1/2" DIA  
THICK: 2 1/2" DIA  
WEIGHT: 0.6 lbs

**148/INQUIRY**

**NEW**

DOUBLE FACE  $5/8"$   $\varnothing$



**4399**

HEIGHT 3 1/4"  
WIDTH: 2 3/8" DIA  
THICK: 2 3/8" DIA  
WEIGHT: 0.6 lbs

**NEW**

DOUBLE FACE  $5/8"$   $\varnothing$



5/8" DIA HOLE

**144**

HEIGHT 4 3/4"  
WIDTH: 1 1/2" DIA  
THICK: 1" DIA ENDS  
WEIGHT: 0.3 lbs

**NEW**

DOUBLE FACE  $2"$   $\varnothing$



2 PIECE

**9365**

HEIGHT 1/2"  
WIDTH: 2 7/8" DIA  
THICK: 1/2"  
WEIGHT: 0.2 lbs

**NEW**

DOUBLE FACE  $6"$   $\varnothing$



2 PIECE SET MALE AND FEMALE

**9605**

HEIGHT 2"  
WIDTH: 7 1/2" DIA  
THICK: 1/2"  
WEIGHT: 4.2 lbs

**NEW**

DOUBLE FACE  $4"$   $\varnothing$



BOTTOM LIP OPEN 4" DIA, 4 PIECE SET

**9304/9305**

HEIGHT 10 1/2"  
WIDTH: 6 5/8" DIA  
THICK: 1/2"  
WEIGHT: 9 lbs

**NEW**

DOUBLE FACE  $6"$   $\varnothing$



2 PIECE

**9366**

HEIGHT 2"  
WIDTH: 7 1/4" DIA"  
THICK: 1/2"  
WEIGHT: 1.8 lbs

SPEARS - SLIP OVER

Toll Free (800) 527-1318  
 (972) 286-2368  
 Fax (972) 557-4727

ALLOY CASTING

Aluminum



**NEW**  
 1/2" ∅



**8235**  
 HEIGHT 5 1/8"  
 WIDTH: 3 3/8"  
 THICK: 7/8"  
 WEIGHT: 0.2 lbs

**NEW**  
 1/2" ∅



CIRCLE 2 1/8" DIA  
**8218**  
 HEIGHT 4 1/2"  
 WIDTH: 2 7/8"  
 THICK: 1"  
 WEIGHT: 0.3 lbs.

**NEW**  
 1/2" ∅



**8219**  
 HEIGHT 5 1/2"  
 WIDTH: 3 1/2"  
 THICK: 1"  
 WEIGHT: 0.3 lbs

**NEW**  
 1/2" ∅



**8273**  
 HEIGHT 4 3/4"  
 WIDTH: 3 1/8"  
 THICK: 1 3/8"  
 WEIGHT: 0.3 lbs

**NEW**  
 1/2" ∅



**8272**  
 HEIGHT 5 5/8"  
 WIDTH: 2 3/4"  
 THICK: 1 1/4"  
 WEIGHT: 0.5 lbs

**NEW**  
 3/4" ∅



**8281**  
 HEIGHT 5"  
 WIDTH: 1 7/8"  
 THICK: 1 7/8"  
 WEIGHT: 1.10 lbs

**NEW**  
 3/4" ∅



**8243**  
 HEIGHT 7"  
 WIDTH: 2"  
 THICK: 2"  
 WEIGHT: 0.7 lbs

**NEW**  
 3/4" ∅



MATCHES #9298 ON PAGE 99  
**8298**  
 HEIGHT 7 1/2"  
 WIDTH: 3 1/2"  
 THICK: 1 3/8"  
 WEIGHT: 0.5 lbs

**NEW**  
 3/4" ∅



**8234**  
 HEIGHT 5 3/8"  
 WIDTH: 2 1/4"  
 THICK: 1 3/8"  
 WEIGHT: 1.10 lbs

**NEW**  
 1" ∅



**8241**  
 HEIGHT 8"  
 WIDTH: 2 1/8"  
 THICK: 2 1/2"  
 WEIGHT: 1.10 lbs

**NEW**  
 1" ∅



**8282**  
 HEIGHT 9 1/8"  
 WIDTH: 5"  
 THICK: 1 5/8"  
 WEIGHT: 1.10 lbs

**NEW**  
 1 1/4" ∅



**8226**  
 HEIGHT 6"  
 WIDTH: 2 1/8"  
 THICK: 2 1/8"  
 WEIGHT: 0.7 lbs

**NEW**  
 2" ∅



**8291**  
 HEIGHT 10 1/8"  
 WIDTH: 3 1/2"  
 THICK: 3 1/2"  
 WEIGHT: 3.2 lbs



# ALLOY CASTING

Aluminum

Toll Free (800) 527-1318

(972) 286-2368

Fax (972) 557-4727

SPEARS

SLIP OVER TYPE

**NEW**

DOUBLE FACE 5/8"  $\nabla$



IN DEVELOPMENT

**8285**

HEIGHT 5 1/4  
WIDTH: 3 3/8  
THICK: 7/8  
WEIGHT: 0.20

**NEW**

DOUBLE FACE 3/4"  $\nabla$



**8265**

HEIGHT 5 7/8  
WIDTH: 3 5/8  
THICK: 1 1/4  
WEIGHT: 0.40

**NEW**

DOUBLE FACE 5/8"  $\nabla$



**8258**

HEIGHT 6  
WIDTH: 4  
THICK: 1 1/4  
WEIGHT: 0.25

**NEW**

DOUBLE FACE 3/4"  $\nabla$

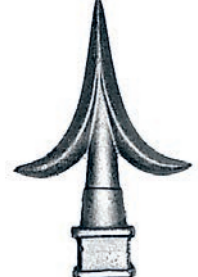

**8228**

HEIGHT 6  
WIDTH: 4  
THICK: 1 1/4  
WEIGHT: 0.30

**NEW**

DOUBLE FACE 3/4"  $\nabla$



**8274**

HEIGHT 4  
WIDTH: 1 1/2  
THICK: 1 3/8 DIA  
WEIGHT: 0.15

**NEW**

DOUBLE FACE 1/2"  $\nabla$



**8216**

HEIGHT 4  
WIDTH: 1  
THICK: 1  
WEIGHT: 0.10

**NEW**

DOUBLE FACE 1"  $\nabla$



**8296**

HEIGHT 5 3/4  
WIDTH: 1 3/4  
THICK: 1 3/4  
WEIGHT: 0.60

**NEW**

DOUBLE FACE 3/4"  $\nabla$



**8233**

HEIGHT 6 1/2  
WIDTH: 3 5/8  
THICK: 2 1/8  
WEIGHT: 0.70

**NEW**

DOUBLE FACE 3/4"  $\nabla$



**8288**

HEIGHT 7 1/4  
WIDTH: 2 1/2  
THICK: 1 7/8  
WEIGHT: 0.70

**NEW**

DOUBLE FACE 1"  $\nabla$



**9489**

HEIGHT 8  
WIDTH: 4  
THICK: 3  
WEIGHT: 2.00

**NEW**

DOUBLE FACE 1/2"  $\nabla$



**8236**

HEIGHT 6  
WIDTH: 2 1/8  
THICK: 1 3/4  
WEIGHT: 0.35



**NEW**

DOUBLE FACE 3/4" ■

STUB 1/2 SQ X 1 LONG

**8295**

HEIGHT 6 7/8"  
 WIDTH: 3 1/2"  
 THICK: 1 7/8"  
 WEIGHT: 0.40 lbs

**NEW**

DOUBLE FACE 5/8" ■

STUB 1/2 SQ X 1 LONG

**8275**

HEIGHT 5"  
 WIDTH: 1"  
 THICK: 1"  
 WEIGHT: 0.20 lbs

**NEW**

DOUBLE FACE 3/4" ■

STUB 5/8 SQ X 1 LONG

**8276**

HEIGHT 5"  
 WIDTH: 1"  
 THICK: 1"  
 WEIGHT: 0.20 lbs

**NEW**

DOUBLE FACE 1" ■

STUB 3/4 SQ X 7/8 LONG  
 FOR .063 WALL TUBING  
 H - 4 3/8 OVER SEAT

**8247**

HEIGHT 5 1/2"  
 WIDTH: 1 1/8"  
 THICK: 1 1/8"  
 WEIGHT: 0.20 lbs

**NEW**

DOUBLE FACE 1" ■

STUB 7/8 SQ X 7/8 LONG  
 FOR .125 WALL TUBING  
 H - 4 3/8 OVER SEAT

**8248**

HEIGHT 5 1/2"  
 WIDTH: 1 1/8"  
 THICK: 1 1/8"  
 WEIGHT: 0.20 lbs

**NEW**

DOUBLE FACE 3/4" ■

STUB 5/8 X 5/8 X 7/8 LONG

**8293**

HEIGHT 5 1/4"  
 WIDTH: 2 1/4"  
 THICK: 1"  
 WEIGHT: 0.20 lbs





# ALLOY CASTING

Aluminum

Toll Free (800) 527-1318

(972) 286-2368

Fax (972) 557-4727

## SPEARS - DRIVE IN & FLAT BASE

**NEW**

3/4" ■



STUB 5/8" SQUARE BY 7/8" LONG

**8245**

HEIGHT 4 3/4"  
WIDTH: 3"  
THICK: 1"  
WEIGHT: 0.2 lbs

**NEW**

3/4" ■



STUB 5/8" SQUARE BY 5/8" LONG

**8227**

HEIGHT 3 5/8"  
WIDTH: 1 1/2"  
THICK: 1 1/8"  
WEIGHT: 0.1 lbs

**NEW**

3/4" ■



STUB 5/8" SQUARE BY 7/8" LONG

**8283**

HEIGHT 5 3/4"  
WIDTH: 2"  
THICK: 1"  
WEIGHT: 0.15 lbs

**NEW**

1" ■



STUB 3/4" SQUARE BY 1" LONG

**8284**

HEIGHT 7"  
WIDTH: 1"  
THICK: 1"  
WEIGHT: 0.3 lbs

**NEW**

1" ■



STUB 7/8" SQUARE BY 1" LONG

**8255**

HEIGHT 6"  
WIDTH: 3/8"  
THICK: 1"  
WEIGHT: 0.35 lbs

**NEW**

DOUBLE FACE



FLAT OVAL BASE 2" W BY 1 1/2" DEEP

**8294**

HEIGHT 6 1/2"  
WIDTH: 3 1/4"  
THICK: 1 1/2"  
WEIGHT: 0.8 lbs

**NEW**

DOUBLE FACE



FLAT BASE 2 1/4" W BY 1 3/8" DEEP

**8299**

HEIGHT 10 5/8"  
WIDTH: 6 1/8"  
THICK: 1 3/8"  
WEIGHT: 2.0 lbs

**NEW**

DOUBLE FACE



STUB 1/2" CIRCLE BY 5/8" LENGTH

**4404**

HEIGHT 4 1/4"  
WIDTH: 3"  
THICK: 7/8"  
WEIGHT: 0.1 lbs

**NEW**

DOUBLE FACE



STUB 3/4" SQ BY 3/4" L

**8259**

HEIGHT 6 1/4"  
WIDTH: 1 1/2"  
THICK: 1 1/8"  
WEIGHT: 0.35 lbs

**NEW**

DOUBLE FACE



STUB 3/4" SQ BY 3/4" L

**8244**

HEIGHT 6 1/4"  
WIDTH: 1 1/2"  
THICK: 1 1/8"  
WEIGHT: 0.35 lbs



**NEW**  
 FLAT BACK

HOLE DIAMETERS VARY 1/4" - 5/8"

**721**  
 HEIGHT 2 7/8"  
 WIDTH: 2 3/4"  
 THICK: 1/4"  
 WEIGHT: 0.1 lbs

**722**  
 HEIGHT 4 1/4"  
 WIDTH: 4 1/4"  
 THICK: 3/8"  
 WEIGHT: 0.2 lbs

**723**  
 HEIGHT 6 3/4"  
 WIDTH: 6 3/4"  
 THICK: 1/2"  
 WEIGHT: 0.4 lbs

**724**  
 HEIGHT 8"  
 WIDTH: 8"  
 THICK: 1/2"  
 WEIGHT: 0.6 lbs

**NEW**  
 HOLLOW BACK WITH CENTER  
 BOSS 1" DIA

**4470**  
 HEIGHT 11 5/8"  
 WIDTH: 11 5/8"  
 THICK: 7/8"  
 WEIGHT: 1.5 lbs

**NEW**  
 DOUBLE FACE

**9125**  
 HEIGHT 10 1/8"  
 WIDTH: 10 3/4"  
 THICK: 3/4"  
 WEIGHT: 1.5 lbs

**NEW**  
 DOUBLE FACE

RING 1/4" WIDE

**9734**  
 HEIGHT 3 1/2"  
 WIDTH: 3 1/2"  
 THICK: 3/4"  
 WEIGHT: 0.4 lbs

**NEW**  
 DOUBLE FACE

**8442**  
 HEIGHT 5 5/8"  
 WIDTH: 5 5/8"  
 THICK: 1"  
 WEIGHT: 1 lbs

**NEW**  
 DOUBLE FACE

**8445**  
 HEIGHT 5 5/8"  
 WIDTH: 5 5/8"  
 THICK: 1"  
 WEIGHT: 1.6 lbs

**NEW**  
 HOLLOW BACK

**9307**  
 HEIGHT 4 1/2"  
 WIDTH: 4 1/2"  
 THICK: 3/4"  
 WEIGHT: 0.2 lbs

**NEW**  
 DOUBLE FACE

**4402**  
 HEIGHT 12 1/4"  
 WIDTH: 27 3/4"  
 THICK: 1 1/4"  
 WEIGHT: 5.2 lbs

**NEW**  
 FLAT BACK

**4457**  
 HEIGHT 7 3/4"  
 WIDTH: 17 1/4"  
 THICK: 5/8"  
 WEIGHT: 1.2 lbs



# ALLOY CASTING

Aluminum

Toll Free (800) 527-1318

(972) 286-2368

Fax (972) 557-4727

# HORSES

**NEW**

DOUBLE FACE

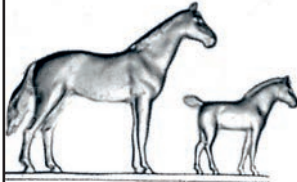

**4434**

HEIGHT 8 3/4"  
WIDTH: 14 1/4"  
THICK: 5/8"  
WEIGHT: 1.9 lbs

**NEW**

8" OCTAGONAL  
BASE



OPENING  
BOTH SIDES  
1 3/4" X 3 1/2"

2 PIECE HOLLOW POST

**181**

HEIGHT 38"  
WIDTH:  
THICK:  
WEIGHT: 14 lbs



HORSES HEAD, 2 PIECES REQUIRED.  
FITS OVER A 2" OUTSIDE DIAMETER TUBE.  
PIECES MAY BE WELDED TOGETHER.

**82**

HEIGHT 11"  
WIDTH: 8 1/2"  
THICK: 3"  
WEIGHT: 1.6 lbs

**NEW**

DOUBLE FACE



TOP  
2 1/2" X 2 3/4"

BOTTOM  
2 1/2" SQUARE

1 PIECE

**4473**

HEIGHT 17"  
WIDTH: 7 3/4"  
THICK: 2 1/2"  
WEIGHT: 14 lbs

**NEW**

DOUBLE FACE



2 PIECE HOLLOW

**4762/4768**

HEIGHT 9"  
WIDTH: 10"  
THICK: 2 3/8"  
WEIGHT: 1.4 lbs

**NEW**

DOUBLE FACE



2 PIECE HOLLOW

**4787/4806**

HEIGHT 11 1/4"  
WIDTH: 12"  
THICK: 2 5/8"  
WEIGHT: 3.1 lbs

**NEW**

DOUBLE FACE

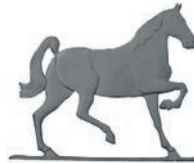

**4452**

HEIGHT 10 3/8"  
WIDTH: 12 1/2"  
THICK: 7/8"  
WEIGHT: 1.5 lbs

**NEW**

HOLLOW BACK



**4788**

HEIGHT 10 1/2"  
WIDTH: 16 1/4"  
THICK: 3/4"  
WEIGHT: 1.2 lbs

FLAT BACK



**3738**

HEIGHT 9 1/2"  
WIDTH: 12"  
THICK: 1/2"  
WEIGHT: 1.6 lbs

FLAT BACK



**3735**

HEIGHT 13 1/4"  
WIDTH: 16 3/4"  
THICK: 3/4"  
WEIGHT: 4 lbs

**NEW**

FLAT BACK



**3741**

HEIGHT 18 1/2"  
WIDTH: 38"  
THICK: 1/2"  
WEIGHT: 12 lbs



**NEW**  
 DOUBLE FACE 3/4"

**7806**  
 HEIGHT 40"  
 WIDTH: 3/4" DIA  
 THICK: 3/4" DIA  
 WEIGHT: 2.0 lbs

**NEW**

SEE BAMBOO RING #7373

**BAMBOO**  
**TYPICAL DETAIL**

**NEW**  
 DOUBLE FACE 1"

**7808**  
 HEIGHT 40"  
 WIDTH: 1" DIA  
 THICK: 1" DIA  
 WEIGHT: 3.2 lbs

**NEW**  
 DOUBLE FACE 2"

**7816**  
 HEIGHT 40"  
 WIDTH: 2" DIA  
 THICK: 2" DIA  
 WEIGHT: 12.0 lbs

**NEW**  
 DOUBLE FACE

RING 1/4" FACE

**9655**  
 HEIGHT 6" DIA  
 WIDTH: 6" DIA  
 THICK: 1"  
 WEIGHT: 1.8 lbs

**NEW**  
 DOUBLE FACE

BASE 4" WIDE

**9291**  
 HEIGHT 6"  
 WIDTH: 6 1/2"  
 THICK: 1/2"  
 WEIGHT: 1.0 lbs

**NEW**  
 FLAT BACK

**8165**  
 HEIGHT 4"  
 WIDTH: 4"  
 THICK:  
 WEIGHT:

**NEW**  
 FLAT BACK 4"

**8166/INQUIRY**  
**IN DEVELOPMENT**

FLAT BACK 3 5/8" DIA

**9245**  
 HEIGHT 3 5/8"  
 WIDTH: 3 7/8"  
 THICK: 5/8"  
 WEIGHT: 0.5 lbs

**NEW**  
 FLAT BACK 15" DIA

SAME DESIGN

**9530**  
 HEIGHT 15 1/4"  
 WIDTH: 16 1/4"  
 THICK: 1 1/2"  
 WEIGHT: 21.0 lbs

**NEW**  
 FLAT BACK 4"

SAME DESIGN

**8164/INQUIRY**  
**IN DEVELOPMENT**

**NEW**  
 FLAT BACK 10"

SAME DESIGN

**8160/INQUIRY**  
**IN DEVELOPMENT**





# ALLOY CASTING

Aluminum

Toll Free (800) 527-1318

(972) 286-2368

Fax (972) 557-4727

## PALMS/ BANANAS

**NEW**  
DOUBLE FACE

**939**  
HEIGHT 29 1/8"  
WIDTH: 13 1/2"  
THICK: 3/4"  
WEIGHT: 9.2 lbs

**NEW**  
DOUBLE FACE

**3750**  
HEIGHT 23 1/2"  
WIDTH: 13 1/2"  
THICK: 1 1/2"  
WEIGHT: 7.3 lbs

**NEW**  
DOUBLE FACE

**4721**  
HEIGHT 15 3/4"  
WIDTH: 6"  
THICK: 3/8"  
WEIGHT: 0.8 lbs

**NEW**  
HOLLOW BACK

**4494**  
HEIGHT 14 1/2"  
WIDTH: 6 1/4"  
THICK: 5/8"  
WEIGHT: 0.7 lbs

**NEW**  
DOUBLE FACE

**9437**  
HEIGHT 14"  
WIDTH: 9"  
THICK: 3/4"  
WEIGHT: 1.3 lbs

**NEW**  
DOUBLE FACE

**4701**  
HEIGHT 15 1/2"  
WIDTH: 14 3/4"  
THICK: 1"  
WEIGHT: 2 lbs

**NEW**  
DOUBLE FACE

**8406**  
HEIGHT 5 5/8"  
WIDTH: 5 5/8"  
THICK: 1/2"  
WEIGHT: 0.7 lbs

**NEW**  
DOUBLE FACE

**4465**  
HEIGHT 14"  
WIDTH: 9"  
THICK: 3/4"  
WEIGHT: 1.8 lbs

**NEW**  
DOUBLE FACE

6 1/4" REPEAT  
**4719**  
HEIGHT 24"  
WIDTH: 8 1/2"  
THICK: 1/2"  
WEIGHT: 2.5 lbs

**NEW**  
DOUBLE FACE

**4460**  
HEIGHT 30"  
WIDTH: 8 3/4"  
THICK: 5/8"  
WEIGHT: 3.1 lbs

**NEW**  
HOLLOW BACK

**4466**  
HEIGHT 14"  
WIDTH: 13"  
THICK: 1"  
WEIGHT: 2 lbs

Toll Free (800) 527-1318  
(972) 286-2368  
Fax (972) 557-4727

## ALLOY CASTING

Aluminum



**NEW**

DOUBLE FACE



**4722**

HEIGHT 24 1/2"  
WIDTH: 6 3/4"  
THICK: 3/4"  
WEIGHT: 2.7 lbs

**NEW**

DOUBLE FACE



RING 5/8" FACE

**9549**

HEIGHT 8 1/4" DIA  
WIDTH: 8 1/4" DIA  
THICK: 1/2"  
WEIGHT: 1.4 lbs



# ALLOY CASTING

Aluminum

Toll Free (800) 527-1318

(972) 286-2368

Fax (972) 557-4727

# BIG TEX PANELS

**DOUBLE FACE**

**906**

HEIGHT 32"  
WIDTH: 19"  
THICK: 1 1/2"  
WEIGHT: 23 lbs

**DOUBLE FACE**

5/8" SQUARE SECTION

**9032**

HEIGHT 32"  
WIDTH: 21"  
THICK: 5/8"  
WEIGHT: 11 lbs

**DOUBLE FACE**

5/8" SQUARE SECTION

**9386**

HEIGHT 32"  
WIDTH: 23"  
THICK: 3/4"  
WEIGHT: 17 lbs

**DOUBLE FACE**

NOMINAL SECTION  
3/4" WIDE X 1" THICK

**9410**

HEIGHT 33"  
WIDTH: 25"  
THICK: 1.5"  
WEIGHT: 22 lbs

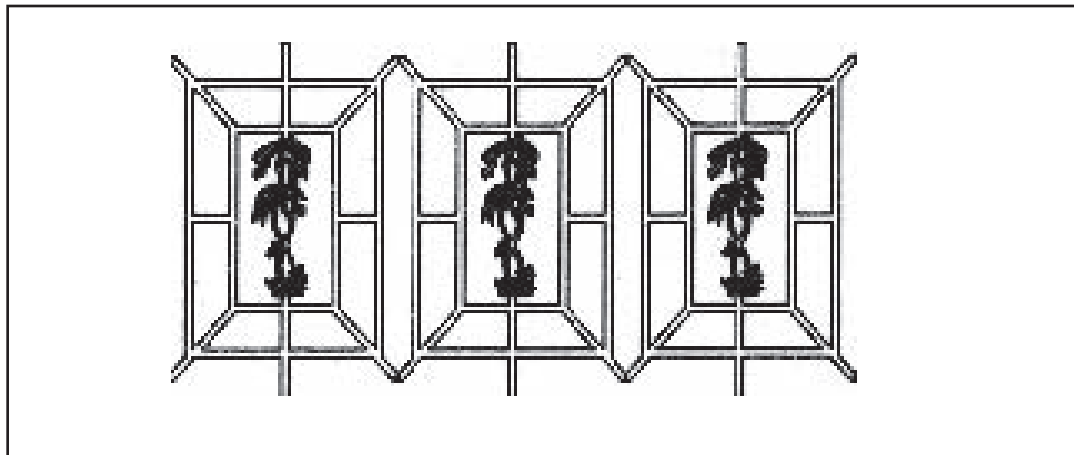

**INQUIRY**

Custom design possibilities. **BIG TEX** Panels Approximately 24" by 34".  
Exact size depends upon cross section and layout.

**INQUIRY**

**INQUIRY**

**INQUIRY**

See page 114 for 2 piece split design possibilities #7791 and #7797



# 300 FREE Images

FREE UPGRADES

CD contains:  
 Tiff, AutoCad dwg, and dxf  
 formats for "universal" use.

Call Toll Free 800-527-1318  
 Fax 972-557-4727

**Alloy Casting**  
 ALUMINUM CASTINGS  
 3900 S. Peachtree Road • Mesquite, TX 75180-2724  
[www.alloynet.com](http://www.alloynet.com)

## Automatic Rail and Gate drawing programs

QTY	DESIGNATION	LEN	ENJ
1	1/2" SQ TUBE X 6'-2"	90 DEG. CLT	90 DEG. CUT
1	1/2" SQ TUBE X 3'-2" 1/2"	90 DEG. CLT	84 DEG. CUT
1	1/2" SQ TUBE X 0' 8" 5/8"	90 DEG. CLT	90 DEG. CUT
1	1/2" SQ TUBE ROLLED - SEE DETAIL		
1	1/2" SQ TUBE X 2' 0" 15/16"	60 DEG. CLT	45 DEG. CUT
1	1/2" SQ TUBE X 6' 5/8"	45 DEG. CLT	45 DEG. CUT
1	1/2" SQ TUBE X 9' 5/8"	45 DEG. CLT	60 DEG. CUT
1	1/2" SQ TUBE ROLLED - SEE DETAIL		
1	5/8" SQ TUBE X 4' 11" 7/8"	90 DEG. CLT	67 DEG. CUT
1	5/8" SQ TUBE X 5'-0" 7/8"	90 DEG. CLT	75 DEG. CUT
1	5/8" SQ TUBE X 5'-1" 25/16"	90 DEG. CLT	76 DEG. CUT
1	5/8" SQ TUBE X 5'-2" 7/8"	90 DEG. CLT	81 DEG. CUT
1	5/8" SQ TUBE X 5'-7" 3/8"	90 DEG. CLT	83 DEG. CUT
1	5/8" SQ TUBE X 5'-7" 5/8"	90 DEG. CLT	84 DEG. CUT
3	5/8" SQ TUBE X 6'-0" 1/8"	90 DEG. CLT	90 DEG. CUT
2	5/8" SQ TUBE X 6'-11" 3/4"	90 DEG. CLT	90 DEG. CUT
1	5/8" SQ TUBE X 7'-0" 1/8"	90 DEG. CLT	80 DEG. CUT
1	5/8" SQ TUBE X 7'-1" 3/4"	90 DEG. CLT	84 DEG. CUT
1	5/8" SQ TUBE X 7'-4" 3/8"	90 DEG. CLT	88 DEG. CUT

- Compatible with Alloy Casting designs
- Develops all dimensions and cut lists.
- Only basic computer knowledge required

For more information visit us at  
[www.fabcad.com](http://www.fabcad.com)  
 or call :  
 1-800-255-9032  
 FABCAD.USA





# ALLOY CASTING

Aluminum

Toll Free (800) 527-1318

(972) 286-2368

Fax (972) 557-4727

# GATE DESIGNS

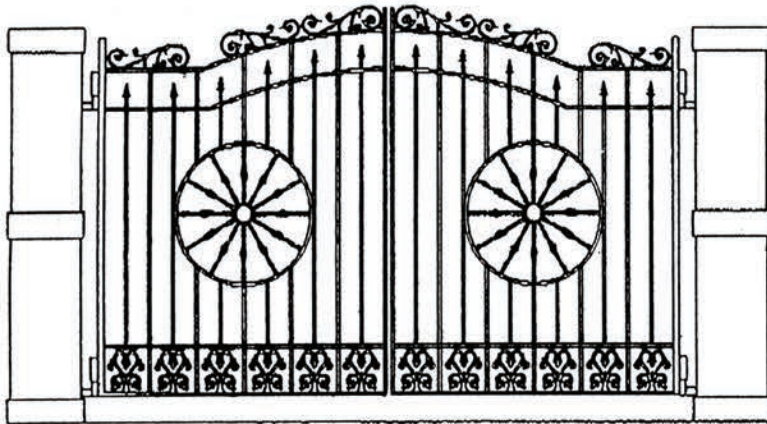

Base Casting #951 Spear #2777 Crown Castings #801  
Medallion Pieces Modified #1341

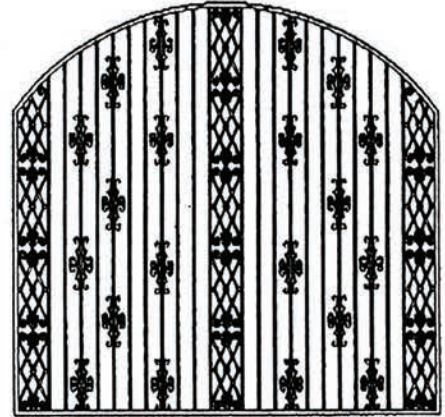

Vertical Borders #960 Snap-ons #2058



Base Castings #938 With #934 On Top

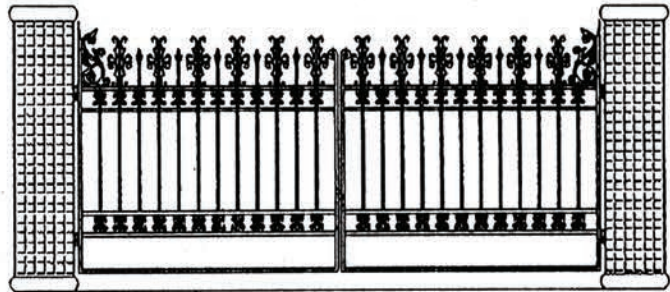

Corner Brackets #1803 Top Snap-ons #2223  
Small Snap-ons #4350 Spears #2779

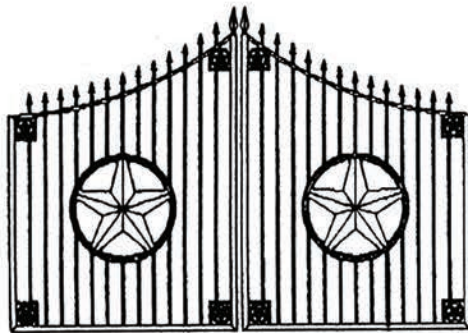

Corner Castings #9237 Large Spear #8209  
Small Spear #2776 Center Medallions #713

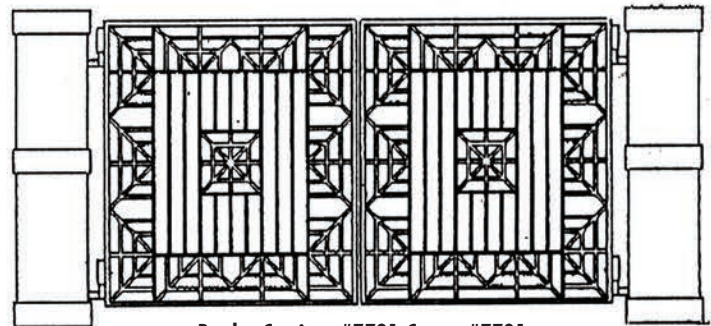

Border Castings #7791 Center #7781



Border Castings #933 Center Medallion #892



Base Spines #9055 Small Snap-ons #10  
Large Snap-on #3003 Spear #8264

# HYSTERICAL H I S T O R Y

**"On March 2, 1836, Texas troops under Sam Houston won independence and shouted out "Remember the Alamo!" When we tried that here, the neighbors complained about the noise."**

These one-of-a-kind plaques, offered exclusively from Alloy Casting and the Hysterical Society of America are sure to cause a double take from everyone who sees them. Made of durable, rustproof aluminum, these hilarious plaques have unique historical facts mixed in with just the right amount of funny fiction. All plaques come ready to hang with an included mounting kit. Large plaques are approximately 8" by 15" and weigh two pounds. Small plaques are 4" by 9" and weigh a half of a pound.

**AT THIS VERY LOCATION  
ON APRIL 12, 1861  
ABSOLUTELY NOTHING  
HAPPENED.**

**#1861  
SMALL PLAQUE - 4" BY 9" / 0.5 LBS**

**TO ORDER OR FOR MORE INFORMATION CALL**

**1.800.527.4727**

**OR VISIT OUR WEB SITE AT [WWW.ALLOYNET.COM](http://WWW.ALLOYNET.COM)**



**#91TX  
LARGE PLAQUE V.1  
8" BY 15" / 2 LBS**



**#92TX  
LARGE PLAQUE V.2  
8" BY 15" / 2 LBS**



**#91FL  
LARGE PLAQUE  
8" BY 15" / 2 LBS**



**#91NM  
LARGE PLAQUE  
8" BY 15" / 2 LBS**



# CHOOSE FROM OVER 35 STATES WITH MORE TO BE ADDED SOON

## ALABAMA

Part no. 91AL

In 1866, the first electric trolley streetcar the United States began in Alabama. If this Building had been here, they could have borrowed an extension cord.

## ARKANSAS

Part no. 91AK

On January 26, 1880, the famous U.S. Army General Douglas MacArthur was born in Little Rock. And, during all the years he lived, he never once visited here.

## ARIZONA

Part no. 91AZ

On July 4, 1888, Juan Leivas roped and Tied a steer at Prescott in America's first Rodeo. With a mortgage like ours we know how the steer felt.

## CALIFORNIA

Part no. 91CA

In 1849 the famous "Gold Rush" changed California forever. Prospectors, known As 49ers, poured into the territory. Today if you dig straight down at this Location don't hit the septic tank.

## COLORADO

Part no. 91CO

In 1858 "Pikes Peak or Bust" was the cry As miners poured into the territory to Seek their fortune.

## DELAWARE

Part no. 91DE

On December 7, 1787 Delaware ratified the Constitution and became the first state admitted into the union. If this building had been here, someone would have thrown a party.

## FLORIDA

Part no. 91FL

On March 3, 1845, Florida became the 27th state. The Seven Year War with the Seminole Indians had ended. Visitors arrived by railroads and steamships, and this building was not yet here.

## GEORGIA

Part no. 91GA

In 1864, General W. T. Sherman burned Atlanta and began his march to the sea. Cotton was king "Gone With the Wind" was Georgia, and this ain't Tara.

## IDAHO

Part no. 91ID

In 1860, prospectors stampeded into Idaho with the discovery of gold on Orofino Creek. To this date not a single nugget has been found at this site.

## ILLINOIS

Part no. 91IL

In 1858, the Lincoln-Douglas debates identified how the issue of slavery was dividing the nation. Had they made their train connection in Chicago both would have had lunch here.

## IOWA

Part no. 91IO

In the 1880s Iowa's farmers began raising hogs on home grown corn, forever changing the state's economy. So while eating here, please don't make a pig of yourself.

## KANSAS

Part no. 91KS

In the 1860's Bat Masterson and Wyatt Earp cleaned up the lawlessness in Dodge City and Abilene. Here you are more than welcome to clean up the kitchen.

## KENTUCKY

Part no. 91KY

In 1875, the first Kentucky Derby was run at Louisville, beginning a great tradition in American sports. At this "Old Kentucky Home" horses must wipe their feet before entering.

## MAINE

Part no. 91ME

In 1770, Burnham Tavern in Machias opened, offering, "Drink for the thirsty, Food for the Hungry, Lodging for the weary, and Good keeping for horses." That offer still applies here.

## LOUISIANA

Part no. 91LA

In 1803 Napoleon sold the entire Louisiana Territory for \$15 million to the United States. That was a much better deal than we got on this property.

## MASSACHUSETTS

Part no. 91MA

On April 18, 1775 Paul Revere made his famous ride to warn his fellow Patriots that the British were coming. Unlike here, we have no warning when visitors are coming.

## MICHIGAN

Part no. 91MI

On 1893 Henry Ford appeared in America's first practical automobile. If this building was here, Mr. Ford could have blocked the driveway and gotten America's first parking ticket.

## MINNESOTA

Part no. 91MN

In 1889, the Mayo Clinic, one of the world's leading medical centers, was established in Minnesota. If this building had been here, they still would not have made a house call.

## MISSISSIPPI V1

Part no. 91MS

In 1894, in Vicksburg, Joseph Biedenharn, a candy store owner, first bottled Coca-Cola. If we had been here then we could have bought a six-pack.

## MISSISSIPPI V2

Part no. 92MS

Admitted as the 20th state on Dec. 10, 1817, the Civil War changed Mississippi Battles raged across the state, replacing the splendor and grace of the old south, and at this location nothing happened.

## MISSOURI

Part no. 91MO

In 1865, the notorious bandit, Jesse James began to terrorize this state. He never tried to rob the people in this building because it was not here.

## NEBRASKA

Part no. 91NE

In 1883, Buffalo Bill's famous Wild West Show was organized at his ranch in North Platte, and this is definitely no a home where the buffalo roam.

## NEVADA

Part no. 91NV

In 1859, silver miners rushed into Nevada after hearing of the incredibly rich Comstock Lode. You are standing at the very location where nothing was found.

## NEW HAMPSHIRE

Part no. 91NH

In 1777, hundreds of New Hampshire "Minute Men" hurried to Boston to fight the British. Here, no one has been in a hurry since.

## NEW JERSEY

Part no. 91NJ

3000 visitors came to Menlo Park in 1879 to witness Thomas Edison's demonstration of the electric light. Today, we would be happy with one visitor who could change a light bulb.

## NEW MEXICO

Part no. 91NM

The Santa Fe Trail was established in 1821, opening a new route to New Mexico. Nowadays, we would be satisfied with a new route to the grocery store.

## NEW YORK

Part no. 91NY

In 1626, Peter Minuit purchased Manhattan Island for roughly \$24 in trinkets. That was a much better deal than we got on this property.

## NORTH CAROLINA

Part no. 91NC

On January 7, 1838, Silver Hill Mine opened near Lexington, becoming the first silver mine in the United States. None of the proceeds were used to purchase this property.

## OHIO

Part no. 91OH

In 1869, the first public weather forecasting service began in Cincinnati. When we watch the weather on TV here, the forecasting is no better than it was then.

## OKLAHOMA

Part no. 91OK

On April 22, 1889, nearly 50,000 settlers poured into Oklahoma as the territory was opened to homesteaders. If this had been built "sooner" one might have settled here.

## PENNSYLVANIA

Part no. 91PA

November 19, 1863, Abraham Lincoln, in his Gettysburg Address, spoke of the struggle of a nation torn apart by civil war, like the struggle here when it's time to clean the bathroom.

## RHODE ISLAND

Part no. 91RI

In 1854, this state contributed greatly to agriculture by the development of a new breed of chicken called the "Rhode Island Red." And if you are not "chicken stay for dinner.

## SOUTH CAROLINA

Part no. 91SC

On April 12, 1861, Confederate Army batteries shelled Fort Sumter in Charleston Harbor, beginning the Civil War. And this building was not here yet.

## TENNESSEE

Part no. 91TN

In the Mexican War 1845, citizens volunteered in such numbers that Tennessee is known as the volunteer state. Here, we can't get a volunteer to take out the garbage.

## TEXAS V1

Part no. 91TX

On April 21, 1836, Texas troops under Sam Houston won independence, as they shouted out "Remember the Alamo." When we tried that here, the neighbors complained about the noise.

## TEXAS V2

Part no. 92TX

On March 2, 1836, Texas declared her independence from Mexico, wild Comanches roamed the plains, Rangers protected frontier settlements, and this building was not here yet..

## UTAH

Part no. 91UT

On May 10, 1869, East met West as the last spike was driven, completing the Union Pacific Railroad. Many years later, the last nail was driven, completing this building.

## VERMONT

Part no. 91VT

On March 4, 1791, after the American Revolution, Vermont became our 14th state. Pioneers on small farms began producing maple syrup and dairy products, and this building was not here yet.

## VIRGINIA

Part no. 91VA

Virginia, 1st of the 13 original colonies, contributed such dedicated statesman as Patrick Henry, George Washington, and Thomas Jefferson to the course of freedom. None of which slept here.

## WEST VIRGINIA

Part no. 91WV

In 1869, the famous abolitionist, John Brown and his followers raided the arsenal at Harper's Ferry. Here, we like to raid the refrigerator.



**Ball Caps:**

SQUARE HOLE SIZE	PART NO. AL 535/
1"	3410
1 1/2"	3415
2"	3420
2 1/2"	3425
3"	3430
4"	3440

**Collars:**

SQUARE HOLE SIZE	PART NO. AL 535/
1/2"	164
5/8"	165
3/4"	143
1"	140



		PART NO. AL 535/
BIG	3/4"	8264
SMALL	3/4"	634

**Welding Wire for Allomet:**



	PART NO. AL 535/
.030"	1030
.035"	1035

ALLOY 5356 FOR ALLOMET 535 SERIES  
 1LB SPOOLS

**Eliminate your powder coat flaking problems.**



Toll Free 800.527.1318 • Fax 972.557.4727  
 Local 972.286.2368 • Alloy.net.com

*"Quality castings on time"*

**Other castings in AlloMet upon request. Call for pricing.**

**Spear Points:**



		PART NO. AL 535/
BIG	3/4"	8215
SMALL	3/4"	8223

**Circles:**

OUTER DIAMETER	PART NO. AL 535/
3 1/2"	7134
3 7/8"	7137
4"	7140
4 1/2"	7144
5 1/4"	7152
5 7/8"	7157

**Post Caps:**

SQUARE HOLE SIZE	PART NO. AL 535/
1"	3301
1 1/2"	3315
2"	3302
2 1/2"	3325
3"	3303
4"	3304
6"	3306

**CORROSION RESISTANT ALUMINUM**





# ALLOY CASTING

Aluminum

Toll Free (800) 527-1318

(972) 286-2368

Fax (972) 557-4727

# SIGN AND MAIL BOX

Posts:

**3"**

**9300 DF**

HEIGHT 24"  
WIDTH 7 1/4"  
THICK 1/4"  
WEIGHT 9 lbs

1 PIECE  
HOLLOW

**9350 DF**

HEIGHT 24"  
WIDTH 7 1/4"  
THICK 1/4"  
WEIGHT 4.3 lbs

2 PIECE SPLIT  
BASE



OPEN 2 3/8"

**998 DF**

HEIGHT 28 1/2"  
WIDTH 6 1/2"  
THICK  
WEIGHT 11.2 lbs



TOP OPEN 2 3/8"  
BOTTOM OPEN 5 5/8"

**997 DF**

HEIGHT 28 1/2"  
WIDTH 6 1/2"  
THICK  
WEIGHT 17.5 lbs



2 PIECE POST  
HOLE 17/8" DIAMETER

**9258 DF**

HEIGHT 31"  
WIDTH 4 1/4"  
THICK  
WEIGHT 18.5 lbs

**4"** **6"** **3"**

**3441 DF** **3460 DF** **3430 DF**

HEIGHT 6"  
WIDTH 4 5/8"  
THICK 4 5/8"  
WEIGHT 2.3 lbs

HEIGHT 9" EST.  
WIDTH 7" EST.  
THICK 7" EST.  
WEIGHT 3 lbs EST.

HEIGHT 4 3/4"  
WIDTH 3 5/8"  
THICK 3 5/8"  
WEIGHT 1.5 lbs

**4"** **3"** **3"**

**3440 DF** **3530 DF** **3531 DF**

HEIGHT 5 5/8"  
WIDTH 4 1/2"  
THICK 4 1/2"  
WEIGHT 2.10 lbs

HEIGHT 6"  
WIDTH 4"  
THICK 1/4" wall  
WEIGHT 1.8 lbs

HEIGHT 6 1/4"  
WIDTH 4 3/4"  
THICK 1/4" wall  
WEIGHT 2.8 lbs

**1"** **3"** **3"**

**9513 DF** **8061 DF** **8042 DF**

HEIGHT 3 3/8"  
WIDTH 2"  
THICK 2"  
WEIGHT 0.60 lbs

HEIGHT 4 3/4"  
WIDTH 3 5/8"  
THICK 3 5/8"  
WEIGHT 1.5 lbs

HEIGHT 4 3/4"  
WIDTH 3 5/8"  
THICK 3 5/8"  
WEIGHT 1.5 lbs

NOTE: DF denotes double face

Ball Tops:

Decorative Designs:

**9733 DF** **3750 DF** **9437 DF**

HEIGHT 3 1/4"  
WIDTH 5 5/8"  
THICK 3/4"  
WEIGHT 0.5 lbs

HEIGHT 23 1/2"  
WIDTH 13 1/2"  
THICK 1 1/2"  
WEIGHT 7.3 lbs

HEIGHT 14 1/2"  
WIDTH 9 1/4"  
THICK 1"  
WEIGHT 2.1 lbs

**2088 DF** **562 DF** **1803 DF**

HEIGHT 12"  
WIDTH 16"  
THICK 1 3/4"  
WEIGHT 4.5 lbs

HEIGHT 6 5/8"  
WIDTH 13 5/8"  
THICK 3/4"  
WEIGHT 0.9 lbs

HEIGHT 9 1/2"  
WIDTH 19"  
THICK 1/2"  
WEIGHT 2.1 lbs

**1852 DF** **9609 DF** **591 DF**

HEIGHT 14 5/8"  
WIDTH 14 5/8"  
THICK 3/4"  
WEIGHT 2.4 lbs

HEIGHT 3 3/4"  
WIDTH 13"  
THICK 1"  
WEIGHT 0.9 lbs

HEIGHT 8"  
WIDTH 13"  
THICK 1"  
WEIGHT 1.2 lbs



## ALUMINUM CASTINGS

Toll Free 800.527.1318 • Fax 972.557.4727

Local 972.286.2368 • Alloy.net.com

*"Quality castings on time"*

Many more decorative pieces  
in full line catalog!

Pineapples:

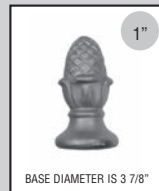

BASE DIAMETER IS 3 7/8"

**8045 DF**

HEIGHT 6 3/4"  
WIDTH 3 7/8"  
THICK 3 7/8"  
WEIGHT 2.7 lbs



BASE DIAMETER IS 2 5/8"

**9570 DF**

HEIGHT 6 1/2"  
WIDTH 3"  
THICK 3"  
WEIGHT 2.6 lbs



BASE DIAMETER IS 1 3/4"

**8025 DF**

HEIGHT 5 1/8"  
WIDTH 2 1/2"  
THICK 2 1/2"  
WEIGHT 1.0 lbs



2 3/8"

**9256 DF**

HEIGHT 7 3/4"  
WIDTH 3 1/2"  
THICK  
WEIGHT 1.6 lbs

Toll Free (800) 527-1318  
 (972) 286-2368  
 Fax (972) 557-4727

**ALLOY CASTING**

Aluminum

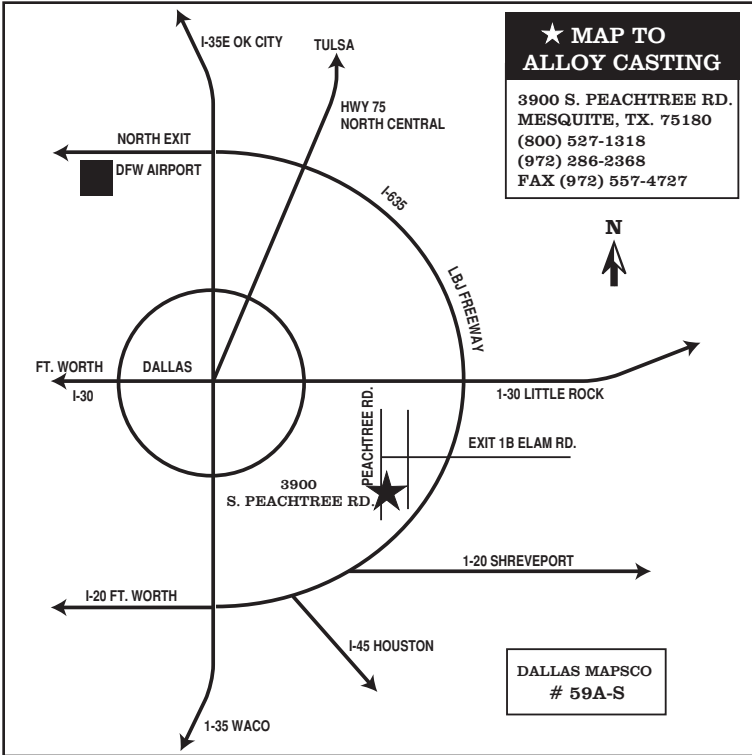

**UPS GROUND**

**Guaranteed Day-Definite Delivery**  
 For commercial shipments originating in Balch Springs, Tx 75180

Legend:  
 1 DAY (darkest grey)  
 2 DAYS (dark grey)  
 3 DAYS (medium grey)  
 4 DAYS (light grey)  
 5 DAYS (white)

**STATE OF TEXAS  
 CERTIFICATE OF RESALE, LEASING OR RENTING  
 TANGIBLE PERSONAL PROPERTY \***

I HEREBY CERTIFY: That I hold Texas Limited Sales Tax Permit No. \_\_\_\_\_ issued pursuant to the Limited Sales, Excise and Use Tax Law, and that the tangible personal property described below or which is shown in the attached order of invoice which is made a part hereof, which I will purchase from **Alloy Casting INC. 3900 S. Peachtree Rd. Mesquite, TX 75180 (972)-286-2368** will be resold, rented or leased by me in the form of tangible personal property; however, if I make any use of the tangible personal property other than retention, demonstration or display while holding it for sale, lease or rental in the regular course of business, the use shall be taxable to me as of the time when the tangible personal property is first so used, and the sales price of the tangible personal property to me shall be deemed the measure of the tax. Description of the property to be purchased: **Aluminum Castings / Hardware**

Executed this the \_\_\_\_\_ day of \_\_\_\_\_, 19\_\_\_\_.

Purchaser \_\_\_\_\_  
 (company or organization)

By \_\_\_\_\_ Title \_\_\_\_\_  
 (signature)

Address \_\_\_\_\_

City/ Zip code \_\_\_\_\_

\* The form must contain the signature and must bear the name and address of the purchaser; it must indicate the number of the permit, if any, issued to the purchaser. It must indicate the general character of the tangible personal property sold, leased or rented by the purchaser in the regular course of business.



# ALLOY CASTING

Aluminum

Toll Free (800) 527-1318

(972) 286-2368

Fax (972) 557-4727

# NEW ASSORTED DESIGNS

DOUBLE FACE

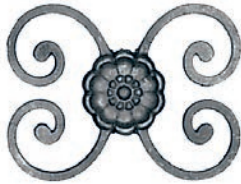

HOLE IS 5/8" X 5/8"  
SQUARE

**1010**

HEIGHT 6"  
WIDTH: 7 3/4"  
THICK: 1 3/4"  
WEIGHT: 1.10 lbs

DOUBLE FACE



HOLE IS 5/8" X 5/8"  
SQUARE

**1011**

HEIGHT 10"  
WIDTH: 8"  
THICK: 1 3/8"  
WEIGHT: 1.50 lbs

DOUBLE FACE



**4482**

HEIGHT 3 5/8"  
WIDTH: 15 1/2"  
THICK: 5/8"  
WEIGHT: .8 lbs

DOUBLE FACE



**4440**

HEIGHT 28 1/4"  
WIDTH: 7 1/2"  
THICK: 1/2"  
WEIGHT: 3.5 lbs

DOUBLE FACE



**1896**

HEIGHT 21 5/8"  
WIDTH: 9 3/8"  
THICK: 3/4"  
WEIGHT: 3.3 lbs

DOUBLE FACE



**1875**

HEIGHT 31 3/8"  
WIDTH: 5 5/8"  
THICK: 3/4"  
WEIGHT: 2.8 lbs

DOUBLE FACE



FEET 1 3/8" DIA

**1886**

HEIGHT 30 3/4"  
WIDTH: 9"  
THICK: 7/8"  
WEIGHT: 4.4 lbs

DOUBLE FACE

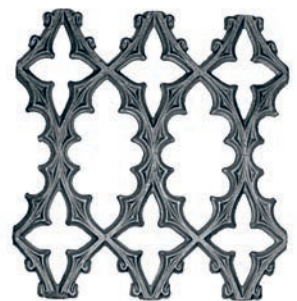

**4450**

HEIGHT 14 5/8"  
WIDTH: 14 1/8"  
THICK: 5/8"  
WEIGHT: 3.6 lbs

DOUBLE FACE



**530**

HEIGHT 9 7/8"  
WIDTH: 5 1/4"  
THICK: 1 1/8"  
WEIGHT: .60 lbs

DOUBLE FACE



STUBS 1/2" BY 1/2" BY  
3/4"L, FITS 3/4 SQ TUBE

**531**

HEIGHT 9"  
WIDTH: 4 3/4"  
THICK: 3/4"  
WEIGHT: .60 lbs

DOUBLE FACE



END COLLAR 1" THICK BY  
7/8" W

**532**

HEIGHT 8 5/8"  
WIDTH: 4 3/8"  
THICK: 5/8"  
WEIGHT: .60 lbs

DOUBLE FACE



END COLLAR 1 3/8"W BY  
1 1/2"T

**541**

HEIGHT 8 3/8"  
WIDTH: 4 5/8"  
THICK: 1 1/2"  
WEIGHT: .90 lbs

NEW ASSORTED DESIGNS

Toll Free (800) 527-1318  
 (972) 286-2368  
 Fax (972) 557-4727

ALLOY CASTING

Aluminum



DOUBLE FACE



**8177**

HEIGHT 4" dia  
 WIDTH: 4" dia  
 THICK: 1"  
 WEIGHT: .70 lbs

FLAT BACK



**8178**

HEIGHT 3 3/4"  
 WIDTH: 3 3/4"  
 THICK: 3/8"  
 WEIGHT: .30 lbs

FLAT BACK



1/2" PICKET

**4483**

HEIGHT 15 1/2"  
 WIDTH: 6 5/8"  
 THICK: 5/8"  
 WEIGHT: 1.0 lbs

DOUBLE FACE



1/2" PICKET

**4449**

HEIGHT 11 3/4"  
 WIDTH: 8"  
 THICK: 3/4"  
 WEIGHT: 1.4 lbs

DOUBLE FACE

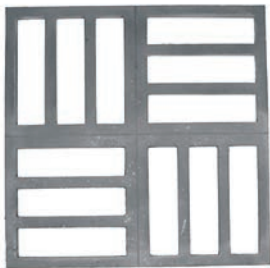

**9369**

HEIGHT 18"  
 WIDTH: 18"  
 THICK: 3/4"  
 WEIGHT: 11.4 lbs

DOUBLE FACE



4" NO PAS-OK

**9295**

HEIGHT 14 1/4"  
 WIDTH: 16 5/8"  
 THICK: 3/4"  
 WEIGHT: 4.7 lbs

DOUBLE FACE



**616**

HEIGHT 14 3/4"  
 WIDTH: 18 3/4"  
 THICK: 5/8"  
 WEIGHT: 3.5 lbs

DOUBLE FACE

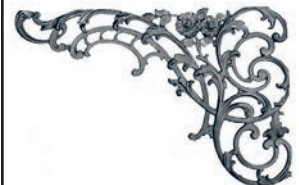

**4683**

HEIGHT 16 3/4"  
 WIDTH: 25 1/2"  
 THICK: 3/4"  
 WEIGHT: 5.2 lbs

DOUBLE FACE



**9603**

HEIGHT 23"  
 WIDTH: 8"  
 THICK: 1/4"  
 WEIGHT: 1.8 lbs

DOUBLE FACE



GRILL BACK HAS RIM 5" BY 14" & 1/8"W BY 1/4"T

**9669**

HEIGHT 6 1/8"  
 WIDTH: 15 1/4"  
 THICK: 1/2"  
 WEIGHT: 1.5 lbs

DOUBLE FACE



SCROLL 1" DIA

**7771**

HEIGHT 26 3/4"  
 WIDTH: 12 1/2"  
 THICK: 2"  
 WEIGHT: 9.1 lbs

FLAT BACK



**9367**

HEIGHT 18"  
 WIDTH: 18 1/4"  
 THICK: 1  
 WEIGHT: 11.7 lbs





# ALLOY CASTING

Aluminum

Toll Free (800) 527-1318

(972) 286-2368

Fax (972) 557-4727

# NEW ASSORTED DESIGNS

**DOUBLE FACE**

**922**

HEIGHT 29 5/8"  
WIDTH: 9 3/8"  
THICK: 1 1/4"  
WEIGHT: 8.7 lbs

**FLAT BACK**

**758**

HEIGHT 27"  
WIDTH: 6 1/2"  
THICK: 5/8"  
WEIGHT: 4.0 lbs

**DOUBLE FACE**

**1938**

HEIGHT 39"  
WIDTH: 9 3/4"  
THICK: 1 1/2"  
WEIGHT: 5.4 lbs

**DOUBLE FACE**

1/2" SLOT

**612**

HEIGHT 16 1/2"  
WIDTH: 5"  
THICK: 7/8"  
WEIGHT: 1.1 lbs

## INDIVIDUAL OR 3 PIECE SET

**FLAT BACK**

**9401**

HEIGHT 30 1/8"  
WIDTH: 15 1/2"  
THICK: 5/8"  
WEIGHT: 7.8 lbs

**FLAT BACK**

**9402**

HEIGHT 30 3/4"  
WIDTH: 14 1/2"  
THICK: 5/8"  
WEIGHT: 4.7 lbs

**FLAT BACK**

**9403**

HEIGHT 29 3/4"  
WIDTH: 15 1/2"  
THICK: 5/8"  
WEIGHT: 8.3 lbs

**HEIGHT**  
**WIDTH:**  
**THICK:**  
**WEIGHT:**

## 2 VIEWS

**DOUBLE FACE**

OPENING OVAL 10" BY 18"W  
BY 3 3/4" BELOW SEAT

**9318**

HEIGHT 14 1/2"  
WIDTH: 22 1/2"  
THICK: 4 1/2"  
WEIGHT: 11.4 lbs

**DOUBLE FACE**

OPENING OVAL 10" BY 18"W  
BY 3 3/4" BELOW SEAT

**9318 SIDE**

HEIGHT 14 1/2"  
WIDTH: 22 1/2"  
THICK: 4 1/2"  
WEIGHT: 11.4 lbs

**DOUBLE FACE**

OPENING 7 3/4" BY 15 1/2"W  
BY 1 1/4" BELOW SEAT

**9718**

HEIGHT 9 5/8"  
WIDTH: 17"  
THICK: 1 7/8"  
WEIGHT: 5.1 lbs

**DOUBLE FACE**

3/4" SQUARE COLLAR

**8229**

HEIGHT 7 1/4"  
WIDTH: 2 1/4"  
THICK: 2 1/4"  
WEIGHT: 1.10 lbs

NEW ASSORTED DESIGNS

Toll Free (800) 527-1318  
 (972) 286-2368  
 Fax (972) 557-4727

ALLOY CASTING

Aluminum



DOUBLE FACE



**4498**

HEIGHT 11"  
 WIDTH: 12"  
 THICK: 3/4"  
 WEIGHT: 2.8 lbs

DOUBLE FACE



2 PC SET

**4751**

HEIGHT 9"  
 WIDTH: 8"  
 THICK: 3"  
 WEIGHT: 1.9 lbs

DOUBLE FACE



2 PC SET

**4766**

HEIGHT 5"  
 WIDTH: 5"  
 THICK: 1 3/4"  
 WEIGHT: 0.5 lbs

DOUBLE FACE



**4761**

HEIGHT 5 1/4"  
 WIDTH: 10 1/4"  
 THICK: 3/4"  
 WEIGHT: .55 lbs

DOUBLE FACE



**4765**

HEIGHT 6 1/4"  
 WIDTH: 10 1/2"  
 THICK: 1"  
 WEIGHT: 1.9 lbs

FLAT BACK



**4633**

HEIGHT 9 1/8"  
 WIDTH: 9 1/4"  
 THICK: 1/4"  
 WEIGHT: 1.0 lbs

DOUBLE FACE



**4454**

HEIGHT 11"  
 WIDTH: 10"  
 THICK: 3/4"  
 WEIGHT: 1.3 lbs

SINGLE FACE



3 PC SET LARGEST SIZE

**4737**

HEIGHT 10"  
 WIDTH: 11"  
 THICK: 1/2"  
 WEIGHT: 1.0 lbs

SIDE BACKED OUT



BEETLE BOOT JACK

**9767**

HEIGHT 10 3/4"  
 WIDTH: 4 7/8"  
 THICK: 2"  
 WEIGHT: 0.9 lbs

DOUBLE FACE



**4767**

HEIGHT 8 7/8"  
 WIDTH: 9"  
 THICK: 7/8"  
 WEIGHT: 1.0 lbs

SIDE BACKED OUT



**4758**

HEIGHT 10 1/2"  
 WIDTH: 12 3/4"  
 THICK: 1/4"  
 WEIGHT: 1 lbs

SIDE BACKED OUT



2 PC SET

**4795**

HEIGHT 10 1/2"  
 WIDTH: 8"  
 THICK: 1/2"  
 WEIGHT: 0.7 lbs



# ALLOY CASTING

Aluminum

Toll Free (800) 527-1318  
(972) 286-2368  
Fax (972) 557-4727

# NEW ASSORTED DESIGNS

**FLAT BACK**

**9378**

HEIGHT 18 1/8"  
WIDTH: 9 1/2"  
THICK: 1/2"  
WEIGHT: 5.1 lbs

**DOUBLE FACE**

**4740**

HEIGHT 2 1/2"  
WIDTH: 17 1/8"  
THICK: 3/8"  
WEIGHT: 0.8 lbs

**DOUBLE FACE**

**4490**

HEIGHT 18"  
WIDTH: 12"  
THICK: 1 1/4"  
WEIGHT: 5.0 lbs

**FLAT BACK**

**9770**

HEIGHT 18 1/4"  
WIDTH: 12 1/2"  
THICK: 3/4"  
WEIGHT: 3.1 lbs

**2 VIEWS**

**DOUBLE FACE**

5 3/4" DEEP

**9089**

HEIGHT 34"  
WIDTH: 8"  
THICK: 5/8"  
WEIGHT: 5.6 lbs

**DOUBLE FACE**

5 3/4" DEEP

**9089 SIDE**

HEIGHT 34"  
WIDTH: 8"  
THICK: 5/8"  
WEIGHT: 5.6 lbs

**FLAT BACK**

1/2" SLOT

**217**

HEIGHT 9 1/8"  
WIDTH: 6 7/8"  
THICK: 1/2"  
WEIGHT: 0.8 lbs

**SINGLE FACE**

**317**

HEIGHT 3 1/2"  
WIDTH: 17 5/8"  
THICK: 5/8"  
WEIGHT: 1.0 lbs

**DOUBLE FACE**

9" POINT TO POINT

**9692**

HEIGHT 10 1/8"  
WIDTH: 18 3/4"  
THICK: 1"  
WEIGHT: 4.8 lbs

**DOUBLE FACE**

**9609**

HEIGHT 13"  
WIDTH: 3 1/2"  
THICK: 1"  
WEIGHT: 1.0 lbs

**DOUBLE FACE**

1 3/4"L BY 3 1/2" DIA W/  
2" SQUARE HOLE

**9709**

HEIGHT 11 1/2"  
WIDTH: 6 dia"  
THICK: 1"  
WEIGHT: 17.0 lbs

**DOUBLE FACE**

**9746**

HEIGHT 29 3/8"  
WIDTH: 6 1/4"  
THICK: 7/8"  
WEIGHT: 4.2 lbs



DOUBLE FACE



9/16" FACE

**1878**

HEIGHT 26"  
 WIDTH: 11 3/8"  
 THICK: 1/2"  
 WEIGHT: 4.2 lbs

DOUBLE FACE



**1879**

HEIGHT 38 3/8"  
 WIDTH: 11 1/4"  
 THICK: 1/2"  
 WEIGHT: 9.5 lbs

DOUBLE FACE



3/8" DIA HOLE

**1908**

HEIGHT 4 1/2"  
 WIDTH: 1 3/4" dia base  
 THICK: 1/2"  
 WEIGHT: 0.4 lbs

DOUBLE FACE



1/4" DIA HOLE

**1914**

HEIGHT 6 1/4"  
 WIDTH: 2 1/2" dia base  
 THICK: 1/2"  
 WEIGHT: 1.1 lbs

DOUBLE FACE



**1930**

HEIGHT 23 3/4"  
 WIDTH: 7 1/4"  
 THICK: 1"  
 WEIGHT: 2.1 lbs



HEIGHT 1" OVER SEAT; STUB  
 7/8" BY 7/8" BY 3/4"H FOR  
 16 GA. TUBING

**9271**

HEIGHT 1 3/4"  
 WIDTH: 1"  
 THICK: 1"  
 WEIGHT: 0.1 lbs



Y PLUG, 1/2"L. 1/8" WALL

**1404**

HEIGHT 1 15/16"OD  
 WIDTH:  
 THICK: 1"  
 WEIGHT: 0.1 lbs

DOUBLE FACE



**1408**

HEIGHT 2 3/8"OD  
 WIDTH:  
 THICK: 3/4" over seat  
 WEIGHT: 0.25 lbs



**9112**

HEIGHT 2 3/8" dia.  
 2" over seat  
 THICK:  
 WEIGHT: 0.25 lbs

DOUBLE FACE



PIPE OD 3 1/4", PIPE ID 3

**4392**

HEIGHT 3 7/8"OD  
 WIDTH:  
 THICK: 1 1/4" HIGH  
 WEIGHT: 0.5 lbs

DOUBLE FACE 3/4" □



**8278**

HEIGHT: 5 3/4"  
 WIDTH: 1 3/4"  
 THICK: 1 1/2"  
 WEIGHT: 0.5 lbs

DOUBLE FACE 1/2" □



**8280**

HEIGHT 4 1/2"  
 WIDTH: 2 1/2"  
 THICK: 1  
 WEIGHT: 0.2 lbs





# ALLOY CASTING

Aluminum

Toll Free (800) 527-1318

(972) 286-2368

Fax (972) 557-4727

# NEW ASSORTED DESIGNS

DOUBLE FACE



NO CLIP DIAMOND 1/2" SLOT

**710**

HEIGHT 3 7/8"  
WIDTH: 5"  
THICK: 1"  
WEIGHT: 0.3 lbs

DOUBLE FACE



NO CLIP DIAMOND 1/2" SLOT

**703**

HEIGHT 15"  
WIDTH: 8 1/2"  
THICK: 1"  
WEIGHT: 1.3 lbs

DOUBLE FACE



SLOT 3/4" SQ HOLE

**9634**

HEIGHT 20 7/8"  
WIDTH: 8 1/2"  
THICK: 1 1/2"  
WEIGHT: 5.1 lbs

DOUBLE FACE



DIAMOND 9/16" SIDES

**1925**

HEIGHT 30 1/4"  
WIDTH: 9 1/8"  
THICK: 1 5/8"  
WEIGHT: 3.2 lbs

DOUBLE FACE



**1916**

HEIGHT 25 1/2"  
WIDTH: 13 1/8"  
THICK: 5/8"  
WEIGHT: 6.1 lbs

DOUBLE FACE



**1931**

HEIGHT 27 1/8"  
WIDTH: 10 1/8"  
THICK: 3/4"  
WEIGHT: 5.7 lbs

DOUBLE FACE



**869**

HEIGHT 28 1/4"  
WIDTH: 14 1/4"  
THICK: 3/8"  
WEIGHT: 4.4 lbs

DOUBLE FACE



BASE 3 1/2" DIA

**8037**

HEIGHT 10 1/8"  
WIDTH: 4 dia"  
THICK: 5/8"  
WEIGHT: 5.2 lbs

DOUBLE FACE



**9547**

HEIGHT 26 1/2"  
WIDTH: 11 5/8"  
THICK: 5/8"  
WEIGHT: 4.4 lbs

SINGLE FACE



3/4" SLOT

**9020**

HEIGHT 16 1/4"  
WIDTH: 7 1/4"  
THICK: 3/4"  
WEIGHT: 1.2 lbs

SINGLE FACE



5/8" SLOT

**9085**

HEIGHT 16"  
WIDTH: 7"  
THICK: 3/4"  
WEIGHT: 1.20 lbs

SINGLE FACE



1" SLOT

**2120**

HEIGHT 16 1/8"  
WIDTH: 7 1/2"  
THICK: 3/4"  
WEIGHT: 1.20 lbs

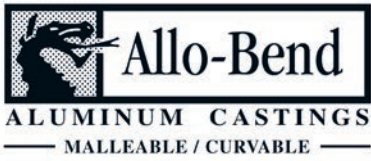

**#2946 DOUBLE FACE**

45 3/4 L  
3 W  
5/8 t  
1.50 lbs



**#0936 DOUBLE FACE**

29 1/8 L  
13 1/2 W  
5/8 t  
6.3 lbs



**#0931 DOUBLE FACE**

29 1/2 L  
14 W  
5/8 t  
4.9lbs



**#0932 DOUBLE FACE**

28 5/8 L  
14 W  
5/8 t  
5.2 lbs



**#0939 DOUBLE FACE**

29 1/8 L  
13 1/2 W  
3/4 t  
9.20 lbs



**#2934 DOUBLE FACE**

34 L  
13 3/4 W  
5/8 t  
4.9 lbs  
for 36" rail



**#2937 DOUBLE FACE**

37 L  
9 1/2 W  
5/8 t  
3.5 lbs  
for 42" rail





# ALLOY CASTING

Aluminum

Toll Free (800) 527-1318

(972) 286-2368

Fax (972) 557-4727

## ROMAN SERIES ALL ITEMS 4" SAFE



**Allo-Custom**  
ALUMINUM CASTINGS  
— CUSTOM CASTINGS —



**Allo-Marine**  
ALUMINUM CASTINGS  
— CORROSION RESISTANT —



**Allo-Bend**  
ALUMINUM CASTINGS  
— MALLEABLE / CURVABLE —

### #0930 DOUBLE FACE

29 L  
14 W  
5/8 t  
4.5 lbs



### #0934 DOUBLE FACE

29 1/2 L  
14 1/4 W  
5/8 t  
4.6 lbs

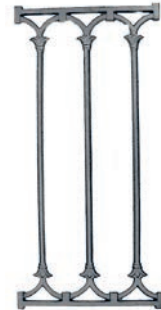

### #0927 DOUBLE FACE

27 L  
9 1/4 W  
5/8 t  
3.10 lbs  
27° pitch 23" vertical



### #2928 DOUBLE FACE

sizes estimated  
33 1/2 L  
8 3/4 W  
5/8 t  
3.5 lbs  
34° pitch 28" vertical



### #0937 DOUBLE FACE

37 L  
8 W  
5/8 t  
3.3 lbs  
45° pitch 29 1/2" vertical



### #0938 DOUBLE FACE

3 1/4 L  
41 1/4 W  
5/8 t  
4.5 lbs



### #2938 DOUBLE FACE

4 1/4 L  
40 1/8 W  
5/8 t  
3.5 lbs



# BENDABLE CASTINGS

Toll Free (800) 527-1318  
(972) 286-2368  
Fax (972) 557-4727

## ALLOY CASTING

Aluminum

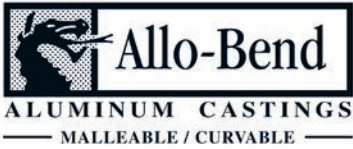
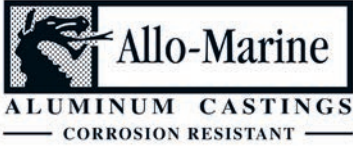

**9493** 36" long leaf bent into spiral  
4 x 39 x 1/4 thick

**9493** Curved with 3" radius  
4 x 39 x 1/4 thick

**938** curved with 12" radius  
3 x 41 x 5/8 thick

**9974** bent into 4" arc  
**PROPRIETARY**  
26 sq x 3/4 thick

**934** bent into a 3" arc  
13 3/4 x 29 x 5/8 thick

**Note:**  
**EXAMPLES OF**  
**BENDABLE APPLICATIONS**

*Many catalog items  
can be made in  
Bendable metal  
for design application.*

*Call to discuss*





# ALLOY CASTING

Aluminum

Toll Free (800) 527-1318

(972) 286-2368

Fax (972) 557-4727

## MAILBOX PARTS

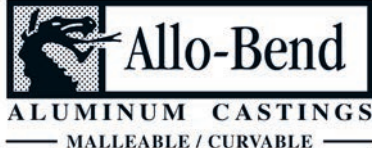

See Horse Designs  
Page 131



#9400 DOUBLE FACE



For 4" dia tubing  
8" dia at base  
25" H

#9429  
For 4" tubing



8 3/8 H  
5 1/2 W  
2.3lbs

IN DEVELOPMENT

#9033 double face

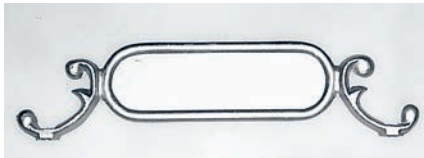

3 3/4 H  
16 W  
3/4 thick  
1 lb  
sign surface 2 1/4 X 8

#2094 double face



12 H  
15 3/4 W  
1 5/8 thick  
5.4 lbs  
sign surface 4x12

#2083 double face



12 1/2 H  
15 3/4 W  
1 5/8 thick  
5.6 lbs  
sign surface 4x12

#2084 double face



13 H  
15 3/4 W  
1 5/8 thick  
5.1 lbs  
sign surface 4x12

#4439 double face



11 1/2 H  
16 1/4 W  
2 thick  
2.9 lbs  
sign surface 8x13

#3088 double face



12 H  
19 3/4 W  
1 1/2 thick  
3.9 lbs  
sign surface 6x18

#1088 double face



8 1/2 H  
16 1/2 W  
1 5/8 thick  
2.5 lbs  
sign surface 7x13

#2088 double face



12 1/8 H  
16 W  
1 5/8 thick  
2.5 lbs  
sign surface 4x12

#2093 double face



12 H  
15 3/4 W  
1 5/8 thick  
6.1 lbs  
sign surface 4x12



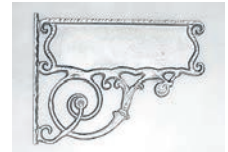

#2091 double face



12 H  
15 3/4 W  
1 5/8 thick  
5.4 lbs  
sign surface 4x12



LEAVES

<p>#9741 double face</p>  <p>H= 3 3/8                  W= 1 7/8                  T= 3/16                  WT= .15 LBS</p>	<p>#9742 double face</p>  <p>H= 4 1/2"                  W=4"                  T= 1/2                  WT= .15 LBS                  1/2" deep</p>	<p>#9743 double face</p>  <p>H=8 3/4                  W=2 1/2"                  T= 5/8 DEEP                  WT= .20 LBS</p>	<p>#9482 double face</p>  <p>H= 6 1/2" each                  W= 5 3/4" each                  WT = .2 lbs. each                  2" deep                  each cast leaf pair</p>	<p>#9483 double face</p>  <p>H= 5" each                  W= 5/34" each                  WT= .151bs each                  1 1/2" deep                  each cast leaf pair</p>
--	---	---	--	--

BATWING

1" thick  
 In strong

Marine Grade aluminum

#1240 1241  
 1" thick



SHOES

#8417



Double Face H= 2 1/8"  
 W= 6 5/8"  
 WT= .9lb.  
 3" deep  
 1 X 2" square

TASSELS

#1908 double face





4 1/2 h  
 1 3/4 dia base  
 .40 lb



#1914 double face



6 1/4 h  
 2 1/4 dia base  
 1.10 lb

BOATING

<p>#4720</p>  <p>L 24                  W 8                  WT= 1.5 LBS</p>	<p>#4750</p>  <p>L 12 1/2                  W 8                  WT= .50 LBS</p>	<p>#4783</p>  <p>L 11 1/2                  W 8                  WT= .50 LBS</p>
--	--	--

<p>#1424</p>  <p>L 6 5/8                  W 8 1/2                  WT= .20 LBS</p>	<p>#4791</p>  <p>L 7 3/4                  W 8 3/4                  WT= .50LBS</p>
--	--



# ALLOY CASTING

Aluminum

Toll Free (800) 527-1318  
(972) 286-2368  
Fax (972) 557-4727

# PALMS & SEA SHELLS



#1457 with 1458

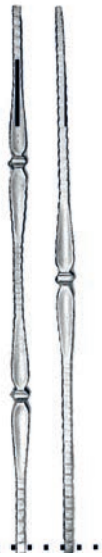

#1457  
New Double Collar  
39" high  
1 1/4 dia,  
1.6 lbs  
Double Face  
ends 7/16 square

#1458  
Single Collar  
see catalog

#2161 with 2162



#2162  
New Double Collar  
40 3/4 high  
1 3/8 dia.  
1.9 lbs  
Double Face  
ends 3/8 dia.

#2161  
Single Collar  
see catalog

#3765

light weight hollow seashell  
goes together back to back  
20 5/8 high  
19 wide  
3 thick  
13 lbs

SOLID Seashell #3725  
See catalog pg 64



Goes together back to back

## BIG and GREAT FOR

#3782  
26 1/2 high  
27 wide  
1/2 thick  
14 lb  
flat back

#3783 mirror image



#3792  
31 1/4 high  
13 1/2 wide  
1/2 thick  
5 lb  
flat back

#3793 mirror image



#3782/3792  
combo  
2 piece palm tree  
45" tall



#3783/3793  
combo  
2 piece palm tree  
45" tall





**Allo-Custom**  
ALUMINUM CASTINGS  
— CUSTOM CASTINGS —

**Allo-Marine**  
ALUMINUM CASTINGS  
— CORROSION RESISTANT —

**Allo-Bend**  
ALUMINUM CASTINGS  
— MALLEABLE / CURVABLE —

**RINGS**



<u>RING DIA</u>	<u>FACE WIDTH</u>		<u>PART #</u>
22	1		#7022
22	1/2		#7122
21	3/4	DF	#7121
15	1/2		#7115
12	1 1/2		#7112
	1/2		#7111
10	1		#7010
10	1/2		#7110
8	1/2		#7180
7	1/2		#7170
6	3/4		#7146
5 7/8	1/2		#7157
5 1/4	1/2		#7152
5	3/4	DF	#7153 *
5	1/2		#7150
4 7/8	1/2	DF	#7147 *
4 1/2			#7144
4			#7140
3 7/8			#7137
3 7/8		DF	#2137
3 1/2		DF	#9775
3 1/2		DF	#9334
3 1/2			#7134
3			#7130

\* IN DEVELOPMENT

DF-Double Face

<b>BALL COLLARS SQUARE HOLE</b>			<b>BALL FINIALS SQUARE HOLE</b>		
<u>SQUARE BAR SIZE</u>	<u>BALL DIA</u>	<u>PART #</u>	<u>SQUARE BAR SIZE</u>	<u>BALL DIA</u>	<u>PART #</u>
1/2	1 1/4	#8344	1/2	1 1/4	#8374
5/8	1 1/2	#8345	5/8	1 1/2	#8375
3/4	2	#8346	3/4	2	#8376
1	2 5/8	#8340	1	2 5/8	#8370

<b>BALL COLLARS ROUND HOLE</b>			<b>BALL FINIALS ROUND HOLE</b>		
<u>ROUND BAR SIZE</u>	<u>BALL DIA</u>	<u>PART #</u>	<u>ROUND BAR SIZE</u>	<u>BALL DIA</u>	<u>PART #</u>
1/2	1 1/4	#8384	1/2	1 1/4	#8394
5/8	1 1/2	#8385	5/8	1 1/2	#8395
3/4	2	#8386	3/4	2	#8396
1	2 5/8	#8380		2 5/8	#8390

<b>BEVELED STAR WITH RING</b>	<u>RING DIA.</u>	<u>PART #</u>
	48	#0714
	36	#0713
	24	#0712
	11 5/8	#0711
	11 5/8	DF #8443
	6 3/4	DF #9237
	5 5/8	#8402
	5 5/8	DF #8442
	5	#9618
	3 1/2	#9734





# ALLOY CASTING

Aluminum

Toll Free (800) 527-1318  
(972) 286-2368  
Fax (972) 557-4727

## DIPTYCH PANELS

### DIPTYCH \* DESIGNS

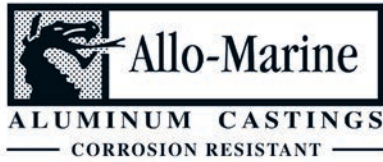

\* **Diptych**- a set of two side-by-side panels bearing pictures of art or carvings

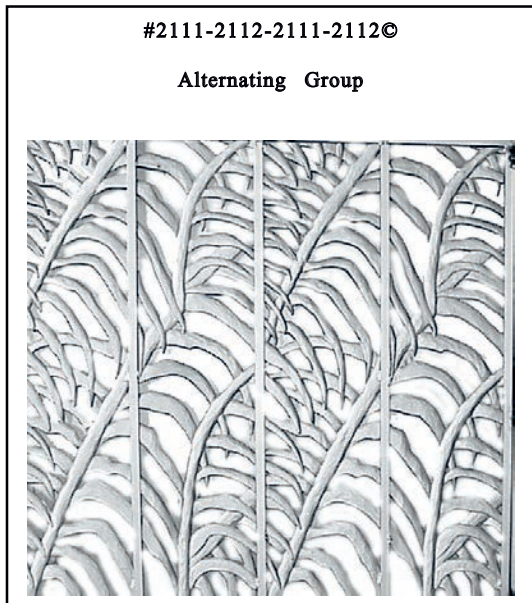
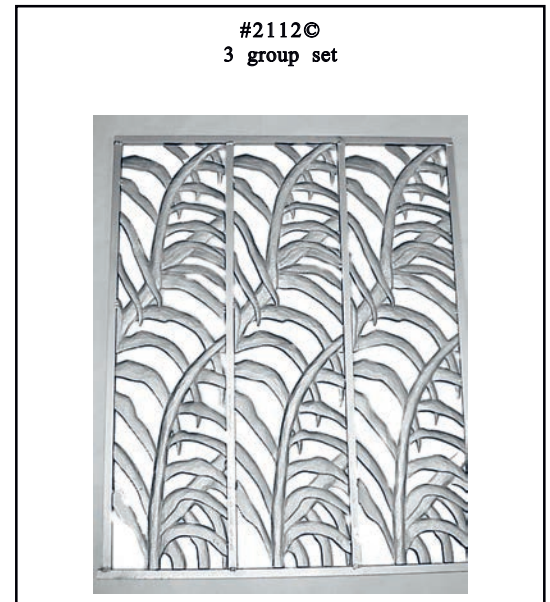
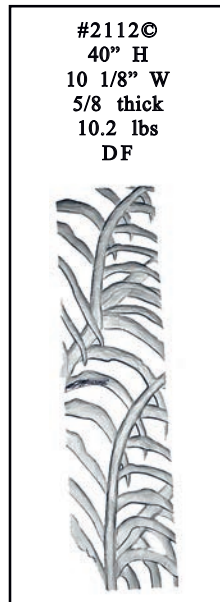
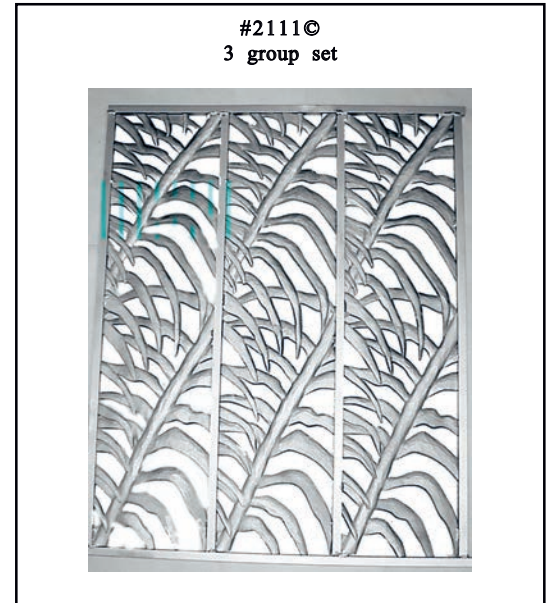
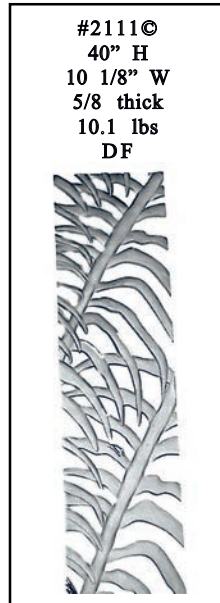

The leaf patterns have been designed to incorporate a 3/4" picket spacing.

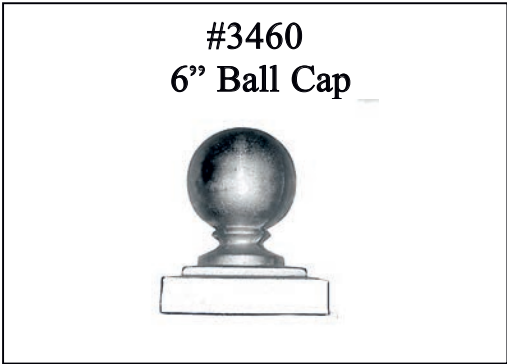
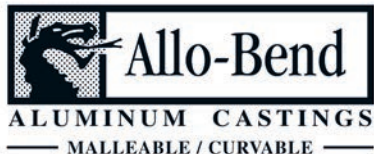

#3460  
6" Ball Cap



#3305  
5" Post Caps

**POST CAPS**  
Very new 5" 3305  
Also available  
New 6" 3306  
New 8" 3308



#7286  
New 3/4 square collar

**Lo Profile Collars**  
1/2 sq. 7284 (old 7782)  
5/8 sq. 7285 (NEW larger)  
5/8 sq. 7765 (smaller old)  
3/4 sq. 7286 (old 7786)  
1 sq. 7288 New



NEW DESIGN  
#1843  
3/4 COLLAR

See our web site  
[www.alloynet.com](http://www.alloynet.com)  
Alloy Castings Inc  
3900 South Peachtree Road  
Mesquite TX 75180



# ALLOY CASTING

Aluminum

Toll Free (800) 527-1318  
(972) 286-2368  
Fax (972) 557-4727

## SCREW ON COLLARS



### NEW PRODUCTS SCREW ON COLLARS

**-Reduce Clean-Up Labor Costs-**

**Set screws on opposite side of collar to give double bite.**

**Visually hidden from above**

**Set screws 1/4-20 use 1/8" hex tool**

**Various lengths**

**(over 3/16L) to match**

**as close as possible to surface**

Full Collar Side Views

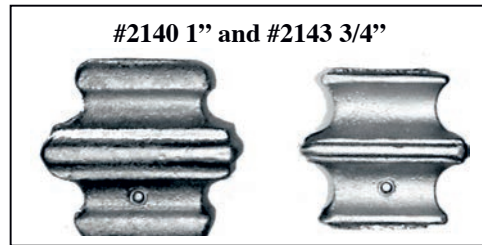

Lo Profile Side View



See our web site

[www.alloynet.com](http://www.alloynet.com)

Alloy Castings Inc

3900 South Peachtree Road

Mesquite TX 75180

**Perfect for  
Mechanical Rail**

Other

SCREW ON COLLARS

AVAILABLE

For 1/2" square and

5/8" square

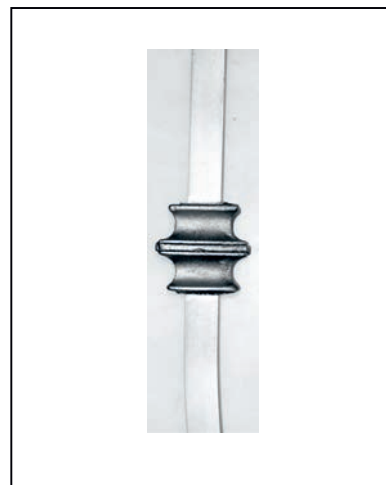

**Front Face  
View**

# 42" RAILING

Toll Free (800) 527-1318  
 (972) 286-2368  
 Fax (972) 557-4727

## ALLOY CASTING

Aluminum

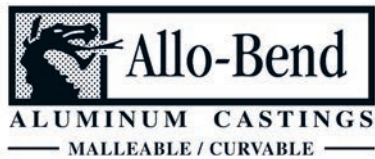



**TRADITIONAL GUARDIAN CASTING**  
 NOW AVAILABLE AS 2pc for 42" HIGH rail #4202  
**-DOUBLE FACE-**  
 4" safe with touching adjacent pickets

**REDUCE FABRICATION COST PRODUCTS NOW AVAILABLE**

Drop In panels with Big Foot for 42" high rail  
 Top rail/castings/bottom rail  
 No cost of intermediate rail meets 4" code with side pickets  
 castings nominal dimensions:  
 8-10" wide x 39 1/2 high x 3/4" thick

See our web site  
[www.alloynet.com](http://www.alloynet.com)

Alloy Castings Inc  
 3900 South Peachtree Road  
 Mesquite TX 75180

<p>4202 double face                  39 1/4 L w/o <b>Big Foot</b>                  41 1/2 w/<b>Big Foot</b>                  3/4 thick                  5 3/4 W                  5.2 lbs.</p> 	<p>4202 (2 pieces)                  with 3 pickets</p> 	<p>4202 (2 pieces)                  with 2 pickets</p> 
---	---	--





# ALLOY CASTING

Aluminum

Toll Free (800) 527-1318  
(972) 286-2368  
Fax (972) 557-4727

# HOLLOW TUBES ALUMINUM BALUSTERS

## Hollow tube Aluminum Balusters

1/16" wall 35" long

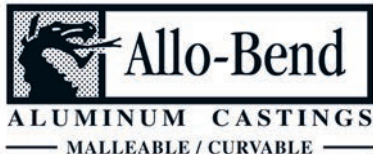

See our web site

[www.alloynet.com](http://www.alloynet.com)

Alloy Castings Inc

3900 South Peachtree Road

Mesquite TX 75180

**#1981**  
35 L  
1 1/4dia  
.8 lbs  
1/16 wall  
1 1/4 end dia



**#1982**  
35 L  
1 1/4dia  
.8 lbs  
1/16 wall  
1 1/4 end dia



**#1983**  
35 L  
1 1/8 dia  
.8 lbs  
1/16 wall  
5/8 end dia



Similar designs as solid aluminum  
Castings #9055 and #9056  
Page 113 of our catalog



Date		<b>Please Deliver FAX To:</b>
Time		Name
From: Jon McGraw		Company
FAX: <b>972-557-4727</b>		Fax #
Alloy Castings: 800-527-1318		

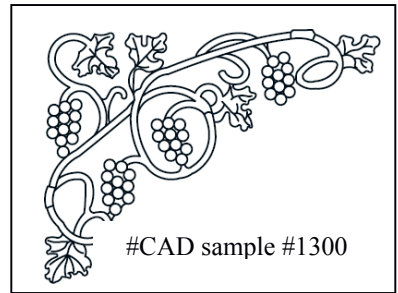

**WE ARE NOW CAD/CAM CAPABLE  
FOR NEW PATTERNS AND TOOLING**

**FAST- ACCURATE- SIMPLE**

**EMAIL YOUR 3 D DIGITAL MODEL FILES IN STP  
WE CAN QUICKLY AND ECONOMICALLY TRANSFORM YOUR DATA  
INTO WORKABLE PATTERNS AND TOOLING**

**WE CAN ALSO PROVIDE 2D OR 3D DIGITAL MODELS  
FROM SKETCHES OR ENGINEERING DRAWINGS  
WHICH YOU CAN PREVIEW  
BEFORE THE PART IS FABRICATED**

**COMPATIBLE WITH MOST 3D MODELING SOFTWARE INCLUDING  
AUTOCAD/ TURBOCAD/ PLASMACAD/ RHINO/ SOLID WORKS**

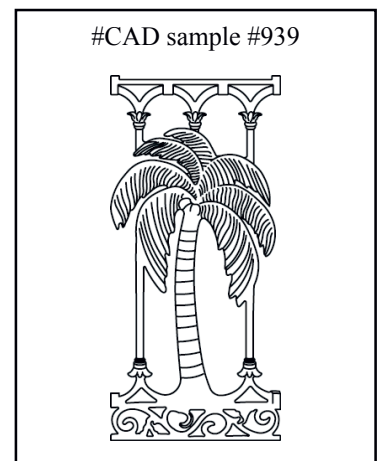
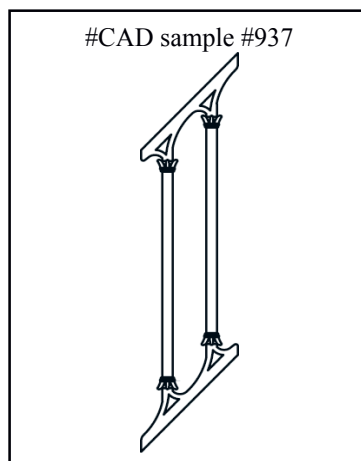
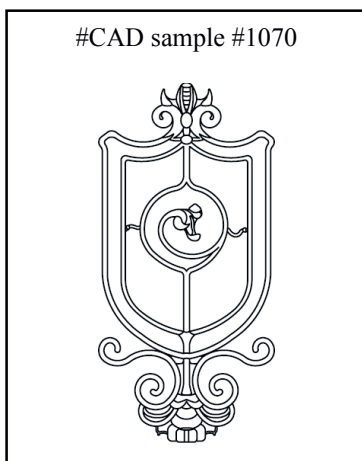

See our web site  
[www.alloynet.com](http://www.alloynet.com)

Alloy Castings Inc  
3900 South Peachtree Road  
Mesquite TX 75180



If you would like to be removed from this FAX list please call 1-800-527-1318



American Made  
 American Quality  
 American Deliveries

*"Quality Castings On Time"*



ALUMINUM CASTINGS

## CIRCUMSCRIBED DESIGNS

Frame 5/8 thick with 5/8 face

#9281  
 10 3/4 H  
 10 3/4 W  
 7/8 T  
 4.70 lbs  
 4.71



#2290  
 Blank Opening 8 3/8 ID  
 10 3/8 H  
 10 3/8 W  
 5/8 T  
 2.4 lbs



#2291  
 Beveled Star  
 10 3/8 H  
 10 3/8 W  
 5/8 T  
 3.4 lbs



#2292  
 Ribbed Star  
 10 3/8 H  
 10 3/8 W  
 5/8 T  
 3.5 lbs



#2293  
 10 3/8 H  
 10 3/8 W  
 5/8 T  
 3.4 lbs



#2294  
 10 3/8 H  
 10 3/8 W  
 1 1/4 T  
 4.8 lbs



#2295  
 10 3/8 H  
 10 3/8 W  
 5/8 T  
 3.5 lbs



#2296  
 10 3/8 H  
 10 3/8 W  
 5/8 T  
 2.9 Lbs







See our web site  
[www.alloynet.com](http://www.alloynet.com)

Alloy Castings Inc  
 1-800-527-1318  
 3900 South Peachtree Road  
 Mesquite TX 75180





**NEW COLLARS  
FOR 5/8"  
AND  
3/4"**

<p>3 3/4 DIA H 3 3/4 DIA W 1 3/4 T 1.10 lbs Double Face</p> 	<p>2 5/8 DIA H 2 5/8 DIA W 1 1/4 T .40 lbs Double Face</p> 	<p>3 1/2 H 3 1/2 W 2 1/4 T 1.00 lbs Double Face</p> 	<p>3 1/2 DIA H 3 1/2 DIA W 2.0 T 1.50 lbs Double Face</p> 	<p>6 7/8 H 5 1/4 W 2 1/4 T 1.3 lbs Double Face</p> 
---	--	---	---	--

5/8 SQUARE	1855	1854	1857	1858	1859
5/8 ROUND	1825	1824	1827	1828	1829
3/4 SQUARE	1445	1444	1447	1448	1449
3/4 ROUND	1395	1394	1397	1398	1399

**ALL CASTING CAN BE MADE IN MARINE GRADE ALUMINUM**

See our web site  
[www.alloynet.com](http://www.alloynet.com)

Alloy Castings Inc  
3900 South Peachtree Road  
Mesquite TX 75180







American Made  
 American Quality  
 American Deliveries





**"Quality Castings On Time"**

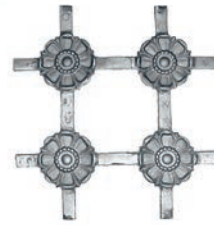

## LATTICE COLLARS EASY AND QUICK SET UPS

Square and Round Holes  
 One direction hole through,  
 Other direction hole partially through



2 5/8 DIA H 2 5/8 DIA W 1 1/4 T .35 lbs Double Face 	3 3/4 DIA H 3 3/4 DIA W 1 3/4 T 1 lb Double Face 	3 1/2 H 3 1/2 W 2 1/4 T 1. lbs Double Face 	3 1/2 DIA H 3 1/2 DIA W 2 T 1.4 lbs Double Face 
--	---	--	--

5/8 SQUARE	2513	2512	2514	2515
5/8 ROUND	2523	2522	2524	2525
3/4 SQUARE	2613	2612	2614	2615
3/4 ROUND	2603	2602	2604	2605

Lattice Ball Collars  
 Square and Round Holes  
 One direction hole through,  
 Other direction hole partially through



1/2 SQUARE	2474	1/2 ROUND	2464
5/8 SQUARE	2475	5/8 ROUND	2465
3/4 SQUARE	2476	3/4 ROUND	2466
1 " SQUARE	2478	1 " ROUND	2468

## ALL CASTING CAN BE MADE IN MARINE GRADE ALUMINUM



See our web site  
[www.alloynet.com](http://www.alloynet.com)

Alloy Castings Inc  
 3900 South Peachtree Road  
 Mesquite TX 75180







## ALL CAST LEAVES CAN BE MADE IN BENDABLE ALUMINUM FOR SMALL BENDS



<p>#9482 DF NO DETAIL ON BACK 6 1/2 H 5 1/2 W 3/16, 1 3/4 T .2 lbs 0.10 lbs</p> 	<p>#9483 DF NO DETAIL ON BACK 5 1/4 H 5 1/4 W 3/16, 1 1/2 T .15 lbs</p> 
---	---

#9741 DF  
3/4 L  
1 7/8 W  
5/8 T  
curved  
.1 lbs



#9742 DF  
4 3/8 L  
3 7/8 W  
1/2 T  
Slight curved  
.2 lbs



<p>#2631 DF 6 L 1 1/2 W 1 3/8 T .2 lbs</p> 	<p>#2632 DF 8 1/2 L 3 W 2 T .4 lbs</p> 	<p>#2633 DF 10 1/2 L 2 3/4 W 2 T .5 lbs</p> 
--	--	---

#9743 DF  
8 3/4 L  
2 1/2 W  
1/2 T  
curved  
.3 lbs



## ALL CASTING CAN BE MADE IN MARINE GRADE ALUMINUM

See our web site  
[www.alloynet.com](http://www.alloynet.com)

Alloy Castings Inc  
3900 South Peachtree Road  
Mesquite TX 75180





American Made  
 American Quality **"Quality Castings On Time"**  
 American Deliveries



**ALL CAST LEAVES CAN BE MADE IN BENDABLE ALUMINUM FOR SLIGHT BENDS**

### CAST LEAVES

#2331 Flat Back 6 3/8 L 2 W 3/16 T .1 lbs	#2332 Flat Back 8 3/4 L 4 W 1/4 T .5 lbs	#2333 Flat Back 10 3/8 L 4 1/8 W 1/4 T .6 lbs
--	---	--



#9089  
 34 H  
 8 W  
 5/8 T  
 5.6 lbs  
 5 3/4 deep



#9089  
Side View



### FORGED LEAVES

#2711 4 3/4 H 2 W 1/8 T 0.10 lbs	#2712 4 3/4 H 2 W 1/8 T 0.10 lb
#2714 2 1/2 H 2 1/4 W 1/16 T 0.10 lbs	#2715 2 1/2 H 2 1/4 W 1/16 T 0.10 lbs

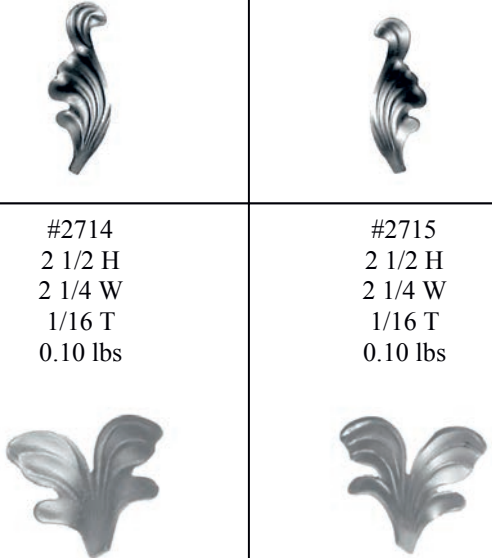

### STAMPED LEAVES

#1271 5 1/2 H 3 W 1/16 T 0.10 lbs	#1272 5 1/2 H 3 W 1/16 T .10 lbs	#1276 9 H 2/78 W 1/16 T 0.10 lbs
---	--	--



**ALL CASTING CAN BE MADE IN MARINE GRADE ALUMINUM**

See our web site  
[www.alloynet.com](http://www.alloynet.com)

Alloy Castings Inc  
 3900 South Peachtree Road  
 Mesquite TX 75180

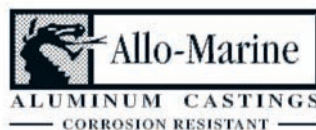

# Understanding Custom Castings

While many variables come into play in determining costs, ultimately the project is a success if end user needs are met at an acceptable price.

By Jon P. McGraw  
Alloy Casting Co.

This article originally printed in the 1992 November-December issue of Fabricator Magazine, an official publication of the National Ornamental & Miscellaneous Metals Association.

**C**ustom designed aluminum casting can be produced in a wide range of sizes, weights, and shapes for any type of ornamental application.

The front end cost of creating the master pattern and the production tooling are an important consideration to the project's total cost and can range from 3 percent to 90 percent of that total. These costs are typically overcome by the customer's desire for a product that is unique and aesthetically pleasing.

This article will outline some of the extremes that we have encountered in custom designed castings. We have completed jobs that range from 1 inch by 1 inch by 2 inches to 48 inches by 48 inches by 2 inches and from weights of .2 pounds to 250 pounds, and from 4 pieces to 10,000 pieces.

These jobs have had tooling charges of 3 percent to 90 percent of the total project cost. In all cases the casting was original and achieved the cost-beauty relationship the fabricator needed to please the customer.

Custom casting projects arrive at the foundry in many forms, including a sketch on an envelope, an engineered drawing, a miniature model, or a full scale model. In each case, the foundry was able to use wood carvers, pattern makers, and shop personnel to create the master patterns and production tooling.

Figure 1 shows some of the small items that we've custom produced. Typically these small aluminum castings are in the range of .2 to .5 pounds. The length of the production run heavily influences the cost of the individual item because the tooling cost must be amortized over the entire run. In these small items tooling costs have ranged from a low of 10 percent for a 10,000 piece run to a high of 90 percent for a 200 unit run. Figure 2 shows some of the unique long baluster castings. The lengths go up to 49 inches and weights range from 3 pounds to 5 pounds. Tooling charges have varied from 3 percent to 50 percent of the total project cost. The 3 percent tooling charge was a result of the fabricator providing a dimensionally correct master pattern for a large, 3,100 piece production run.

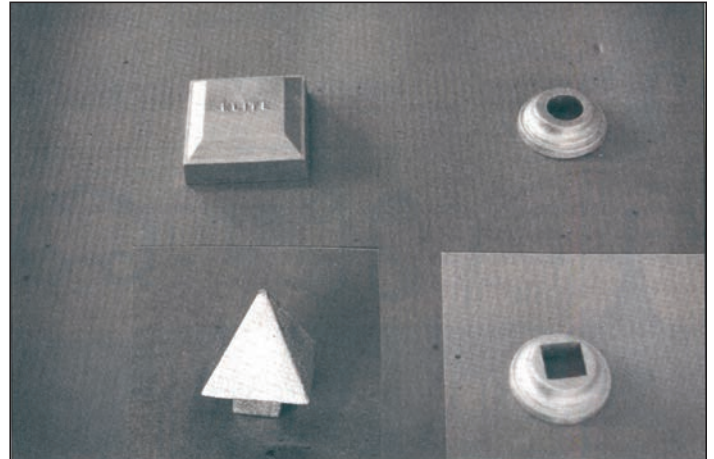

FIGURE 1 shows that even the smallest elements can be custom produced

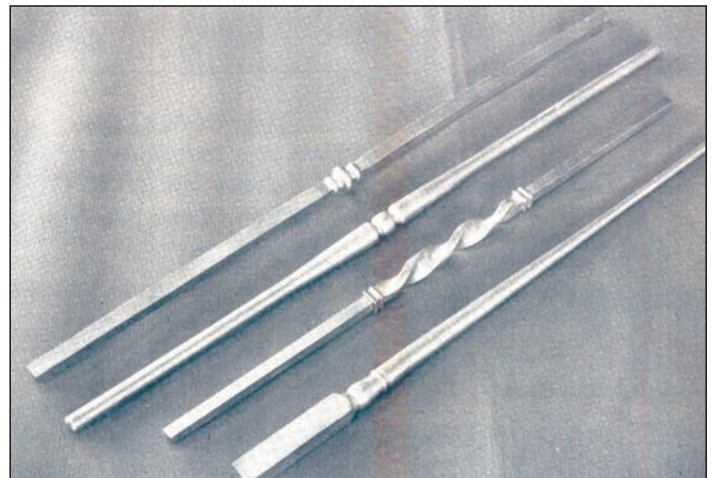

FIGURE 2 illustrates various long baluster castings

The items in figures 3 and 4 are mid-size castings with weights of 5 pounds to 20 pounds,. The tooling charges were 5 percent to 8 percent of the total project. The low tooling charges are again related to the high production run of the Hawaiian hotel pineapple plaque in figure 4 and the simplicity of the contemporary plaque in figure 3. In both of these cases the foundry was provided with an engineering drawing. The wood carver used the drawings to provide an





FIGURE 3 (top) depicts a mid-sized casting. FIGURE 4 (below) shows a pineapple used in a Hawaiian hotel project. Because the run was large, tooling cost per unit was low.

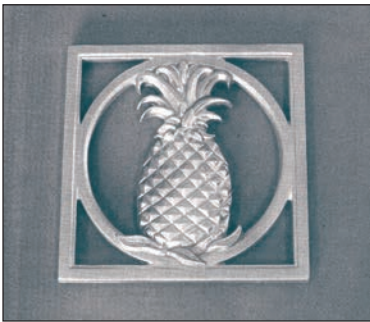

oversized dimensionally correct master pattern before the match plate maker created the production tooling.

The picture frame shown in figure 5 is 44 inches by 54 inches and weighs 42 pounds. The tooling charges are only 10 percent on this total project cost because the customer provided a master pattern that was single face and had the correct dimensions, drafts, smoothness, and tolerance.

The sea shell shown in figure 6 and figure 7 first came to the foundry as the 4-inch plaster minia-

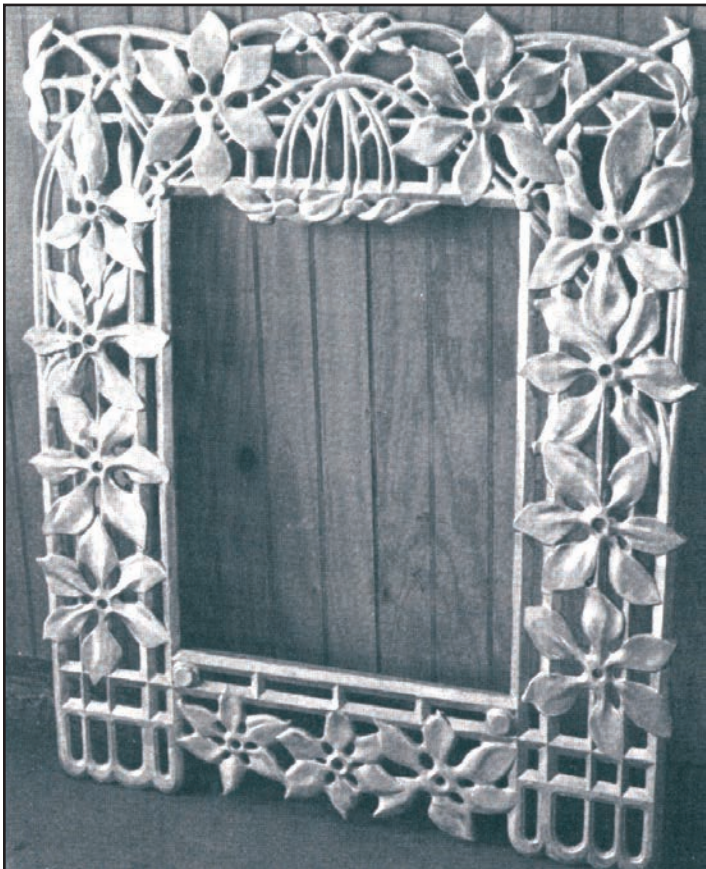

FIGURE 5 is an elaborate picture frame.

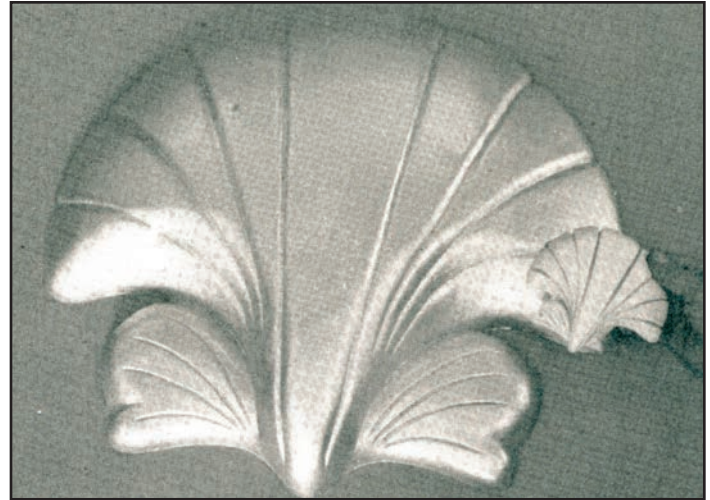

FIGURE 6 shows the plaster miniature and the final product.



FIGURE 7 shows the complete shell, which was used in a beach front development in Florida

ture shown in figure 6. The wood carver used the plaster miniature to extrapolate the size to a 2 foot by 2 foot pattern and a 4 foot by 4 foot pattern. The final 2 foot casting weighed 50 pounds (figure 6) and the 4 foot casting weighed 250 pounds. The unit is shown here on location at a Florida bay front development (figure 7).

Another option in the quest for uniqueness and originality is to modify existing patterns. Figure 8 shows a common ornamental aluminum bench end customized to accept varying logos and symbols. Typically adjustments can be made by adding to (epoxy) or taking away (machining) existing patterns. Tooling charges for this approach are commonly on the low side because the starting master pattern is already available as a sample of the full size original casting. The concept of adding symbols or letters to existing patterns can give a fabricator a chance to sell a common theme to developers of malls, townhouses, or



parks. In this way, trash containers, park benches, tables, tree grates, and entry areas can easily have a common logo or symbol.

Table I is a summary of the technical data for the items pictured in this article. Each of these aluminum castings started as an original idea and was the creation of a homeowner, architect, or fabricator. In all cases the foundry's job was to help the fabricator implement each custom project to the cost-aesthetic satisfaction of the end user.

An earlier article I wrote in the May-June 1987 Fabricator discusses the technical aspects of "custom-designed aluminum casting patterns." If you would like a reprint of the article, please contact Alloy Casting Co.



*Alloy Casting Co. has been a nationwide member of NOMMA since 1974.*

Fig.	Item	Size (in.)	Wt. (lbs.)	Single/ Double Face	Prod. Run Pieces	%Tool Cost
1	3" Fence Top	3x3x1	.25	DF	10,000	10
1	Round Collar	2 dia. x 1	.20	DF	200	90
1	Pyramid Spear	1x1x2	.20	DF	400	56
1	Square Collar	2 dia. x 1	.2	DF	200	90
2	49" Sq.	1x1x49	4.5	DF	240	50
2	49" Rd.	1x1x49	4.5	DF	240	50
2	Twist	1x1x42	2.75	DF	3,100	3
2	39" Sq. Rd.	1x1x39	3.5	DF	248	30
3	Plaque	16x16x2	19	SF	171	5
4	Pineapple	11x11x1	4.5	DF	2,600	8
5	Picture Frame	44x54x1	42	SF	600	10
6	2' Sea Shell	24x24x3	50	SF	6	70
7	4' Sea Shell	48x48x2	250	DF	4	50
8	Bench End	26x30x1	19	DF	1400	5

Source: Alloy Casting Co.

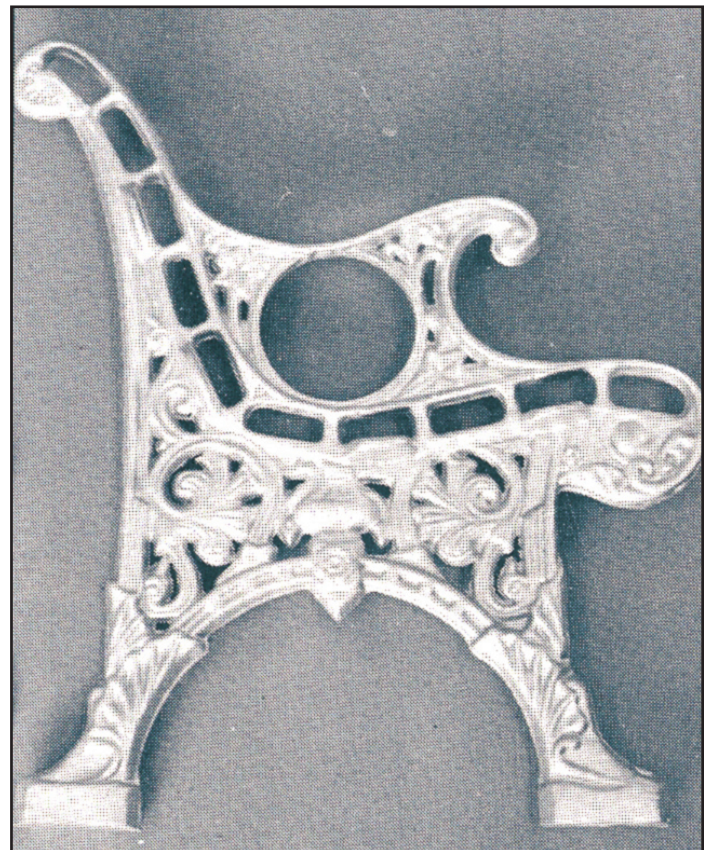

FIGURE 8: A common bench end.

# Custom Castings

After your drawings are complete, a foundry specializing in custom work can do the rest.

By Jon P. McGraw  
Alloy Casting Co.

This article originally printed in the 1994 November-December issue of Fabricator Magazine, an official publication of the National Ornamental & Miscellaneous Metals Association.

Once a fabricator provides a dimensional sketch for a custom casting much of the work is already done. From that point the foundry can provide a quote for a turnkey program that includes creating the master pattern, fabricating the tooling, and manufacturing the final product. The only part that should concern the fabricator is the creative concept and creating the sketch.

Like most custom projects, creating the sketch is the easy part. Selling, fabricating, and installing the job are always more involved.

One of the most encompassing projects that Alloy Casting has completed was a custom project for a blacksmith shop in West Palm Beach, Fla. The program included five custom castings of various sizes.

The owner of a Miami Beach, Fla. home was renovating a mansion to its original 1920s design. The source document for the design was a 1920s newspaper article containing a photograph of the house's original exterior. The newspaper photograph was studied and the ornamental iron work was redrawn to a full-scale drawing, which included three of the five custom castings [Figure 1]. The castings were to be used on the exterior of the house as a window dressing and security bars, and in the interior of the house as a room divider.

The sketches were submitted to Alloy Casting for a quote. The quote was for a turnkey project that included five original wood patterns and carvings,

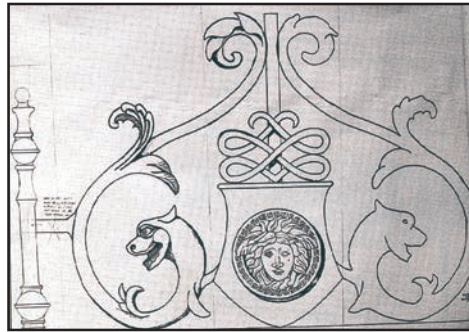

FIGURE 1: The work begins when the dimensional drawing are submitted to the foundry



FIGURE 2: The tooling is made for the face and dragon.

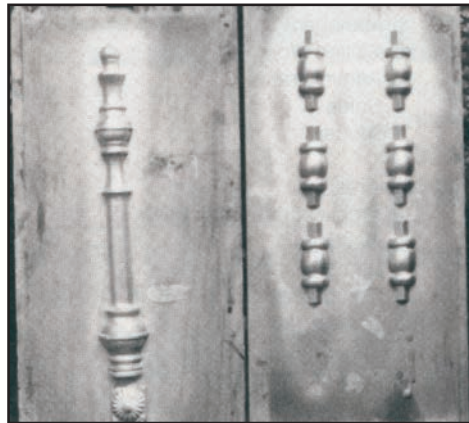

FIGURE 3: These parts will become double faced castings

four pattern boards, eight sets of castings, one 5/8 inch square core box, and a match plate. A match plate is a piece of production tooling that has the design of the casting embedded into it. When the foundry's sand is pressed against the design an imprint is left in the sand. It is this imprint that gives the aluminum casting its artistic shape. The core box enables the foundry to make and bake hard sand pieces. These hard sand pieces (called "cores") are then placed in the mold to block out areas of the casting where horizontal holes are needed.

The wood-carver began the project by carving the plaque face and the carved dragons. The full-sized drawing enabled the woodcarver to carve with confidence knowing that there would be no pattern modifications. The master patterns for the round collar (5/8 inch square hole) was created by a pattern maker and given to a match plate fabricator to make the production tooling.

The first phase of the project included only eight sets of castings. With such a small number of castings, four of the five original master patterns were mounted directly on wooden boards to save tooling expenses. Because the dragon faced both left and right, it was tooled to be double-faced. This allowed the same dragon to be used for both left and right applications. The collars and balusters were also double-faced. The face plaque was constructed on a single face pattern board in order to save carving duplication and expense. During the second phase



of the project, two single face plaques were placed back-to-back to create a two-sided design.

Figure 2 shows the tooling that evolved from the original carvings. The dragon is double faced and the sun faced plaque is flat black/ Figure 3 shows the tall baluster and the round collars that were lathe turned and mounted to wood pattern boards to provide a double face casting. Figure 4 shows the

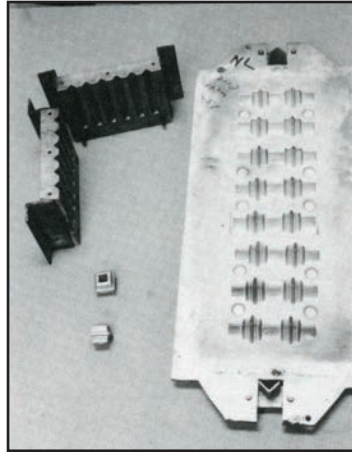

FIGURE 4: These collars are shown along there match plate and core box.

square collar, its match plate, and the 5/8 inch core box. The square core print on the tooling enabled a 5/8 inch sand core to be cast into the casting. When the core was removed, the result was a 5/8 inch square hole. The collar could then be slipped on to a 5/8 inch square bar. Figure 5 shows the castings arranged per the original sketch and Figure 6 shows the actual installation on the Miami Beach home.

A custom project for one item typically takes from start of master pattern work to prototype casting about four to six weeks. The exact time depends on the intricacy of the master pattern carving. In the Miami Beach project, it took seven weeks to complete the five original casting designs.

A foundry is organized to handle custom projects. Wood carvers and pattern makers are trained to provide sufficient drafts to eliminate undercuts and to compensate for metal shrinkage/ Foundries that handle all stages of custom casting production in-house, such as Alloy Casting, insure high quality tooling and prompt deliveries. Figure 6 shows the wood-carver working on a new pattern, while figure 7 shows Doug Thomas [left] examining the master with Juan Acosta, the match plate maker.

Most projects received by Alloy Casting are initiated by a fabricator with a sketch. When a sketch is used, the foundry quotes from this drawing after acceptance. The foundry then handles the project on a turnkey basis from master pattern through tooling fabrications, to final castings.

*This article is the third in a series on custom castings. Earlier articles covered technical details (May/June 1987) and economics of master patterns and tooling (November/December 1992). Alloy Casting Co. has been a NOMMA nationwide supplier member since 1974.*

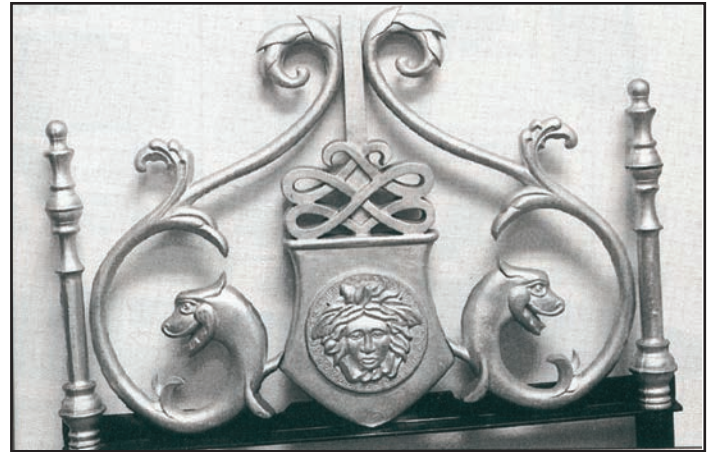

FIGURE 5: The castings are arranged per the original sketch.



FIGURE 6: The final product is installed in Miami Beach.



FIGURE 7: The wood carver creates a new master pattern. A good pattern design will compensate for metal shrinkage.





FIGURE 8: The carver and match plate maker examine a master.

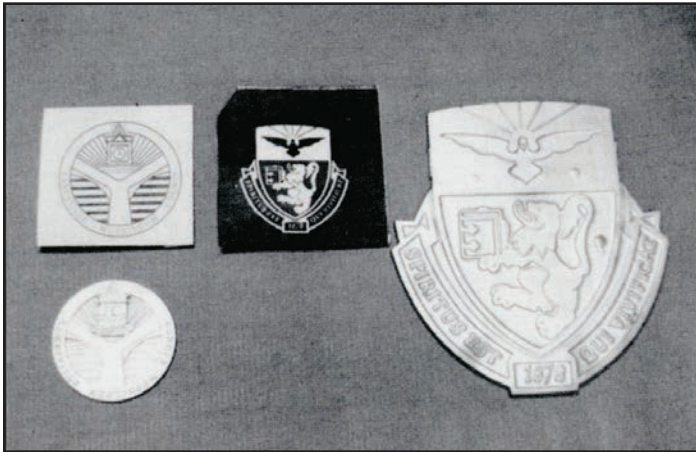

FIGURE 9: Both of these plaques are shown with their original sketches. The casting at the left is a full sized drawing for a bench end insert. At right, a 40 percent scale drawing was carved to actual size by the wood carver.

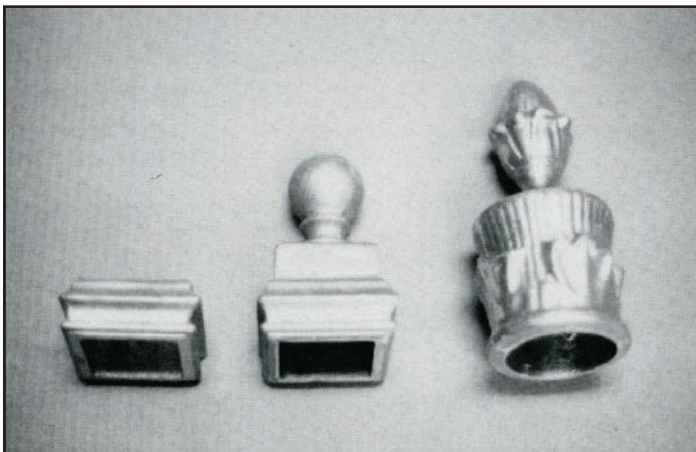

FIGURE 10: These two types of tops were created from two separate castings. The combination of two individual parts into one casting reduced fabrication costs. The item on the left is shown with matching floor flange. The left ball top is a combination decorative flange and a standard two inch ball top. The casting on the right combines a crown and a two-piece collar to form a single piece top.

# Using Aluminum Castings For Restoration

When ordering custom castings for restoration projects, different quality levels are available.

By Jon P. McGraw - Alloy Casting Co.

This article originally printed in the 1998 September-October issue of Fabricator Magazine, an official publication of the National Ornamental & Miscellaneous Metals Association.

**C**ustom castings are often requested during renovation and restoration projects. Often, new castings must be reproduced from old pieces taken from the job site, or even a drawing, old photo, or faded newspaper clippings. On a small scale these projects can be a homeowner needing 2-3 fence panels to repair a fence, or on a large scale the project can be a government agency restoring a turn-of-the-century post office.

Because of the age of the castings being reproduced, almost all of the designs are originals made in cast iron. The aluminum replacements are easily accepted by the fabricator and architects. Aluminum is more forgiving than cast iron. It is easily drilled and fabricated, lighter in weight, rust free, and simple to weld. If the project involves attaching aluminum castings to a steel frame, a steel clip, bolt, or stud can be placed in the aluminum casting during forming. This steel insert can then be welded to the steel framing.

There are some quality constraints with a restoration project. If the job calls for only a few new castings, the tooling charges may easily outweigh the cost of the individ-

ual pieces. On a small project, for example, our foundry can reproduce directly from the older casting sample by forming the mold around the "loose" sample. In this case the detail in the new piece will be no better than the detail in the old casting, and in many cases worse. By producing the new casting loose there is no tooling to hold the sample rigid in the production equipment. This lack of rigidity causes floating, which sometimes reduces the quality. There is also a loss of crispness in the detail and an accumulation of defects. Think of this method as using a photocopier, where you must make a copy of a copy. Each time a "copy of a copy" is made, the defects accumulate. As details become blurry and blotches occur, some of these defects can be eliminated by using an old sample to make new tooling or by re-detailing to create an epoxy look-a-like.

The reproduced castings will also be 2 percent smaller than the original. When the 2 percent shrinkage is a problem, the issue can be circumvented by lengthening the sample casting or by adding epoxy where needed.

A typical renovation project, where no samples were available, is shown in Figures 1 and 2. The figures

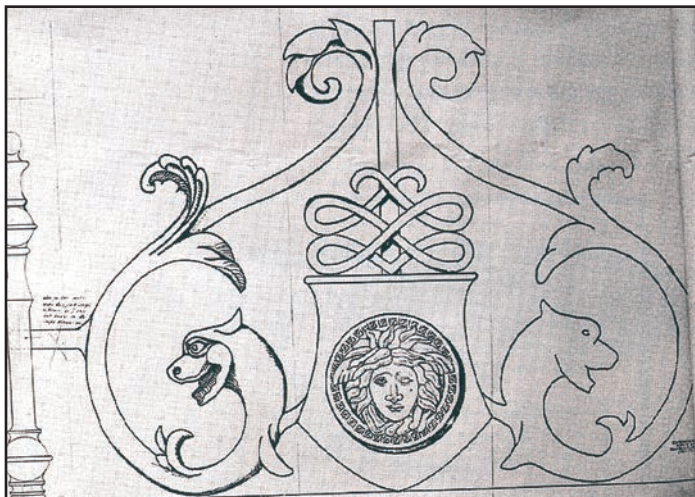

FIGURE 1: This reproduction job started out with a full scale drawing of a three piece window crest

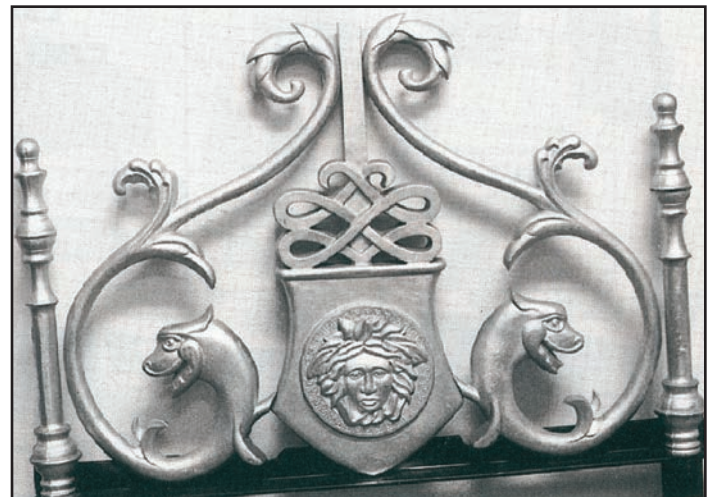

FIGURE 2: The drawing comes to life in a stunning aluminum casting



are of a window cresting for the renovation of a 1920s house in Miami, Fla. All ironwork on the house had been removed and destroyed by a succession of owners. But the new owner had a faded 1920s newspaper article and photo that depicted the house when new. This photo was used to make the full scale drawing in Figure 1, and reproduced as three new wood-carvings. The resulting castings are shown in Figure 2. It is a remarkable reproduction.

Figure 3 shows two cast iron panels from a Pennsylvania bridge renovation project where samples were available. The sample panels were cleaned up, epoxy was added to lengthen the required 2 percent, and new match plate tooling was fabricated. A 100 units of each design were required. Figure 4 is an example of the original bridge railing.

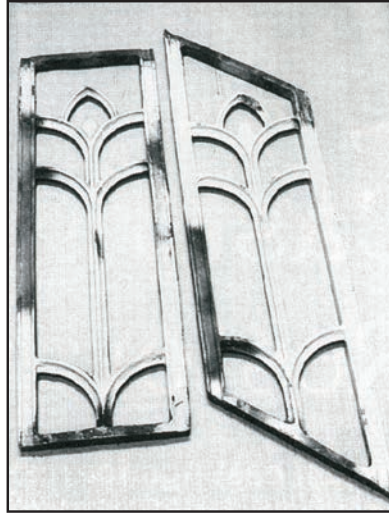

FIGURE 3: These two cast iron panels were actually removed from the job site.



FIGURE 4: The original panels, which adorn a bridge in Pennsylvania.

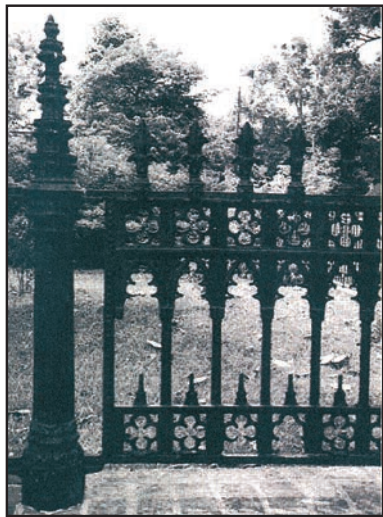

FIGURE 5: (left) The original fence, which adorned a home in Mississippi. FIGURE 6: The fence panel is broken into separate components

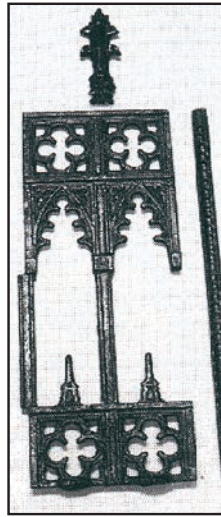

Figure 5 shows broken fence panels of an older home in Mississippi. Figure 6 is the fence broken into its three individual components. The samples came to us with many layers of paint and years of accumulated rust and debris. Twenty-four interlocking panels, 48 finials with a 7/8 square slot, and 6 textured end pieces were required for this project. The panels were for restoration of broken panels on the

existing iron fence and a 2 section expansion of new fence. The samples were sandblasted, and new match plate double face tooling was fabricated. There are similar fence panels in existence, but none fit the home owners' exact requirements. In this project it was verified several times with the home owner that the new casting would be aluminum, and her local installer could handle the fabrication of the two dissimilar metals.

The first casting on the left in Figure 7 shows an 8 inch cast iron stove leg with a hollow back. The other three castings are aluminum legs that have been cast loose, without the benefit of permanent tooling. Only one leg was required. But because reproducing in this manner sometimes gives questionable quality, we cast three legs and picked the best one to ship. Around the edges of the two right most castings, the rough edges can be seen. The selected casting, second from left, also looked this way, but it was extensively cleaned with chipping hammers, grinders, and files.

The two cast iron finials in Figure 8 were cast in Ohio during the late 1800s for a mansion in Pasgacoula, Miss. A current source for matching finials could not be found. Alloy Casting was sent a sample of each finial. An epoxy mold was made, and the resulting finial was re detailed and mounted to a pattern board. To provide a compatible welding point between the aluminum finials and the steel frame, we provided a 2 inch long, 3/8 inch diameter smooth steel rod that was cast into the aluminum. The rod protruded out 1 inch. The fabricator's job entailed redoing old broken fence sections and a driveway expansion. Over

1,000 finials were required.

Over the years Alloy Casting has done many restoration projects. Each project was unique. We once did aluminum pieces for a large scrolled iron chandelier with missing sections. It was fortunate that the lamp was not welded as it allowed the iron and aluminum replacement pieces to be interlaced and bolted together. The chandelier (no photos available) now sits in a restored mansion in Ohio with few people knowing its blend of old and new technology.

In 1992 the Hill Country Courthouse in Texas was gutted by fire. Two years later we were requested by a local Waco, Texas, fabricator to reproduce the window walk roof cresting for the courthouse. The source material for the product included old photos, old drawings, and a partial piece of heavily burned cast iron. There were five pieces to the project that entailed a combination of four wooden pattern boards and one aluminum match plate. The exterior of the building was the first phase in the renovating project, and the new aluminum roof crestings were visually equal to the old cast iron pieces.

The diversity of projects that fall under the renovation and restoration category is endless. Every project from home owner's fencing to bridges, to building facings to theater stairs, to roof cresting, has been completed with aluminum castings. We have even had inquiries to do aluminum castings for antique cars. Anything is possible.

The key items to consider for reproduction are the quality of the sample item submitted as a pattern and the trade off between the number of casting required and the amount of tooling investment needed to maintain quality.



*Alloy Casting has been a NOMMA member since 1974. This article is the fifth in an ongoing series on custom castings. For a complete collection, call Alloy Casting at 800-527-1318.*

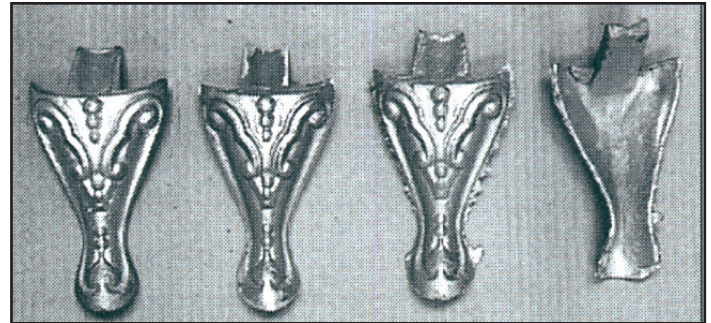

*FIGURE 7: The stove leg casting on the left is cast iron with a hollow back. Although only one duplicate was needed, three were poured to allow for some selection. The one chosen for shipping is the part second from left, shown after cleanup.*



*FIGURE 8: These two iron finials were originally cast in Ohio during the late 1800's. To reproduce these, an epoxy mold was made, and the resulting finial was re detailed.*



# Choosing The Right Alloy For The Right Custom Casting

The properties of aluminum alloys vary greatly. When specifying a custom casting, it's important to select the best alloy for your particular need.

By Jon P. McGraw  
Alloy Casting Co.

This article originally printed in the 1997 September-October issue of Fabricator Magazine, an official publication of the National Ornamental & Miscellaneous Metals Association.

**W**hen choosing the alloy for an aluminum casting, it's important to select a type that provides the best detail and weldability, while at the same time having good foundry characteristics. A good aluminum alloy should contain silicon for high detail retention and flowability, and it should not contain elements detrimental to weldability, such as nickel. Nickel is harmful because of its high melting temperature.

Other properties to consider when choosing an alloy are strength, good corrosion resistance, and bendability. The projects described in this article show the advantages of matching the best alloy for a particular need. Table 1 summarizes the chemical compositions described in these scenarios.

## Castings That Bend

Fabricators in the trade desire to make jobs look good. And, it sometimes helps if they also look unusual. One way to achieve this combination is for the castings to have the ability to bend into unusual shapes. Most casting have metal combinations that are stiff and difficult to bend, but it is possible to find highly bendable alloys.

On the other hand, the casting in Figure 2 has a more consistent cross section of 3/8 inches by 1 1/4 inches, and we were able to achieve a much larger bend of 10 inches in a 27 inch length.

The most dramatic bends have been obtained in a leaf design, 4-1/2 inches by 40 inches, with a consistent 3/16 inch thickness., shown in Figure 3. These leaves were specially designed and a special alloy was chosen to provide maximum bending ability.

Good bending results can be obtained at room temperatures, and you can feel the casting stiffen as the hardening takes place. The twisting and compound bends of the leaves were obtained by heating the casting, bending, and reheating as necessary. It is a trial and error process, but it's possible to make some very dramatic shapes.



FIGURE 1: This rose panel can be bent 3 inches without cracking.

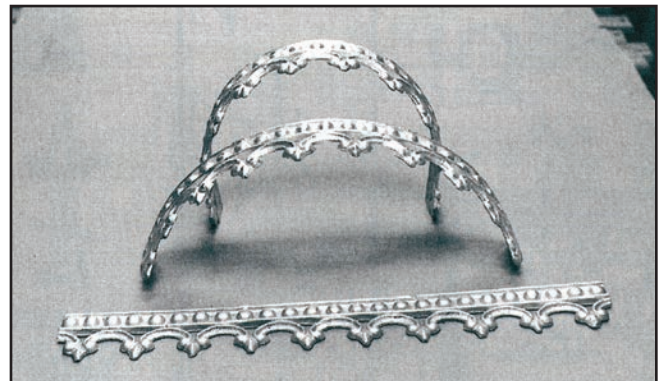

FIGURE 2: A more consistent cross section allows this trim frieze to bend 10 inches.

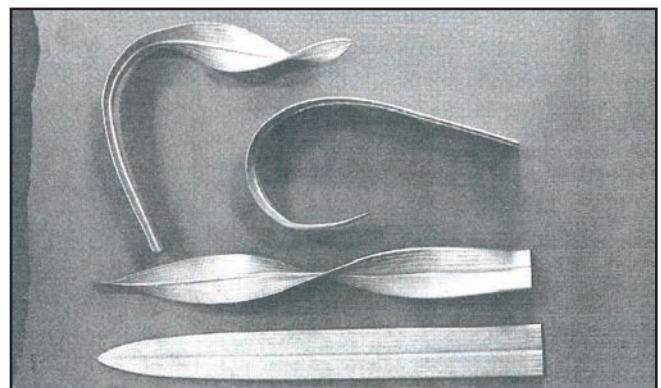

FIGURE 3: Maximum bending is obtained on these leaves. The bending was done with the assistance of heat.

## Weldability

Most aluminum castings provided by foundries to the ornamental trade are provided in the 'as cast' condition (temper F). These castings are readily weldable and no special cautions are necessary.

The casting alloy is normally in the 300 series, which provides good castability for the foundry and good detail retention and weldability for the fabricator.

In those cases where there is a special application for high strength and/or corrosion resistance, extra care is necessary in selecting a welding rod. It's also important to remember that a casting given a special heat treatment cannot be welded without destroying the special treatment in the area affected by the weld. When welding, the fusion that occurs changes the microstructure of the metal and transforms the area back to an "as cast" condition.

## Corrosion Resistance

Alloys that have good corrosion resistance show poor casting characteristics for the foundry and poor weldability to the fabricator. Figure 4 is a handrail panel that was made from alloy 514 (4 percent magnesium) and was used in a sea coast application. Alloy 514 exhibits good corrosion resistance properties.

On the other hand, alloy 535 (7 percent magnesium) shows a higher strength and a superior corrosion resistance because of its higher magnesium and lower and tighter specifications on trace metals. Alloy 514 was specified for the job, but for the same money 535 could have been used. This is a situation where the specifier did not take full advantage of available options. These two alloys are from the same family as the sheet and plate used for marine applications.

Those metals that strengthen aluminum the most, like copper and zinc, are the most detrimental to the corrosion resistance of aluminum.

## Strength/Heat Treatment

Those alloys exhibiting high strength are normally poor in other characteristics. Alloy 713 (7 percent zinc, 1 percent copper) was chosen for the chair leg piece shown in Figure 5. Alloy 713 has high strength in the "as cast" temper and needs no heat treatment for maximum properties. The alloy, however, pours like molasses, has high shrinkage, and tends to lose detail. Fortunately, the rectangular leg cross section of 5/8 inches by 1 inch is plain and simple and showed shrinkage only in the hidden back side of the legs.

Another alloy commonly used in the "as cast" temper is alloy 319 (7 percent silicon and 3 percent copper). In

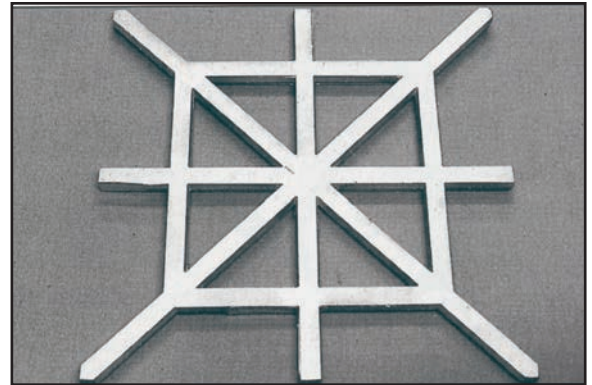

FIGURE 4: This handrail panel uses corrosion resistant alloy 514, which contains 4% magnesium. The panel was created for a sea coast application.



FIGURE 5: The emphasis on this chair leg casting is strength, thus alloy 713 was used. This alloy does not require heat treatment.

this alloy, silicon has replaced the zinc and imparted more flowability and detail retention. The strength loss through the elimination of the zinc is partially compensated by an increase in copper. Figure 6 shows some castings that have been cast in alloy 319 for good machinability. The holed clutch housing is designed to break under certain conditions and alloy 319 imparts a consistent microstructure for that predictable breaking.

Alloy 356 (7 percent silicon, 1/4 percent magnesium) is the aluminum foundryman's all purpose workhorse. It has good detail retention and pours well. It is the most commonly used alloy and is specified in either the 'as cast' or heat treated condition. The 'as cast' condition strength levels of 19,000 p.s.i.(pounds per square inch) can be raised 34,000 p.s.i in the T-6 temper. T-6 temper is soaking at 1,000 degrees F for 12 hours followed by an aging treatment of 310 degrees F for 3 to 5 hours. This strengthening occurs because of a hardening process caused by the 1/4 percent magnesium.



The heat treatment has a powerful influence on properties but can increase the casting cost by 20 to 40 percent.

Figure 7 shows some industrial tire spreaders that were cast in alloy 356 and tempered to T-6. The extra strength was a requirement. Because the heat treatment improves the metal's 'as cast' microstructure, any subsequent welding destroys the heat treatment's benefits.

Because of its reasonable cost and high strength, alloy 713 would always be chosen if strength and cost were the only criteria, but because of other needs like corrosion resistance, weldability, detail retention and castability, alloy 356 and the other alloys are more frequently specified.

### Polishing

Some alloys polish better than others. The high strength alloy 713 has a good luster, but for my personal preference and use, I have chosen alloy 514 (4 percent magnesium) to impart a beautiful polish and high luster to the seashell cocktail table in Figure 8. The seashell and legs of this table are now four years old and have the same shine as they did when they were first professionally polished.

### Summary

The job requirements for most ornamental work can be handled with decorative castings made from common everyday alloys. But for that special job requiring a unique set of physical characteristics, it is good to know what other alloys are available that can provide those unique properties. Strength, corrosion resistance, weldability, luster and benability can all be modified with an alloy that gives the right blend of unique properties.



This article is part of an ongoing series on custom castings. Alloy Casting has been a NOMMA member since 1974.

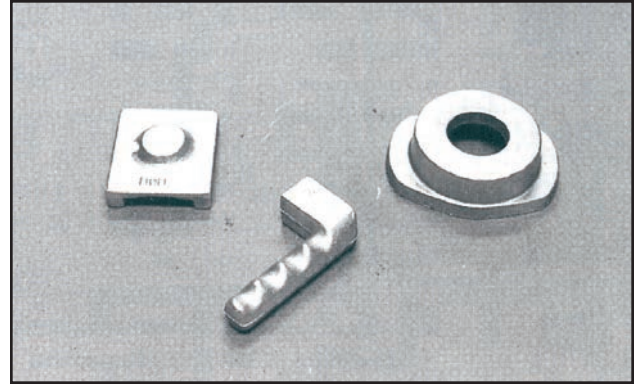

FIGURE 6: These parts were cast in alloy 319 to provide the best machining characteristics.

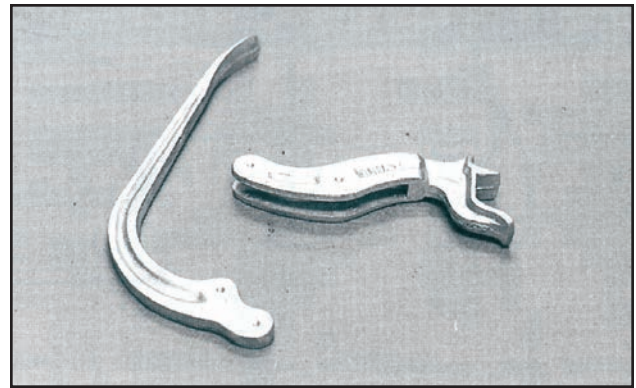

FIGURE 7: A heat treatment was applied to these industrial parts, which were cast in alloy 356 and tempered to T-6



FIGURE 8: Some alloys are better suited for polishing. This four-year-old table was made with alloy 514. The aluminum seashell and legs show no signs of tarnishing.

Table 1: Chemical Composition (%)					
Alloy	Silicon	Iron	Copper	Mag.	Zinc
Bendable	0.50	0.50	0.50	0.50	0.50
319	6.00	1.00	3.00	0.10	1.00
356	7.00	0.60	0.25	0.25	0.25
514	0.35	0.50	0.15	4.00	0.15
535	0.15	0.15	0.05	7.00	-
713	0.25	1.10	0.70	0.40	7.00

Different metal compositions greatly influence an alloy's properties.

# Prepare to Powder Coat and Put Off the White Stuff

Six preliminary steps can help fight off long  
And short-term corrosion.

By Jon P. McGraw  
Alloy Casting Co.

This article originally printed in the 2002 July-August issue of Fabricator Magazine, an official publication of the National Ornamental & Miscellaneous Metals Association.

**P**owder coating aluminum castings can sometimes be a problem. Immediate problems appear when the powder coat bubbles because of gas evolution from the casting during the heating cycle. Long-term problems happen when white corrosion develops under the coating, and flaking and peeling starts. Even though powder coating is a sophisticated process, these two problems do occur. Fighting off their occurrence is possible by taking correct preliminary steps. Preventative action can mean the use of a better base metal, preheating to degas the casting, extensive chemical cleaning, proper acidic etching rinsing with deionized water, and adequate powder curing. A lack of attention to any one of these steps can mean a rough surface and/or a coating that eventually will flake.

## One: Use a Better Base Metal

When most aluminum castings are placed in a seacoast environment they demonstrate white corrosion. This corrosion is caused by salt air penetrating the coating and allowing a galvanic battery action between the aluminum and the dissimilar metals in the aluminum. These dissimilar metals are mainly copper

### FYI IN THIS ARTICLE . . .

- An industry supplier of aluminum castings and aluminum hardware lists six ways to avoid two problems that occur when powder coating aluminum
- Short term problem, like bubbling, result from gas evolution during the heat cycle.
- Long term problems, like flaking and peeling, stem from white corrosion setting in between the coating and the base metal.

For more info call Jon McGraw at (800) 527-1318

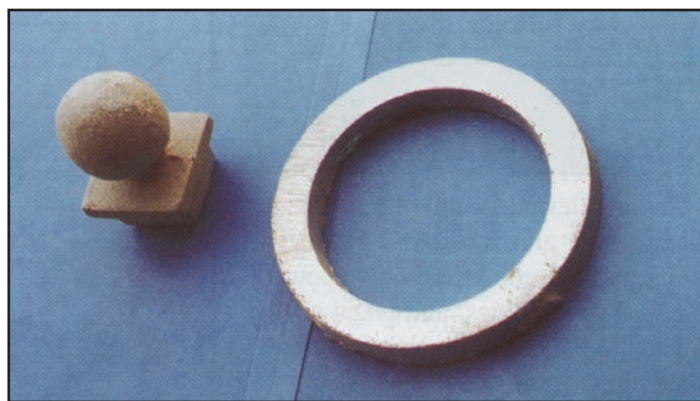

*In the above example, the ball cap with the dull white corrosion was made with a standard aluminum casting alloy. The ring shown was made with a marine-grade alloy and shows no corrosion. It has retained its metallic shiny surface. Both samples were placed together in a chlorine corrosive environment.*

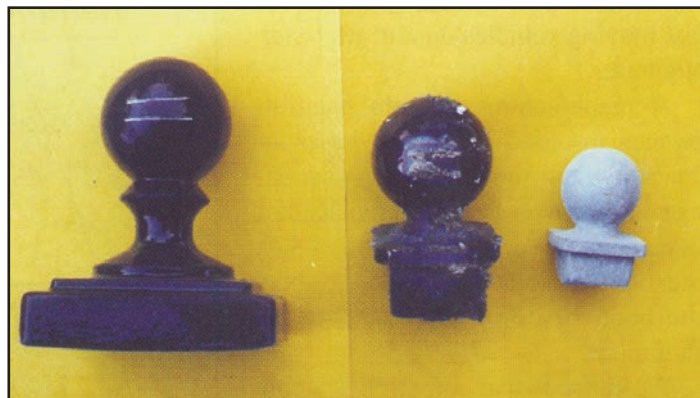

*These samples were placed in a severe chlorine atmosphere to replicate a corrosive environment. The sample on the right is a typical casting showing a white-chalky surface. The center powder coated sample shows corrosion that has penetrated from the inside out of a typical casting. The marine-grade ball aluminum cap on the left shows no corrosion. Even with two saw cuts that were put through the coating and into the ball prior to the corrosive environment, the marine-grade metal did not corrode under the powder coat nor did the coating flake off*





*Left: Dissimilar metals in almost any form can cause severe corrosion. The green area shows severe galvanic corrosion caused by a marine-grade aluminum ball cap attached to a stainless steel bolt.*

*Right: This ball plug was made with a standard casting alloy, degassed and double coated. The ball exhibits few bubbles but even the double powder coating did not prevent corrosion from penetrating where the coating had been thinly applied. Green speckles show corrosion penetration.*



and zinc. The cause of the problem can be eliminated by using a marine-grade aluminum alloy having magnesium as a major component. Even under the most severe conditions, the marine-grade alloy stays shiny and coherent under the powder coat and eliminates white corrosion.

## **Two: Degas the Metal**

The second step for excellent powder coating of aluminum castings is to run a preheat cycle to degas the metal. The preheating expels the contained hydrogen that was entrapped as a natural result of the casting process. Aluminum sand mold castings are made in a mixture of sand, clay and approximately 4 percent water. The impact of the molten aluminum on the damp sand creates steam of which a portion is absorbed into the casting as hydrogen. During the powder coat heating cycle, the hydrogen is expelled and shows up as a bubbly surface. This problem can be eliminated by first using a preheat cycle that is 50% to 100% higher than the normal powder curing temperature and for a time cycle 30 to 100 percent as long as the powder curing time. A good degassing cycle will eliminate unsightly bubbles.

The proper selection of a marine-grade alloy and degassing can greatly reduce problems with powder coating on aluminum castings. But even with those actions, there are two more essential steps that need to be taken: good cleaning and good surface etching.

## **Three and Four: Cleaning and Etching**

Good cleaning entails alkaline decontaminating to remove organic oils, waxes and lubricants, and acidic cleaners to remove inorganic rust, scale, weld-

ing smut and to etch the surface. Contaminates and moisture left on the surface will detract from powder adhesion and give a poor coating life.

## **Five: Deionized Water Rinsing**

After acidic etching the surface must be rinsed to remove contaminants and rinsed sufficiently to give a “water breakfree” cascade off the surface. Deionized water is the best media for this procedure.

After rinsing, the casting should be dried and free of powder or streaking on the surface. A powdery film indicates poor rinsing or old, heavily contaminated cleaning fluids.

## **Six: Curing**

Proper curing of the powder coat is also critical for good longevity. A weak, soft coating will not stand up to the elements. As indicated above it takes several correct steps to enhance the life of powder coating. A misstep in any one can cause flaking.

I have seen castings on a gate application where the coating on cast aluminum spear finials was in excellent shape but only 24 inches lower on the same picket the cast aluminum collars were badly corroded with the powder coat flaking off. It was difficult to determine which of the many initial steps had been adequate for the finial but inadequate for the collar. Note the photographs on this page showing actual job applications where the powder coat process proved to be inadequate.

Other reports from the field suggest that imported aluminum castings exhibit much more out-gassing and corrosion than domestic castings. This is probably due to higher levels of dissimilar metals and

contaminates and lower quality foundry practices at foreign shops.

The important steps for powder coating are the same important steps for other coatings as well, be that fluoropolymers, wet paints, or hybrid combinations.

A good powder coating system is a sophisticated process. There are many sequential steps that must happen correctly in order to obtain good results. These detailed steps are highly technical and more than can be covered in this short article. So the next time you send a job with aluminum castings “out to be powder coated” and worry about the results, think of the many steps that are essential to providing a smooth, long lasting coating. Reduce those worries and insure good results by taking preventative action. Make sure the job is not returned.

---

---

---



*Below and right: White corrosion has deteriorated the powder coating on the floor flange below and on the metal rings of this cast iron gate.*

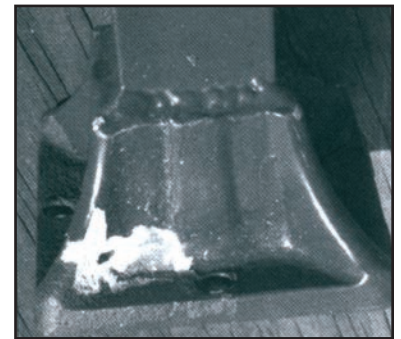



# The survey says, . . .



These spear points illustrate the coherent coating of marine grade castings in excellent condition after one year on the beach.

## “Marine grade castings!”

■ A pictorial survey of eight case studies suggests that using marine grade castings and a modified powder coating application to avoid degassing results in long lasting beautiful aluminum castings, even in harsh salt water environments.

*By Jon McGraw  
Alloy Casting Co. Inc.*

*There are many steps necessary* to providing a good, hard, coherent coating to aluminum castings. These steps include proper cleaning and rinsing, degassing, and proper curing of the coating. However, even if these steps are followed and the powder coater does the best possible job, sufficient evidence from on-site inspections and field reports suggests that another step is necessary on your part: using marine grade base material. The marine grade approach offers added pro-

tection that makes your job look better for a longer period of time. And that reduces call backs, which makes all of us happier.

The rapid flaking and peeling of coatings from aluminum castings in a severe weather environment or the normal long term slow deterioration in a mild environment can be resisted with the proper selection of marine grade base metal because marine grade aluminum castings resist corrosion and improve coating performance.

### For your information

**Poor finish:** Non-marine grade castings and sub-par powder coating application (page 30).

**Better finish:** Marine grade castings and sub-par powder coating application (page 32).

**Best finish:** Marine grade castings and good powder coating application including a modified degassing pre-bake cycle (page 34).

**Contact:** Jon McGraw, Alloy Casting Co. Inc., Ph: (800) 527-1318.



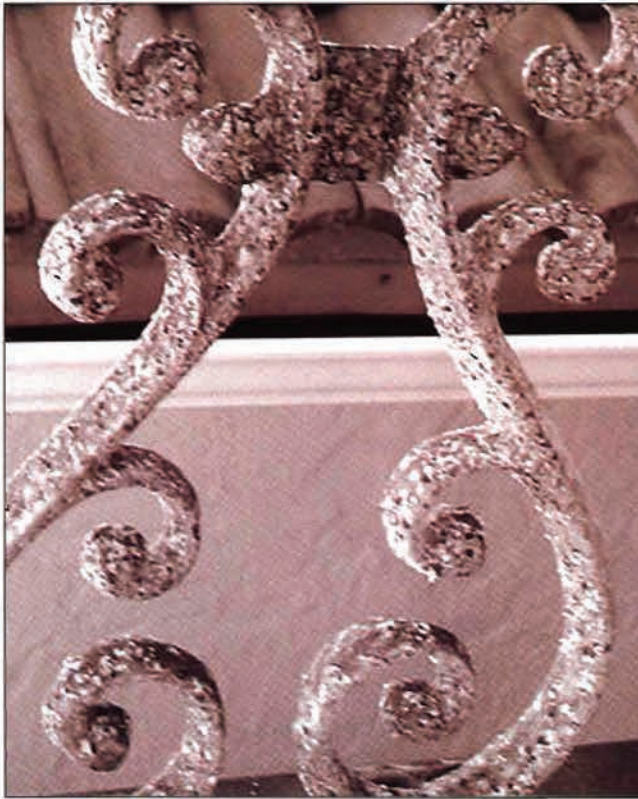

**This scroll casting is not marine grade. It shows severe white corrosion after only 18 months in its ocean environment in Sarasota, FL. No coating remains.**



**This 12-year-old aluminum furniture in Dallas, TX, is also not marine grade. Even though it is not in a harsh marine environment, its powder coat is peeling and corrosion appears.**

### **Corrosion on aluminum**

Flaking and peeling occur on regular aluminum because air penetrates through the coating and corrodes the base metal. The devastation of the coating can occur rapidly when the job site is next to the ocean. Or it can take a much longer period of time in a more temperate climate. Either way, however, the castings will eventually show signs of corrosion. The scroll casting pictured at the top of this page has been on the ocean only 18 months and shows



**This 2" ball cap is not marine grade. It shows chalk corrosion and flaking (starting at corners) after four years on the Indian River in Vero Beach, FL.**

almost complete disintegration; whereas the aluminum furniture (pictured below it, bottom of page 29) is located in the more moderate environment of Dallas, TX. In this less harsh environment the aluminum held off significant corrosion for 10 years. The furniture has now been in the weather 12 years.

### **Poor: Corrosion on non-marine grade castings with sub-par powder coating application**

Typical corrosion of non-marine aluminum castings is shown at left. The ball cap has been near the ocean for four years and shows the corrosion on the corner edges where only a thin layer of coating might have been applied. This edge with a thin coating enables the salt air to penetrate here first and begin the corrosion peeling action. The root cause of the white chalk aluminum corrosion is the residual amounts of copper that create a galvanic reaction with the aluminum base material.

### **Better: Corrosion on marine grade casting with poor powder coating application**

Even the use of virgin metal with the correct marine grade chemistry, however, cannot cure the faults of a poor coating application. Pictured at the top of page 32 is a handrail installed near the ocean in Palm Beach, FL. For eight years the castings have been directly exposed to the wind and spray of the ocean. However, they are still shiny and coherent. This shiny and coherent surface indicates no galvanic corrosion has occurred as the marine metal has successfully resisted the salt air. But because of the





**This flower panel in West Palm Beach, FL, shows flaking because of a poor coating job. But its marine grade castings are still shiny and coherent after eight years.**

poor powder coating application, the net effect is still a poor looking rail. Compare this picture at left with the non-marine grade aluminum castings that have been on the ocean only 18 months (top of page 29). Marine grade castings on the ocean eight years with no corrosion pictured at left show the value of the proper base metal. Again, however, even the marine grade metal could do nothing to improve the original poor powder coating.

**Best: Corrosion on marine grade castings with good coating application**

A recent on-site survey of many copper-free marine grade castings that have been on the ocean between one and 3½ years shows the excellent results of combining marine grade castings with good powder coating applications. Shown below and on page 34, the castings are coherent and show no signs of corrosion or flaking.

When I visited one fabricator in Jupiter, FL and asked to visit job sites that have had marine grade metal for



**This aluminum rail with marine grade aluminum cast collars also shows a coherent coating in excellent condition after three years on Florida's Intracoastal Waterway.**



This marine grade and well powder coated spear and ball cap located just 100 yards from the ocean is in excellent, coherent condition after 3 1/2 years.



This marine grade large, heavy seashell aluminum casting adorning an exterior fence located between the Intracoastal Waterway and the Atlantic ocean shows a coherent coating in excellent condition after two years.

several years, he said, "I don't know where they are. I only know I have had no call backs because of poor performance."

**Caution: Avoid out gassing during the powder coat cycle when using marine grade castings**

The above comment shows the overall value of using marine grade aluminum. However, the value of marine grade castings can be undermined if certain precautions are not taken to prevent out gassing during the powder coat cycle. The chemistry of the marine grade metal demands the foundry pour at a higher temperature into the sand molds. This higher temperature in contact with the moisture inherent in the sand causes more than a normal amount of steam. This moisture becomes trapped in the aluminum casting. During the heating and curing powder coat cycle, the moisture is pushed out of the casting and causes a bulky surface in the powder coat. For this reason, it is recommended that the powder coater operate a de-gassing step. This includes (1) running a pre-bake de-gassing cycle at 50–100 degrees higher than normal, and (2) running the pre-bake cycle at least 100 percent longer than the normal powder coat curing time. On heavier aluminum castings a much longer pre-bake cycle may be necessary. 🌐



# The aluminum advantage

**Fig. 1: Right, the cast iron piece, aluminum match plate, and the duplicated aluminum casting.**

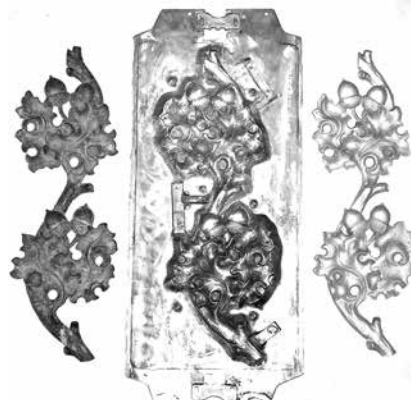

- As a replacement for original cast iron, architects often accept the more forgiving and easy-to-weld aluminum.

*By Jon McGraw*  
Alloy Casting Co. Inc.

**Replacement castings are often required** during renovation and restoration projects. Sometimes, these duplicate castings must be reproduced from old pieces taken from the job site. But, if no samples are available, drawings, old photos, or faded newspaper clippings might contain enough information for successful duplication.

On a small scale, these projects may involve a homeowner who needs two or three pieces to repair a fence, or, on a larger scale, a government agency that is restoring a turn-of-the-century post office.

Because of the age of the castings being reproduced, almost all of the old designs have been originally made in cast iron. However, fabricators and architects readily accept aluminum replacements for these cast iron pieces. Aluminum is more forgiv-

**Fig. 2: Above, these designs were fabricated "loose" to save on the cost of permanent tooling.**

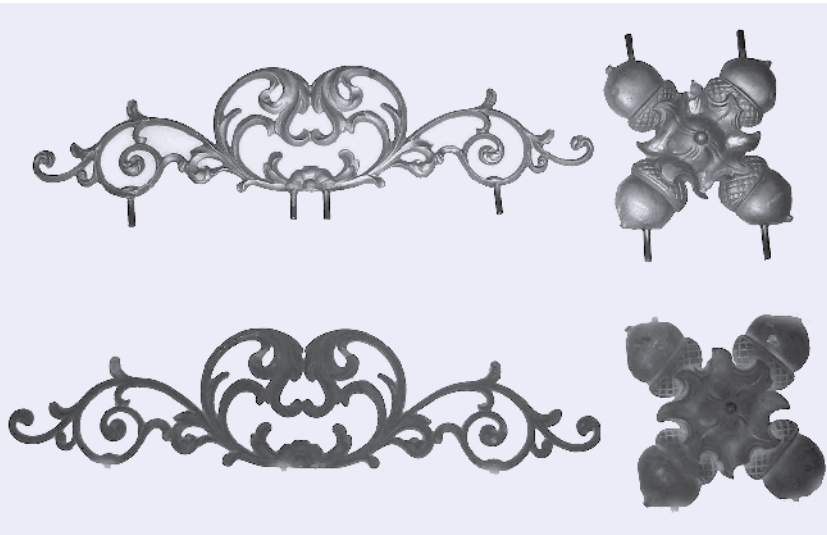

**Fig. 3: Right, the pattern board used for the large corner bracket.**



ing than cast iron. It is easily drilled and fabricated, lighter in weight, rust free, and simple to weld.

Moreover, if the project involves attaching aluminum castings to a steel frame, a steel clip, bolt, or stud can be placed in the aluminum casting during forming. This steel insert can then be welded to the steel framing.

Restoration projects usually have some economic constraints. If the job calls for only a few replacement castings, the tooling charges may be excessive for a small number of individual pieces. On these projects, our foundry reproduces directly from the older casting sample by forming a mold around the “loose” sample. By producing the new casting in a “loose” manner, tooling expense is unnecessary, but the higher labor cost of this approach makes for a higher per piece cost. We always try to achieve the lowest overall cost for each casting.

Working with John Graney, John Graney Metal Design, Sheffield, MA, a recent project of ours entailed castings originally made in the mid-1800s. Four different cast iron designs had been fabricated as a veranda onto a house originally built in 1806.

The project meant making aluminum replacement pieces based on the cast iron originals. A piece of the running oak top frieze was cleaned and used as a pattern sample to fabricate an aluminum match plate. The match plate captured all the many curves and see-through openings. The cast iron piece, the aluminum match plate, and the perfectly matched aluminum casting are shown in (Fig. 1).

Two other designs, the “X” oak and the scroll frieze required only 20 pieces each. Because the piece count was low, these two designs were fabricated “loose” to save the expense of permanent tooling (Fig. 2). Steel welding pins ( $\frac{3}{8}$  inch diameter) were cast into the two designs so they could be welded to the steel framework.

The last casting in the project, the large corner bracket, was reconfigured and set up on a wooden pattern board (Fig. 3).

The different approaches used on each of the four designs achieved the lowest cost for each casting.



**Four different cast iron designs had been fabricated as a veranda onto a house originally built in 1806. The project meant making aluminum replacement pieces based on the cast iron originals.**

### **A gazebo restoration**

We helped Frances Flaherty, Flaherty Iron Works, Alexandria, VA, on another mid-1800s historical project: the restoration of an eight-sided gazebo, circa 1860, at a Civil War Naval Hospital in the Richmond, VA, area.

Alloy Casting made the aluminum castings from the original cast iron pieces.

After casting, the surface was distressed to make them look old like those (See Fig. 4) of the original gazebo and (Fig. 5) for the reproduced aluminum castings.

The Civil War foundry craftsmen were skillful because we had much difficulty duplicating their workmanship with the small and tight hole structure of the original castings. Because there were only two big and two small castings needed, we did not make tooling but, again, ran the castings “loose.”

### **Duplicating hand rail posts**

Restoration of existing facilities where no samples are available can be achieved from a sketch or drawing. Alloy Casting, in conjunction with Pete Shaw, Shaw Mfg., Hilton Head, SC, and H. M. Kern Construction, Greensboro, NC, fabricated matching hand rails for the Almalce County courthouse in Graham, NC.

We duplicated aluminum rail posts from the original 1914 wood post. The project included an exterior handicap ramp with illuminated grip rail and a new interior stair well. The tooling for the post was fabricated from the sketches. (Fig. 6). The next photo (Fig. 7) shows the post pattern made from the sketches. All posts were cast in

## *For your information*



### **About the author**

Jon McGraw of Alloy Casting Co. Inc. regularly writes for *Fabricator*. His first article appeared in 1987.



### **About the company**

Alloy Castings, a NOMMA member, is a longtime industry supplier. The firm specializes in custom aluminum castings, both for decorative and functional needs.

### **CONTACT**

**Alloy Casting Co. Inc.**  
3900 South Peachtree Rd.  
Mesquite, TX 75180-2724  
972-286-2368  
972-557-4727 fax  
jonalloy@aol.com  
www.alloynet.com



corrosion resistant marine grade aluminum.

### Creating hand rail brackets

Sometimes an historical restoration is small and out of sight. Bruce Rienks, Evans Metal Products, Elkhart, IN, had a project at the old Palace Theater, South Bend, IN, originally built in 1921. Alloy Casting's role was duplicating seven sets of a unique two-piece handrail bracket (Fig. 8). These pieces were easily fabricated "loose".

The diversity of projects that fall under the concept of renovation and historical restoration is endless. Any project, from homes, theaters, gazebos, bridges, and roof cresting to even antique cars can be completed with aluminum castings. Final castings can also be reproduced in brass, bronze, or stainless steel. Each project, big or small, provides an economic opportunity for the fabricator and the foundry.

The key items to consider for reproduction are the quality of the sample item submitted as a pattern and the economic trade-off between the number of castings required and the amount of tooling investment needed to achieve the lowest overall cost. 

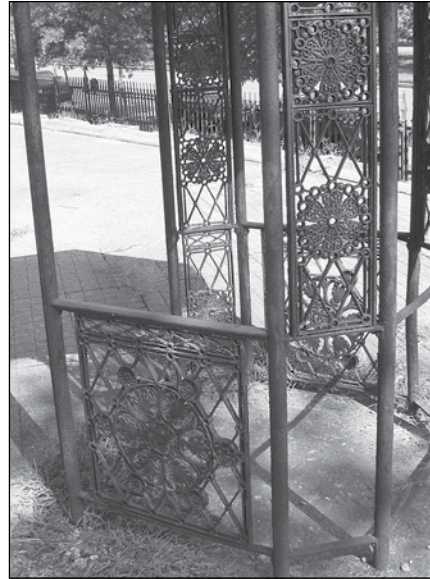

**Fig. 4:** The original, Civil War-era gazebo.



**Fig. 5:** The reproduced aluminum casting.

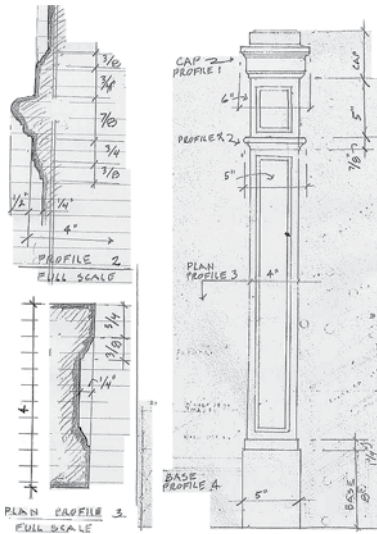

**Fig. 6:** Top left, the sketch for the courthouse post.

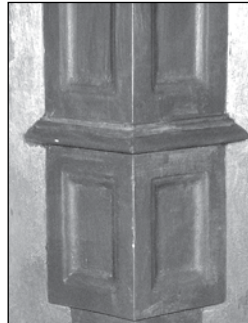

**Fig. 7:** Top right, the post pattern made from sketches.

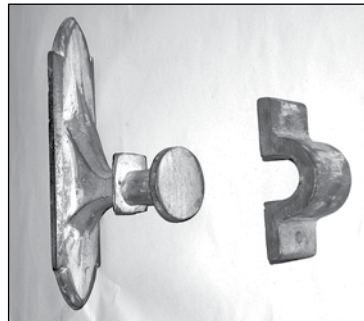

**Fig. 8:** Bottom, a two-piece handrail bracket.



Reprinted with permission.  
National Ornamental & Miscellaneous Metals Association  
© 2011. All rights reserved.





# TOP SECRET

## Three Things Your Foundry Won't Tell You About Saving Money and Time When Commissioning Custom Metal Castings

by Jon McGraw, Alloy Casting, Inc.

As a designer or architect, your goal is to create unique spaces that perfectly suit their purpose and leave a lasting impression on their inhabitants. One of the best ways to create a distinctive space is through the use of custom metal castings and designs. Unfortunately, the word "custom" and a general lack of knowledge about the design and casting process can strike fear in to the hearts of designers and architects, conjuring fears of price gouging and project delays while waiting for that just-right piece to be cast and delivered. In this paper, we'll expose some industry secrets and insider tips your foundry doesn't want you to know, but that will save you time and money while getting you the exceptional designs you dream of.



**TOP  
SECRET**

Three Things Your Foundry Won't Tell You  
About Saving Time and Money When  
Commissioning Custom Metal Castings

## 1.0 The Savings are in the Details

Have a great idea for a distinct ornamental piece? Quick, grab a napkin and sketch it out. A good foundry can take the most basic idea sketch, provide you with a quote, and turn that sketch into quality custom castings. But, many foundries don't have the time, resources, or desire to hand-hold clients through the entire custom design and casting process. This scenario can produce vague and inadequate communication which leads to costly delays.

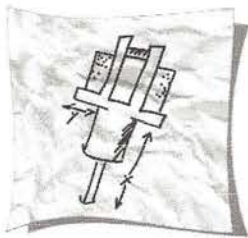

*A good foundry can turn even a simple sketch like the one on the left into a quality custom casting...*

*But a GREAT foundry will develop detailed design drawings like the one on the right that can be used to generate a comprehensive price quote.*

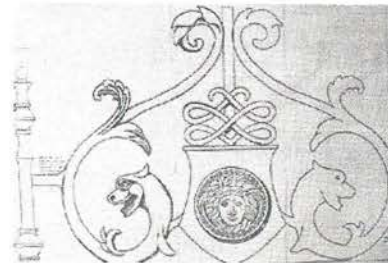

A great foundry will work with you to develop a detailed design drawing with the specifications and measurements necessary to develop a comprehensive price quote. They'll ask questions that gives the foundry a detailed understanding of the scope of the project and the application of the custom piece, and offer recommendations on the types of alloys that are ideal for the planned end use. Don't be offended if your foundry tells you that they're not right for the job, a project should be viable for both the producer and the end user. A great foundry will direct you to the right resources for what you need – whether it's another foundry, a machine shop, or a metal fabricator. Look for a foundry that is willing to consult with you from the earliest stages to help you get started and bring your project to life.

### TIP: What to Ask When Interviewing Foundries

What's the largest casting size I can get from your foundry?

What types of metals do you cast and which is right for my project?

Do you have a restriction on casting weight?

Do you have a minimum quantity or dollar amount per custom order?

Will the casting be paintable? (if applicable)

Will the casting hold a finish? (if applicable)

Do I need to prepare the casting in any way for final finishing?

Can your castings be welded?

Do you provide heat treatment? Is that included in the price quote? (if applicable)

Are there any charges in your quote other than pattern making/tooling and price per piece?

**TOP SECRET**

Three Things Your Foundry Won't Tell You About Saving Time and Money When Commissioning Custom Metal Castings

## 2.0 One Size – or Price – Does NOT Fit All

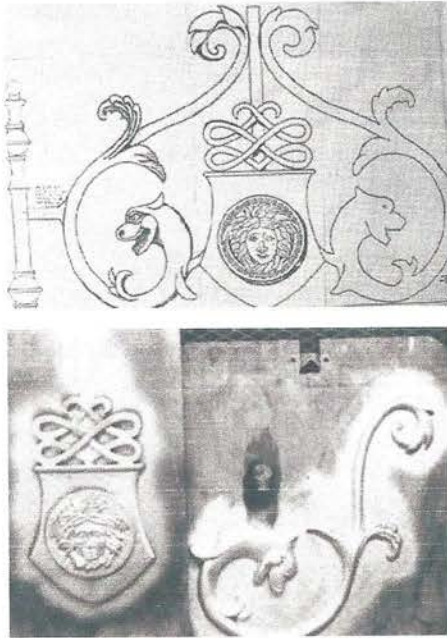

*Taking the time to specify details, cross sections, and dimensions with detailed drawings (top, above) can save you significantly in terms of time and money once you enter the pattern making portion of the project (bottom, above).*

Receiving a lump sum quote may seem like a good thing – until you need to increase or decrease your order and have no idea how much you're paying for each individual piece. Likewise, lumping together pattern making and tooling makes it difficult to comparison shop. Look for a foundry that will offer transparent, itemized pricing for pattern making, tooling, and per piece casting.

Sketches for decorative castings often lack dimensional detail. If details are vague or missing, it forces the woodcarver/patternmaker to provide his own artistic interpretation. The detailed design drawings mentioned earlier? Taking the time to specify details, cross sections, and dimensions can save you significantly once you enter the pattern making portion of the project. Pattern making consumes the majority of a typical custom project timeline and mistakes made here can be costly to correct. Once a pattern is passed through to the tooling stages, corrections not only increase costs significantly, but can also increase overall project time.

A great foundry will set up tooling in the most economical way for the customer. Tooling isn't a one-size fits all solution, if a client needs once piece, setting up tooling to make 10 pieces doesn't make sense. Likewise, tooling is (barring changes on a customer's part) a one-time fee.

Just like tooling is flexible based on project needs, a foundry should be flexible on using tooling from outside sources, and should be able to provide a price quote that reflects that. Your foundry may want input on outside tooling to determine how it will be used, how it's set up, sizing, and number of pieces. They're not being difficult; they're just ensuring that it will be the most practical and cost-effective method for delivering your finished product.

Finally, look for a foundry that can provide a per piece quote so that you, the customer, knows how pricing will change if quantity changes. This offers an enormous value over a single lump sum fee, which can make it extremely difficult for the end use to anticipate changes in cost in relation to changing project needs.

### Did You Know?

A typical timeline for custom work is 5-8 weeks, with the majority of that time being devoted to pattern work. In some cases, projects can be turned around in as little as 2-3 weeks.



**TOP  
SECRET**

Three Things Your Foundry Won't Tell You  
About Saving Time and Money When  
Commissioning Custom Metal Castings

### 3.0 Finished Should Mean *Finished*

Your foundry should provide a sample of the finished casting before initiating a production run. If the prototype sample does not meet the specifications of the original drawing, a great foundry will correct the error at no charge to you. But, if changes are made because of a redesign, those changes could result in increased tooling costs and time delays. Again, time spent in the initial planning and drawings stages will save you significant time and money later in the project.

Once you've approved your sample piece, it's time for the final production run. Look for a foundry that will provide finished, cleaned castings that don't require clean up on your end. When you receive your castings, they should be ready for their final application – whether it's painting or welding.

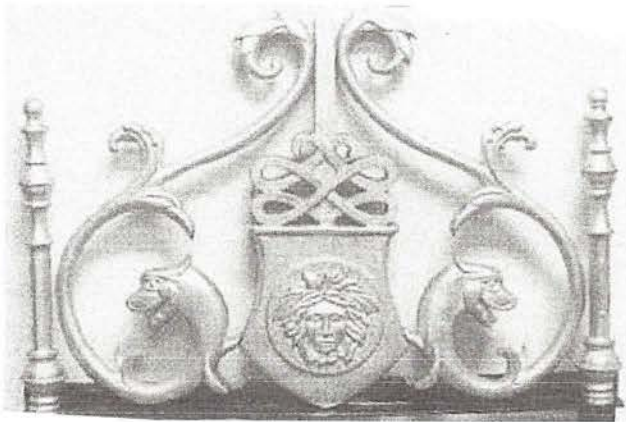

*The time and effort spent early in a custom project pays off when the final product is exactly what you had envisioned.*

Imagine an original space filled with original details – all designed by you. You now have the basic knowledge you need to work with a great foundry in commissioning the distinctive pieces that will inspire the end users of your spaces and let you leave your mark in a truly unique way.



#### About the Author:

Jon McGraw is the owner/operator of Alloy Casting, located in Mesquite, TX. Jon has worked with architects, designers, and fabricators for the past 32 years providing custom metal castings for every type of application. With a degree in metallurgical engineering from Case Western Reserve, an MBA from Stanford University and a professional resume that includes Reynolds Aluminum, Trane Corporation and New Jersey Steel, Jon is an expert in the foundry industry. His depth of knowledge ranges from the structural properties of metals through to best foundry industry practice.

#### TIP:

**What do you need to know if you provide your own pattern?**

There can be no undercuts.

Ensure that you have proper drafts and angles.

Your pattern should be 2% bigger than final casting.

Wood, plastic, steel, aluminum, resin are all ideal materials.

Clay CANNOT be used for patterns.

#### TIP:

When doing restoration work, look for a foundry that can create tooling directly from a sample part off the job and eliminate the pattern making expense.



# Bamboo Designs



**BAMBOO LEAVES and BAMBOO STICKS**  
in Bendable Aluminum



**GATE WITH 1/2 and 3/4 DIA BAMBOO STICKS**



**TYPICAL BAMBOO DETAIL**



**No. 7373**

H: 3 7/8"  
W: 3 1/4"  
T: 3 1/4"  
Wt.: .3 lbs  
Double Face



						
<b>No. 7821</b>	<b>No. 7822</b>	<b>No. 7804</b>	<b>No. 7806</b>	<b>No. 7808</b>	<b>No. 7814</b>	<b>No. 7816</b>
H: 6 1/8" W: 1 1/8" T: 1/8" Wt.: .10 lbs Flat Back	H: 9 3/4" W: 1 3/4" T: 1/8" Wt.: .15 lbs Flat Back	1/2" RD H: 40" DIA: 1/2" Wt.: .9 lbs Double Face	3/4" RD W: 40" DIA: 3/4" Wt.: 2 lbs Double Face	1" RD W: 40" DIA: 1" Wt.: 3.2 lbs Double Face	1 1/2" RD W: 42" DIA: 2" Wt.: 6.5 lbs Double Face	2" RD W: 40" DIA: 2" Wt.: 12 lbs Double Face

**Call or Email for Your Copy of Our FREE Auto CAD Library  
Now with 500 Auto CAD Drawings**

Stock Items Typically Ship Within One Week

 *American Made - American Quality - American Deliveries*

Call or email us today to sign up for email notifications



**NEW**

## Large Designs for Gates and Fences

No. 3858 (top)  
No. 3848 (bottom)

48" PINEAPPLE (2 pc)  
H: 47 1/2"  
W: 25 1/2"  
T: 2"  
Wt.: 67 lbs  
Flat Back

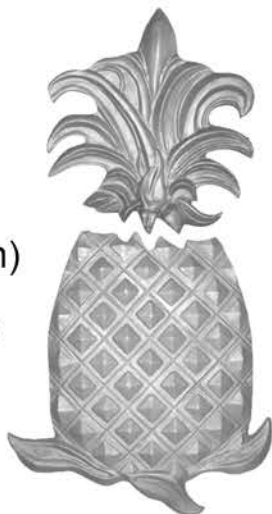

No. 9494  
FLAME ARMS  
H: 19 7/8"  
W: 4 3/8"  
T: 1"  
Wt.: 3 lbs  
Double Face

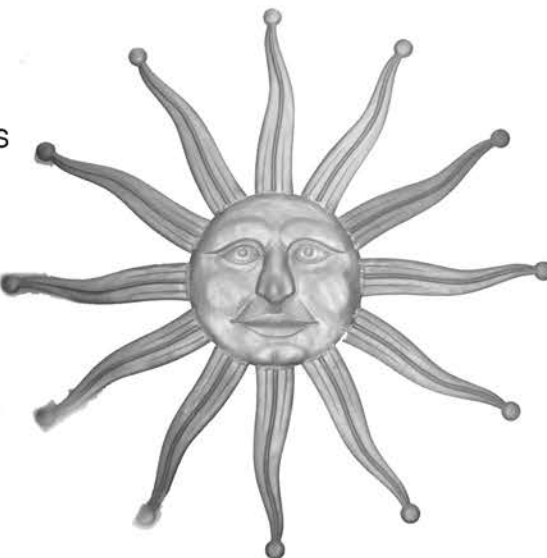

No. 9496  
SUN FACE  
19" diameter  
T: 2"  
Wt.: 23 lbs  
Flat Back

No. 3765  
SEA SHELL  
H: 20 5/8"  
W: 19"  
T: 3 1/2"  
Wt.: 13 lbs  
Hollow Back



No. 0064  
39" WIDE EAGLE  
H: 36 1/4"  
W: 39 1/2"  
T: 2"  
Wt.: 32.4 lbs  
Hollow Back



No. 3826  
LION'S HEAD  
H: 19 5/8"  
W: 17"  
T: 6"  
Wt.: 14 lbs  
Hollow Back



No. 3782  
PALM FROND  
H: 26 1/2"  
W: 27"  
T: 1/2"  
Wt.: 14 lbs  
Flat Back

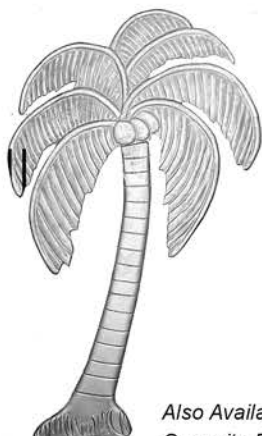

No. 2190  
WINGED ANGEL  
H: 29 1/2"  
W: 29 5/8"  
T: 3"  
Wt.: 30 lbs  
Flat Back



No. 0713  
CIRCLE STAR 36"  
36" diameter  
T: 4"  
Wt.: 135 lbs  
Flat Back



No. 3792  
PALM TRUNK  
H: 31 1/4"  
W: 13 1/2"  
T: 1/2"  
Wt.: 5 lbs  
Flat Back

No. 0714  
CIRCLE STAR 48"  
48" diameter  
T: 4"  
Wt.: 300 lbs  
Flat Back

*Also Available Leaning in  
Opposite Direction*

Stock Items Typically Ship Within One Week

 American Made - American Quality - American Deliveries

Call or email us today to sign up for email notifications



# New Post Designs



**Single Piece  
With  
Separate  
Top Selection**

No. 7172  
47" POST  
H: 47"  
W: 5"  
T: 1/2"  
Wt.: 18.1 lbs  
Double Face

## TOPS



No. 7171  
H: 6"  
W: 4 1/2"  
T: 3/4"  
Wt.: 1.8 lbs  
Double Face



No. 3530  
RD BALL CAP 3"  
RD BASE  
H: 6"  
W: 4" dia  
T: 1/4" wall  
Wt.: 1.8 lbs  
Double Face



No. 3531  
RD BALL CAP 3"  
W/COLLAR SHAPE  
H: 6 1/2"  
W: 4 3/4" dia  
T: 1/4" wall  
Wt.: 2.8 lbs  
Double Face

## STILL AVAILABLE AS A 4 PIECE POST



No. 9571  
2PC TOP  
H: 24 1/4"  
W: 9 1/4" dia  
T: 4 1/2" wall  
Wt.: 8 lbs  
Double Face



No. 9572  
2PC BOTTOM  
H: 23 1/2"  
W: 5 1/8" dia  
T: 2 1/2" wall  
Wt.: 5.4 lbs  
Double Face



All castings available in *Allo-Marine* Marine  
Grade corrosion resistant aluminum

Stock Items Typically Ship Within One Week

 *American Made - American Quality - American Deliveries*

Call or email us today to sign up for email notifications



# Roman Series



**No. 939**  
ROMAN PANEL  
W/PALM DF  
H: 29 1/8"  
W: 13 1/2" dia  
T: 3/4" wall  
Wt.: 8.4 lbs  
Double Face



**No. 1781**  
ROMAN W/DF  
PINEAPPLE  
H: 30 3/4"  
W: 13 1/2" dia  
T: 1 1/8" wall  
Wt.: 12.2 lbs  
Double Face



**No. 932**  
ROMAN PANEL  
WITH STAR  
H: 28 5/8"  
W: 14" dia  
T: 1 1/4" wall  
Wt.: 6.2 lbs  
Double Face



**No. 930**  
ROMAN PANEL  
14 X 28  
H: 29"  
W: 14" dia  
T: 3/4" wall  
Wt.: 4.5 lbs  
Double Face



**No. 934**  
ROMAN PANEL  
H: 29 1/2"  
W: 14 3/4" dia  
T: 5/8" wall  
Wt.: 4.6 lbs  
Double Face

**NEW**

No. 2737 37" Ht  
No. 2939 39" Ht



**NEW**

No. 2830 28 Pitch, 39" Ht  
No. 1736 35 Pitch, 35" Ht  
No. 2734 34 Pitch, 34" Ht



**NEW**

No. 927 27 Pitch, 23" Ht  
No. 2928 34 Pitch, 28" Ht



All castings available in  
*Allo-Marine* Marine  
Grade corrosion  
resistant aluminum

*Other Pitches / Other Designs Available*

Stock Items Typically Ship Within One Week  
 *American Made - American Quality - American Deliveries*  
 Call or email us today to sign up for email notifications



# New Designs

## NEW SCROLLS

No. 1804  
SCROLL  
H: 23 5/8"  
W: 5 3/8"  
T: 3/4"  
Wt.: 2 lbs  
Double Face



No. 1819  
SCROLL  
H: 28 3/4"  
W: 5"  
T: 3/4"  
Wt.: 2.3 lbs  
Double Face



No. 1808  
SINGLE FACE  
S SCROLL  
H: 22 1/8"  
W: 3 3/8"  
T: 3/8"  
Wt.: .7 lbs  
Single Face



No. 3672  
COMBO  
S AND C SCROLL  
H: 28 1/4"  
W: 9 1/4"  
T: 3/4"  
Wt.: 2.2 lbs  
Double Face



## ROUND BALL SLIP ON BALL CAPS



No. 9922  
2 1/2 ROUND BALL  
H: 5"  
W: 2 7/8"  
T: 5"  
Wt.: 1.9 lbs  
Double Face



No. 3530  
RD BALL CAP 3"  
RD BASE  
H: 6"  
W: 4" dia  
T: 1/4" wall  
Wt.: 1.8 lbs  
Double Face



No. 9429  
ROUND BALL  
CAP 4"  
H: 8 1/2"  
W: 5"  
T: 1/4"  
Wt.: 3.4 lbs  
Double Face

## SOLID HALF SPHERES

No. 1051 - 1" dia  
No. 1715 - 1.5" dia  
No. 1052 - 2" dia  
No. 1053 - 3" dia  
No. 1054 - 4" dia  
No. 1055 - 5" dia

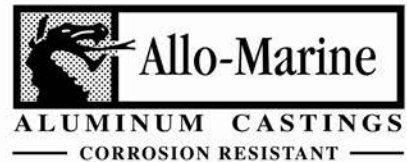

All castings available in *Allo-Marine* Marine  
Grade corrosion resistant aluminum

Stock Items Typically Ship Within One Week

🇺🇸 *American Made - American Quality - American Deliveries*

Call or email us today to sign up for email notifications



# Stars



**No. 932**  
H: 28 5/8"  
W: 14"  
T: 1 1/4"  
Wt.: 6.2 lbs  
Double Face

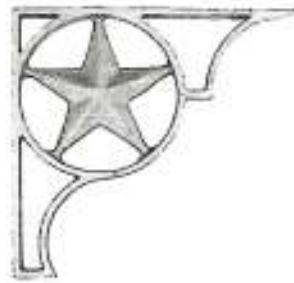

**No. 9125**  
H: 10 1/8"  
W: 10 3/4"  
T: 3/4"  
Wt.: 1.5 lbs  
Double Face



**No. 2291**  
H: 10 3/8"  
W: 10 3/8"  
T: 5/8"  
Wt.: 3.4 lbs  
Double Face  
*Beveled Star*



**No. 2292**  
H: 10 3/8"  
W: 10 3/8"  
T: 5/8"  
Wt.: 3.5 lbs  
Double Face  
*Ribbed Star*



**No. 8178**  
3 3/4" Dia  
T: 3/8"  
Wt.: .3 lbs  
Flat Back



**No. 8218**  
H: 4 1/2"  
W: 2 7/8"  
T: 1"  
Wt.: .3 lbs  
Double Face  
1/2" SQ Slip Over  
Circle 2 7/8" Dia



**No. 1769**  
4" Dia  
T: 1 3/8"  
Wt.: .4 lbs  
Double Face  
3/4" SQ Slip Over



**No. 8108**  
H: 7 7/8"  
W: 4 3/8"  
T: 3/8"  
Wt.: .1 lbs  
Flat Back



*Many Sizes Available!*

**No. 721**  
H: 2 7/8"  
W: 2 3/4"  
T: 1/4"  
Wt.: .1 lbs  
Flat Back



**No. 1448**  
3 2/1" Dia  
T: 2"  
Wt.: 1.5 lbs  
Double Face  
*Round and Square Hole*  
5/8" and 3/4" Size



Stock Items Typically Ship Within One Week  
 American Made - American Quality - American Deliveries  
 Call or email us today to sign up for email notifications





# Alloy Casting

T 174

MAILBOX SIGN BLADE PARTS

P

**#9820**  
 stub 1 1/2 h x 2 1/2 OD  
 1 3/8 ID  
 Double Face  
 6 H  
 6 W  
 2 T  
 1.6 lb

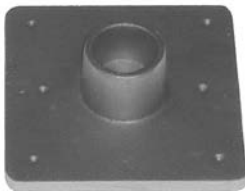

**#9825**  
 stub 1 1/2 h x 2 5/8 OD  
 1 7/8 ID  
 Double Face  
 6 H  
 6 W  
 2 T  
 1.8 lb

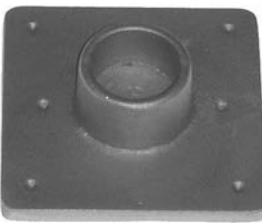

**#9821**  
 Double Face  
 19 H  
 6 1/8 W  
 3/8 T  
 4 lb



**#9828**  
 Double Face  
 13 1/2 H  
 4 W  
 3 1/2 T  
 2.1 lb



**#2770**  
 #2770 bracket for 8" height sign face opening sign  
 8 1/2 wide x flexible length  
 Pole boot rests around 3" DIA pole  
 Opening for slip in sign  
 Single Face  
 26 1/2 L  
 2 1/4 DIA  
 2.6 lb



**#2780**  
 for 8 wide sign blade  
 Length varies  
 26 1/2 H  
 2 1/4 W  
 2 1/4 T  
 2.6 lb

**EXPLODED VIEW of SIGN SLOT #2751**  
 1 W  
 1 T  
 variable length and weight

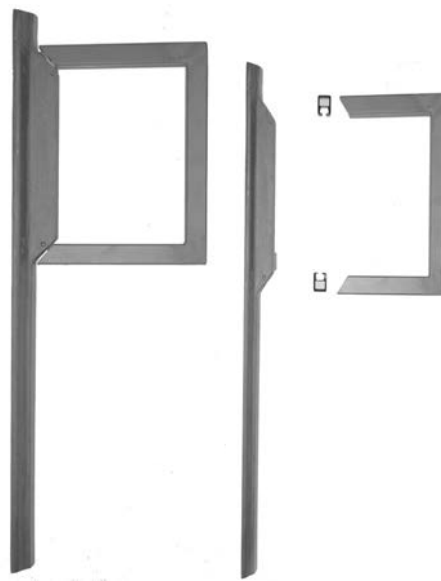





# Alloy Casting

T 87

MAIL BOX  
SIGN BLADES  
Page 1

**#9033**  
Sign Surface 8 X 2 ¼  
Double Face  
3 ¾ H  
16 W  
¾ T  
1 LB



**#2034**  
Double Face  
3 H  
14 ⅝ W  
½ T  
1.1 lb



**#2083**  
Sign Surface 12 x 4  
Double Face  
12 H  
15 7/8 W  
1 5/8 T  
5.7 lb

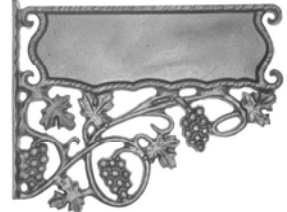

**#2084**  
Sign Surface 12 x 4  
Double Face  
13 H  
15 7/8 W  
1 5/8 T  
5.3 lb



**#4439**  
Sign Surface 13 x 8  
Double Face  
11 ½ H  
16 ¼ W  
2 T  
2.9 lb

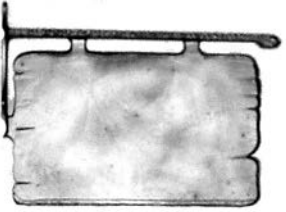

**#3088**  
Sign Surface 18x6  
Double Face  
12 H  
19 ¾ W  
1 ½ T  
3.9 lb



**#1088**  
Sign Surface 13 x 7  
Double Face  
10 H  
16 ½ W  
1 ¾ T  
2.6 lb

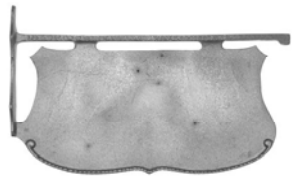

**#2088**  
Sign Surface 12 x 4  
Double Face  
12 ½ H  
16 W  
1 ⅝ T  
4.5 lb

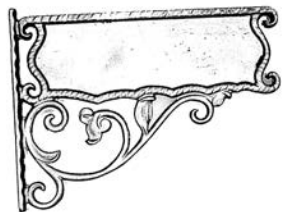

**#2093**  
Sign Surface 12 x 4  
Double Face  
12 H  
15 7/8 W  
1 5/8 T  
6.4 lb



**#2091**  
Sign Surface 12 x 4  
Double Face  
12 H  
15 7/8 W  
1 5/8 T  
5.4 lb

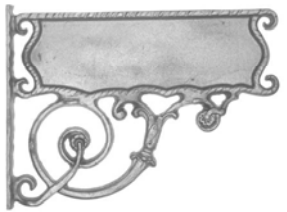

**#2094**  
Sign Surface 12 x 4  
Double Face  
13 7/8 H  
15 7/8 W  
1 5/8 T  
5.7 lb

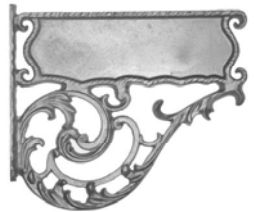

**#9623**  
Double Face  
8 H  
7 ¾ W  
¾ T  
1.3 lb

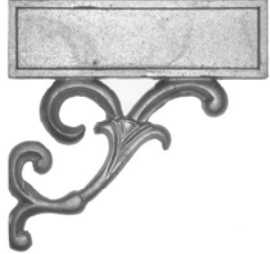



# Alloy Casting

T 89

MAIL BOX  
SIGN BLADES  
page 3

**#9368**  
Double Face  
4 7/8 H  
13 3/4 W  
5/8 T  
2.1 lb



**#9948**  
Double Face  
7 7/8 H  
34 1/2 W  
1 T  
9.8 lb



**#9947**  
Double Face  
7 7/8 H  
10 1/4 W  
1 T  
3.3 lb

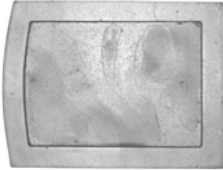

**#9687**  
Double Face  
9 1/2 H  
29 7/8 W  
1 1/8 T  
6.4 lb

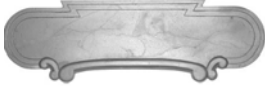

**#9355**  
Double Face  
4 H  
14 1/2 W  
3/4 T  
1.8 lb

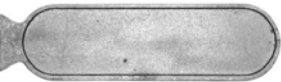

**#9779**  
Double Face  
3 1/8 H  
11 3/4 W  
1 1/4 T  
1.2 lb

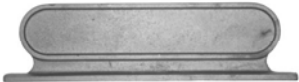

**#9949**  
Double Face  
9 1/4 H  
36 3/8 W  
1 T  
13.2 lb



**#9851**  
Double Face  
4 H  
9 7/8 W  
3/4 T  
1.5 lb

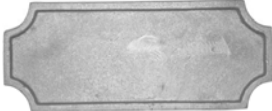

**#9039**  
Double Face  
7 7/8 H  
36 1/4 W  
1 1/2 T  
17.1 lb



**#9037**  
Double Face  
38 1/4 L  
7 W  
1 T  
7 lb



**#9036**  
Double Face  
38 L  
7 1/2 W  
1 3/8 T  
12.2 lb



**#2181**  
Double Face  
8 1/8 H  
36 W  
3/4 T  
7.6 lb





# Alloy Casting

T 123  
SIGN BLADES  
page 4

#9906  
Double Face  
5 <sup>3</sup>/<sub>4</sub> H  
9 <sup>1</sup>/<sub>2</sub> W  
<sup>3</sup>/<sub>4</sub> T  
1.5 lb

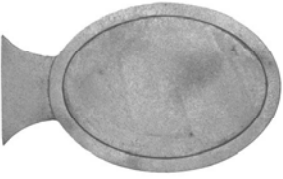

#9990  
Double Face  
5 <sup>5</sup>/<sub>8</sub> H  
7 W  
<sup>3</sup>/<sub>4</sub> T  
1 lb

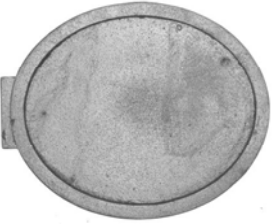

#9960  
Double Face  
14 H  
28 W  
<sup>3</sup>/<sub>4</sub> T  
7. lb



#

#

#

#

#

#

#

#

#



# Alloy Casting

T 198

MAIL BOX PARTS SET

**#9780**  
**OCTAGONAL DOOR DESIGN**  
 Single Face  
 8 7/8 H  
 9 1/8 W  
 1 1/4 T  
 2.4 lb

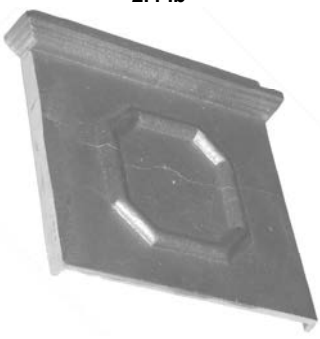

**#9783**  
**RECTANGULAR DOOR DESIGN**  
 Flat Back  
 8 5/8 H  
 9 1/8 W  
 1 1/4 T  
 4.3 lb



**##9793**  
**BACK**  
 Flat Back  
 8 3/4 H  
 7 1/8 W  
 1 T  
 1.8 lb

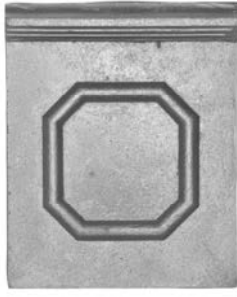

**##9792 LEFT SIDE**  
 Flat Back  
 18 7/8 W  
 8 3/4 H  
 1 T  
 4.1 Lb

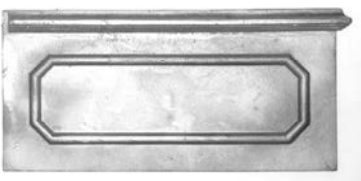

**#9791 RIGHT SIDE**  
 Flat Back  
 18 7/8 W  
 8 3/4 H  
 1 T  
 3.9 Lb



**##9790**  
**ROOF**  
 Single Face  
 9 3/8 H  
 20 1/4 W  
 2 1/8 T  
 6.1 lb



**##9778 2 piece set**  
**FLAG**  
**OVERALL DIMENSIONS**  
 5 1/8 H  
 1 1/8 W  
 1/2 T  
 .2 lb



**#2794**  
**FLOOR**  
 Double Face  
 18 H  
 7 1/8 W  
 5/8 T  
 3. lb

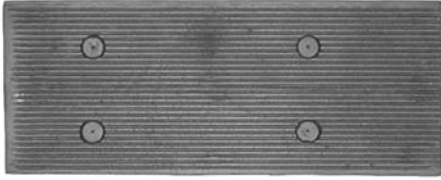



**NEW**

# Pineapples

No. 3858 (top)  
No. 3848 (bottom)

48" PINEAPPLE (2 pc)  
H: 47 1/2"  
W: 25 1/2"  
T: 2"  
Wt.: 67 lbs  
Flat Back

*Available in Left or Right  
Works Well Together  
Back-to-Back for Double Face*



## Additional Sizes

21" PINEAPPLE (1 PC)  
No. 3823 (Double Face)  
No. 3821 (Flat Back)

9" PINEAPPLE (1 PC)  
No. 1282 (Double Face)  
No. 1281 (Flat Back)

7" PINEAPPLE (1 PC)  
No. 3770 (Flat Back)



No. 9281  
H: 10 3/4"  
W: 10 3/4"  
T: 7/8"  
Wt.: 4.7 lbs  
Double Face



No. 9086  
H: 6"  
W: 6"  
T: 1"  
Wt.: 1.7 lbs  
Double Face



No. 1681  
H: 5 1/2"  
2 3/4" Dia  
Wt.: 1.7 lbs  
Double Face



No. 1781  
H: 31"  
W: 13 3/4"  
T: 1 1/4"  
Wt.: 14 lbs  
Double Face



# Alloy Casting

T 114

BIG TEX PANELS and INSERTS

**#2627**  
**Double Face**  
 31 H  
 25 3/8 W  
 7/8 T  
 13.8 lb



**#2640**  
**Double Face**  
 31 H  
 25 3/8 W  
 7/8 T  
 12 lb

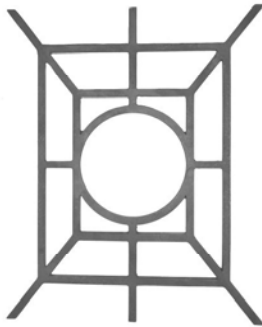

**#2635**  
**INSERT FOR 2640**  
**Double Face**  
 10 H  
 10 W  
 1 3/8 T  
 3.6 lb



**#2636**  
**INSERT FOR 2640**  
**Double Face**  
 8 3/4 H  
 7 1/4 W  
 1 T  
 2.2 lb

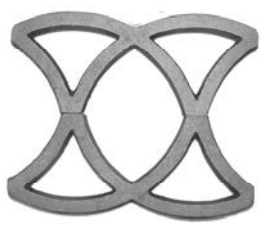

**#2639**  
**INSERT FOR 2640**  
**Double Face**  
 10 5/8 H  
 10 5/8 W  
 5/8 T  
 4. lb



**#2621**  
**INSERT FOR 2640**  
**Double Face**  
 9 3/4 H  
 9 5/8 W  
 1 1/4 T  
 3.2 lb



**#2622**  
**INSERT FOR 2640**  
**Double Face**  
 10 H  
 10 W  
 1 1/2 T  
 4.7 lb



**#2623**  
**INSERT FOR 2640**  
**Double Face**  
 10 H  
 10 1/2 W  
 1/2 T  
 1 lb



**#2625**  
**INSERT FOR 2640**  
**Double Face**  
 10 H  
 10 1/4 W  
 1 1/2 T  
 2.5 lb



**#2626**  
**INSERT FOR 2640**  
**Double Face**  
 10 1/2 H  
 10 1/2 W  
 1 1/2 T  
 6.5 lb

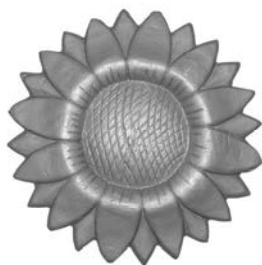

**#2628**  
**HORSE INSERT**  
**FOR #2640**  
  
**IN**  
**DEVELOPMENT**

**#2629**  
**INSERT FOR 2640**  
**Single Face**  
 10 1/2 H  
 10 1/2 W  
 1/2 T  
 1.1 lb

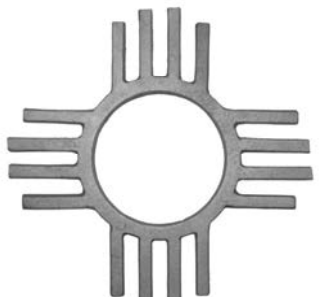

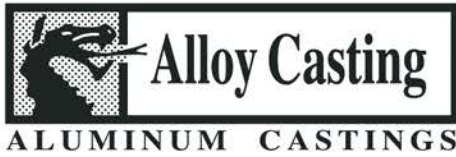

Mailing:  
PO Box 800008  
Balch Springs, TX 75180

Shipping:  
3900 S. Peachtree Road  
Balch Springs, TX 75180

Phone: 972.286.2368 | 800.527.1318 | Fax: 972.557.4727  
www.alloynet.com | jonalloy@aol.com

## *Quality Castings on Time*

### **Free Technical Information Included On:**

- Aluminum for Restorations
- Bendable Aluminum Castings
- Choosing the Right Alloy
- Custom Castings
- Custom-Designed Aluminum Castings
- Opera House Restoration
- Preparing to Power Coat
- Survey Says “Marine Grade”
- Understanding Custom Castings
- Wrought Aluminum Products and Their Designation

**FREE AUTO CAD LIBRARY  
NOW WITH 500 AUTO CAD DRAWINGS**

*ALL Castings Available in Marine Grade Aluminum*



Stock Items Typically Ship Within One Week  
🇺🇸 *American Made - American Quality - American Deliveries*

Call or email us today to sign up for email notifications



**NEW**

# Modern Greek Balusters

## Modern Versions of Greek Silhouettes

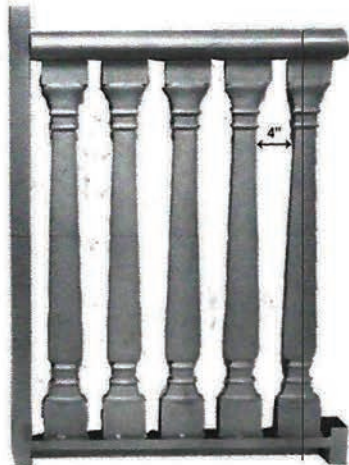

**No. 3255**

(Shown with 1.5" gap between caps)  
Minimum thickness 3/4" at belly  
Maximum thickness 1 3/16" at rings



**No. 3256**

(Shown with 1" gap between caps)  
Minimum thickness 3/4" at belly  
Maximum thickness 1 3/8" at rings

**Oval Shaped**

Top view



No. 3255  
H: 38"  
W: 5"

T: 3/4" top and bottom /  
1 3/16" at rings  
Wt: 8.4 lb  
Double Face

### BENEFITS

- Lower cost than stone/concrete
- Lower weight than stone/concrete
- Accepts powder coat colors
- Available for sea coast applications in marine grade aluminum
- Can be fabricated and installed like standard aluminum handrail
- Designed to meet 4" code



No. 3256  
H: 38"  
W: 6 1/4"

T: 3/4" top and bottom /  
1 3/8" at rings  
Wt: 14.6 lb  
Double Face

Stock Items Typically Ship Within One Week

 *American Made - American Quality - American Deliveries*

Call or email us today to sign up for email notifications



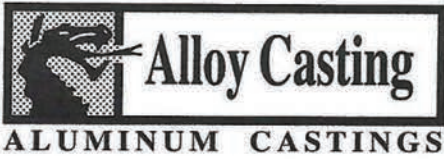

Mailing:  
PO Box 800008  
Balch Springs, TX 75180

Shipping:  
3900 S. Peachtree Road  
Balch Springs, TX 75180

Phone: 972.286.2368 | 800.527.1318 | Fax: 972.557.4727  
www.alloynet.com | jonalloy@aol.com



# Our Family of Ball Caps

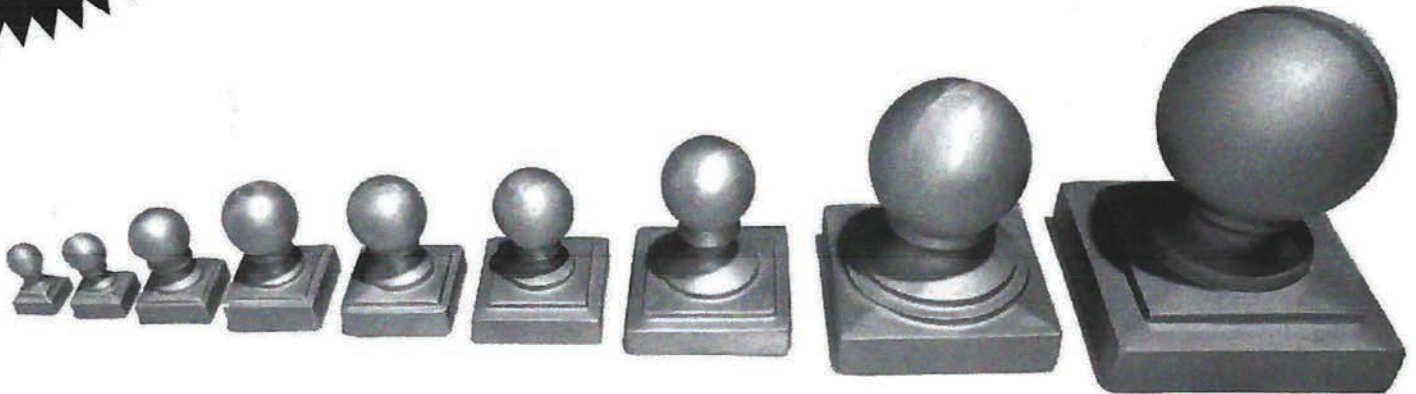

Smallest  
3/4" square

Largest  
6" square



**Meet the Newest  
Member of the Family**  
5" square with 4" diameter ball  
W: 5 1/2"  
L: 5 1/2"  
H: 7"  
Wt: 2.6 lbs.  
Hollow ball

*Many other ball caps, ball finials, ball collars, and balls available*



*Need a custom ball design?  
We can turn-key that project!  
Send a sketch and see what we can do*



All castings available in *Allo-Marine* Marine  
Grade corrosion resistant aluminum

Stock Items Typically Ship Within One Week  
American Made - American Quality - American Deliveries  
Call or email us today to sign up for email notifications







